



HAL
open science

ELECTRONIC LECTURE

Damien Prêle

► **To cite this version:**

Damien Prêle. ELECTRONIC LECTURE. Master. Electronic, University of Science and Technology of Hanoi, 2013, pp.81. cel-00843641v1

HAL Id: cel-00843641

<https://cel.hal.science/cel-00843641v1>

Submitted on 11 Jul 2013 (v1), last revised 12 Apr 2023 (v10)

HAL is a multi-disciplinary open access archive for the deposit and dissemination of scientific research documents, whether they are published or not. The documents may come from teaching and research institutions in France or abroad, or from public or private research centers.

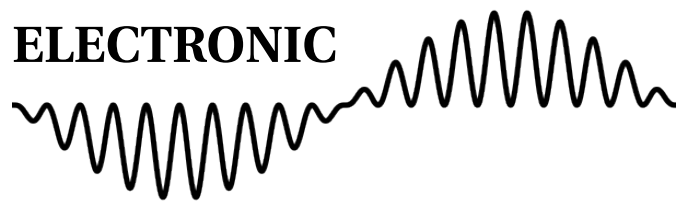

L'archive ouverte pluridisciplinaire **HAL**, est destinée au dépôt et à la diffusion de documents scientifiques de niveau recherche, publiés ou non, émanant des établissements d'enseignement et de recherche français ou étrangers, des laboratoires publics ou privés.

ELECTRONIC



UE 11.7 - Master of Space and Applications

Master co-habitated both by :

 **USTH** University of Science and Technology of Hanoi
 **PARIS DIDEROT** Paris Diderot University

DAMIEN PRÊLE

damien.prele@apc.univ-paris7.fr

2013

1	Filters	5
1.1	Introduction	5
1.2	Filter parameters	6
1.2.1	Voltage transfer function	6
1.2.2	S plane (Laplace domain)	7
1.2.3	Bode plot (Fourier domain)	8
1.3	Cascading filter stages	12
1.3.1	Polynomial equations	13
1.3.2	Filter Tables	18
1.3.3	The use of filter tables	19
1.3.4	Conversion from low-pass filter	21
1.4	Filter synthesys	23
1.4.1	Sallen-Key topology	23
1.5	Amplitude responses	28
1.5.1	Filter specifications	28
1.5.2	Amplitude response curves	28
1.6	Switched capacitor filters	32
1.6.1	Switched capacitor	33
1.6.2	Switched capacitor filters	35
2	DC/DC converters	38
2.1	Introduction	38
2.1.1	Advantages/Disadvantages	38
2.1.2	Applications	39
2.2	DC/DC converters	39
2.2.1	<i>Buck</i> converters	40
2.2.2	<i>Boost</i> converters	41
2.2.3	<i>Buck-boost</i> inverting converters	43
2.2.4	<i>Flyback</i> converters	43

2.3	Control	44
2.3.1	Feedback regulation	45
2.3.2	Voltage regulation	45
3	Phase Locked Loop	47
3.1	Introduction	47
3.2	Description	48
3.2.1	Phase detector/comparator	48
3.2.2	Voltage Control Oscillator - VCO	51
3.3	Frequency range	53
3.3.1	Lock range	53
3.3.2	Capture range	54
3.4	Frequency response	55
3.4.1	One pole loop filter	55
3.4.2	One pole - one zero loop filter	56
4	Modulation	58
4.1	Introduction	58
4.2	Amplitude modulation	60
4.2.1	Modulation index	62
4.3	Amplitude demodulation	63
4.3.1	Envelope demodulation	63
4.3.2	Product demodulation	64
A	Polynomials filter tables	72
B	CD4046 Data Sheet	74

THE present document is based on four lectures given for Master of Space and Application in University of Science and Technology of Hanoi on January and February 2013.

So, it consists of four parts. The first one is devoted to **filters**, while the second one deals with **DC/DC converter**, the third one discusses the **phase locked loop** and the last the **modulation**. For convenience of the readers the work is organized so that each part is self-contained and can be read independently. These four electronic systems are chosen because they are representative of critical elements encountered in spacecraft; whether for power supply or for data transmission.

In any case, this is also the opportunity to work on electronic systems requiring calculations of impedances, transfer functions or stability criteria. They are also good examples of uses of resistor, capacitor, inductor, transistor, logic gate ... as well as operational amplifiers or mixers.

Example isn't another way to teach, it is the only way to teach
Albert Einstein

Acknowledgements : Damien Prêle was teaching assistants in Paris-6 University for 4 years with professor Michel REDON. Topics of this lecture are inspired from M. Redon's lectures that were given at Paris-6 University for electronic masters. Therefore, this lecture is dedicated to the memory of professor Michel REDON who gave to the author his understanding of the electronic and helped him to start teaching it. Moreover, the author would like to express his gratitude to Miss Nguyen Phuong Mai and Mr. Pham Ngoc Dong for their help during the practical work which has followed this lecture in Hanoi.

1.1 Introduction

A filter performs a **frequency-dependent signal processing**. A filter is generally used to select a useful frequency band out from a wide band signal (example : to isolate station in radio receiver). It is also used to remove unwanted parasitic frequency band (example : rejection of the 50-60 Hz line frequency or DC blocking). Analogue to digital converter also require anti-aliasing low-pass filters.

The most common filters are low-pass, high-pass, band-pass and band-stop (or notch if the rejection band is narrow) filters :

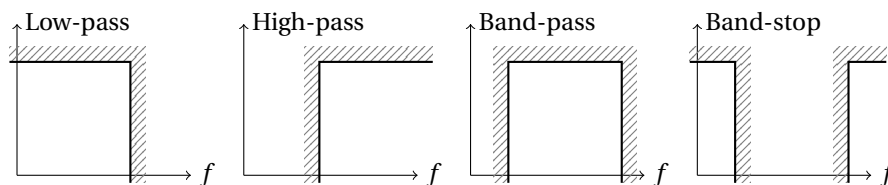

Figure 1.1: Transfer function of ideal filter : Fixed gain in the pass band and zero gain everywhere else ; transition at the cutoff frequency.

To do an electronic filter, **devices which have frequency-dependent electric parameter as L and C impedances** are necessary. The use of these reactive impedances* into a voltage bridge is the most common method to do a filtering ; this is called passive filtering. **Passive (R,L,C) filter is used at high frequencies** due to the low L and C values required. But, **at frequency lower than 1 MHz, it is more common to use**

*A reactive impedance is a purely imaginary impedance.

active filters made by an operational amplifier in addition to R and C with reasonable values. Furthermore, active filter parameters are less affected* by source and load impedances than passive one.

1.2 Filter parameters

1.2.1 Voltage transfer function

Passive low-pass filter example : a first order low-pass filter is made by R-C or L-R circuit as a voltage divider with frequency-dependent impedance. Capacitor impedance ($Z_C = \frac{1}{jC\omega}$) decrease at high frequency[†] while inductor impedance ($Z_L = jL\omega$) increases. Capacitor is then put across output voltage and inductor between input and output voltage (Fig. 1.2) to perform low pass filtering.

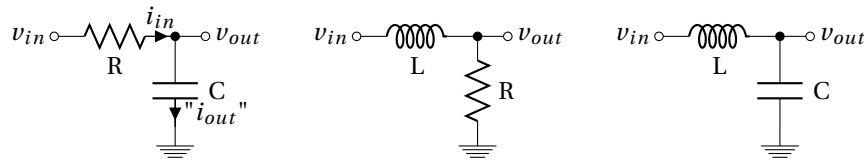

Figure 1.2: Passive low-pass filter : first order R-C, first order L-R and second order L-C.

Generalization : whatever impedances Z_x of the voltage bridge shown in figure 1.3, voltage transfer functions H are generalized as expression 1.1 by calculating the divider's voltage ratio using Kirchoff's voltage law[‡].

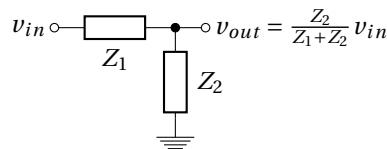

Figure 1.3: Impedance bridge voltage divider.

$$H(\omega) = \frac{v_{out}}{v_{in}} = \frac{Z_2}{Z_1 + Z_2} \quad (1.1)$$

*Active filter allows to separate the filter parameters with those matching impedance.

[†]angular frequency $\omega = 2\pi f$

[‡]The sum of the voltage sources in a closed loop is equivalent to the sum of the potential drops in that loop : $v_{in} = Z_1 \times \underbrace{\frac{v_{out}}{Z_2}}_{i_{in}=i_{out}} + v_{out}$

Voltage transfer functions of filters given in figure 1.2 are then expressed as :

$$H_{RC} = \frac{Z_C}{R + Z_C} = \frac{\frac{1}{jC\omega}}{R + \frac{1}{jC\omega}} \quad \Rightarrow \quad \boxed{H_{RC} = \frac{1}{1 + jRC\omega}} \quad (1.2)$$

$$H_{LR} = \frac{R}{R + Z_L} = \frac{R}{R + jL\omega} \quad \Rightarrow \quad \boxed{H_{LR} = \frac{1}{1 + j\frac{L}{R}\omega}} \quad (1.3)$$

$$H_{LC} = \frac{Z_C}{Z_L + Z_C} = \frac{\frac{1}{jC\omega}}{jL\omega + \frac{1}{jC\omega}} \quad \Rightarrow \quad \boxed{H_{LC} = \frac{1}{1 - LC\omega^2}} \quad (1.4)$$

☞ A filter can also be used to **convert** a current to a voltage or a voltage to a current in addition to a simple filtering*. Considering for example the first R-C low pass filter in figure 1.2. We can define **trans-impedance transfer function** $\frac{v_{out}}{i_{in}}$ and **the trans-admittance transfer function** $\frac{i_{out}}{v_{in}}$:

$$\frac{v_{out}}{i_{in}} = \frac{v_{out}}{i_{out}} = Z_C = \frac{1}{jC\omega} \quad \rightarrow \quad \text{Integrator} \quad (1.5)$$

$$\frac{i_{out}}{v_{in}} = \frac{1}{R + Z_C} = \frac{1}{R + \frac{1}{jC\omega}} = \frac{jC\omega}{1 + jRC\omega} \quad \rightarrow \quad \text{High-pass filter} \quad (1.6)$$

1.2.2 S plane (Laplace domain)

Due to the fact that L and C used in filter design has complex impedance, filter transfer function H can be represented as a function of a complex number s :

$$s = \sigma + j\omega \quad (1.7)$$

Frequency response and stability information can be revealed by plotting in a complex plane (s plane) roots values of $H(s)$ numerator (zero) and denominator (pole).

- **Poles** are values of s such that transfer function $|H| \rightarrow \infty$,
- **Zeros** are values of s such that transfer function $|H| = 0$.

Considering the band-pass filter of the figure 1.4, the transfer function $H_{LCR} = \frac{v_{out}}{v_{in}}$ is given by equation 1.8.

$$H_{LCR}(s) = \frac{R}{R + Ls + \frac{1}{Cs}} = \boxed{\frac{RCs}{1 + RCs + LCs^2}} \quad (1.8)$$

The order of the filter (Fig. 1.4) is given by the degree of the denominator of the expression 1.8. A **zero** corresponds the numerator equal to zero. A **pole** is given

*To filter a current, two impedances in parallel are require : current divider. In our example without load impedance $i_{in} = i_{out}$. Current transfer function $\frac{i_{out}}{i_{in}}$ is then always equal to 1.

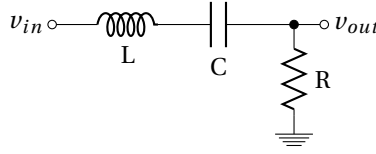

Figure 1.4: Passive band-pass LCR filter.

by the denominator equal to zero. Each pole provides a -20dB/decade slope of the transfer function ; each zero a + 20 dB/decade *. Zero and pole can be real or complex. When they are complex, they have a conjugate pair †.

Expression 1.8 is characterized by a zero at $\omega = 0$ and two conjugate poles obtained by nulling it's denominator (1.9).

$$0 = 1 + RCs + LCs^2 \xrightarrow{\text{discr.}} \Delta = (RC)^2 - 4LC \xrightarrow{\text{roots}} s_p = \frac{-RC \pm \sqrt{(RC)^2 - 4LC}}{2LC} \quad (1.9)$$

The two roots allow to obtain poles s_{p1} and s_{p2} given on 1.10.

$$s_p = \frac{-R}{2L} \pm j\sqrt{\frac{1}{LC} - \left(\frac{R}{2L}\right)^2} \quad (1.10)$$

The natural angular frequency ω_0 is the module of the pole :

$$\omega_0 = |s_{p1,2}| = \frac{1}{\sqrt{LC}} \quad (1.11)$$

In a s plane, pole and zero allow to locate where the magnitude of the transfer function is large (near pole), and where it is small (near zero). This provides us understanding of what the filter does at different frequencies and is used to study the stability. Figure 1.5 shows pole (✖) and zero (●) in a s plane.

A causal linear system is stable if real part of all poles is negative. On the s plane, this corresponds to a pole localization at the left side (Fig. 1.6).

1.2.3 Bode plot (Fourier domain)

The most common way to represent the transfer function of a filter is the Bode plot. Bode plot is usually a combination of the magnitude $|H|$ and the phase ϕ of the transfer function on a log frequency axis.

* $H[dB] = 20\log H[lin.]$ and a decade correspond to a variation by a factor of ten in frequency. A times 10 ordinate increasing on a decade (times 10 abscissa increasing) correspond to a 20dB/decade slope on a logarithmic scale or also 6dB/octave. A -20dB/decade then correspond to a transfer function decreasing by a factor of 10 on a decade

† each conjugate pair has the same real part, but imaginary parts equal in magnitude and opposite in signs

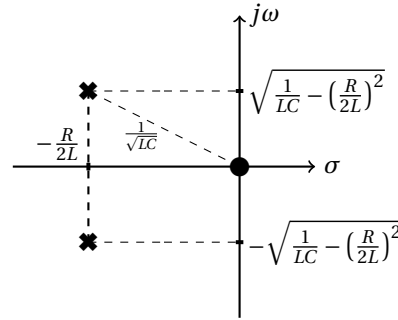

Figure 1.5: Pole (✖) and zero (●) representation of the RLC filter (Fig. 1.4) into the s plane.

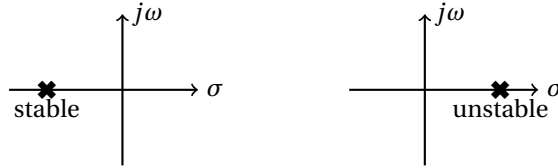

Figure 1.6: Stable if all poles are in the left hand s plane (*i.e.* have negative real parts).

Using the LCR band-pass filter (figure 1.4 example), the magnitude* and the phase[†] of the expression 1.8 (rewrite with unity numerator in 1.12) are respectively given by expressions 1.13 and 1.14. To do this, Fourier transform is used (harmonic regime) instead of Laplace transform : s is replaced by $j\omega$.

$$H_{LCR} = \frac{jRC\omega}{1 + jRC\omega - LC\omega^2} = \frac{1}{1 + j\left(\frac{L\omega}{R} - \frac{1}{RC\omega}\right)} \quad (1.12)$$

$$|H_{LCR}| = \frac{1}{\sqrt{1 + \left(\frac{L\omega}{R} - \frac{1}{RC\omega}\right)^2}} \quad (1.13)$$

$$\phi_{LCR} = \arg(H_{LCR}) = -\arctan\left(\frac{L\omega}{R} - \frac{1}{RC\omega}\right) \quad (1.14)$$

Numerical Application : $L = 1 \text{ mH}$, $C = 100 \text{ nF}$ and $R = 100 \Omega$

- The natural[‡] frequency $f_0 = \frac{1}{2\pi\sqrt{LC}} = \frac{10^5}{2\pi} \approx 16 \text{ kHz}$.

*Absolute value or module

[†]Argument

[‡]In the case of band-pass filter, *natural frequency* is also called *resonance frequency* or *center frequency*. This is the frequency at which the impedance of the circuit is purely resistive.

- The high pass-filter cutoff frequency $f_{c1} = \frac{R}{2\pi L} = f_0$.
- The low pass-filter cutoff frequency $f_{c2} = \frac{1}{2\pi RC} = f_0$.

The Bode diagram of this band-pass filter is plotted on figure 1.7.

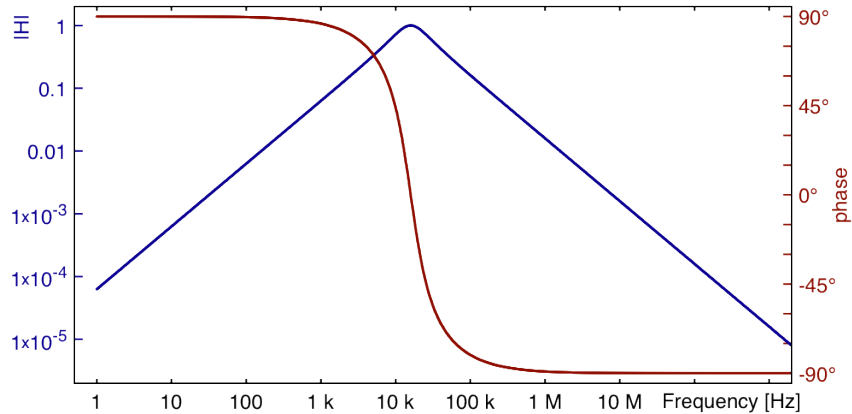

Figure 1.7: Bode plot of the LCR band-pass filter figure 1.4.

☞ Whatever the numerical application, $f_0 = \sqrt{f_{c1}f_{c2}}$ but f_0 , f_{c1} and f_{c2} are not necessarily equal.

In this numerical application $f_0 = f_{c1} = f_{c2}$ (Fig 1.7). This correspond to a particular case where the quality factor $Q = \frac{1}{R} \sqrt{\frac{L}{C}} = \frac{1}{100} \sqrt{\frac{10^{-3}}{10^{-7}}} = 1$. For other numerical application (i.e. $Q \neq 1$), f_0 is different than f_{c1} and f_{c2} (Fig 1.8).

Quality factor Q

Quality factor Q is a dimensionless parameter which indicates how much is the sharpness of a multi-pole filter response around its cut-off (or center *) frequency. In the case of a band-pass filter, its expression 1.15 is the ratio of the center frequency to the -3 dB bandwidth (BW) and is given for series and parallel LCR circuit.

$$\begin{aligned}
 Q &= \frac{f_0}{BW} \Big|_{\text{band-pass filter}} \\
 &= \frac{1}{R} \sqrt{\frac{L}{C}} \Big|_{\text{series LCR}} \\
 &= R \sqrt{\frac{C}{L}} \Big|_{\text{parallel LCR}}
 \end{aligned} \tag{1.15}$$

*for a band-pass filter

Quality factor is directly proportional to the **selectivity** of a band-pass filter (Fig. 1.8) :

- $Q < \frac{1}{2}$ → damped and wide band filter
- $Q > \frac{1}{2}$ → resonant and narrow band filter

We can again rewrite expressions 1.12 by using now natural frequency f_0 and quality factor Q :

$$H_{LCR} = \frac{jRC\omega}{1 + jRC\omega - LC\omega^2} = \frac{j\frac{1}{Q}\frac{\omega}{\omega_0}}{1 + j\frac{1}{Q}\frac{\omega}{\omega_0} - \frac{\omega^2}{\omega_0^2}} = \frac{j\frac{1}{Q}\frac{f}{f_0}}{1 + j\frac{1}{Q}\frac{f}{f_0} - \frac{f^2}{f_0^2}} = \frac{1}{1 + jQ\left(\frac{f}{f_0} - \frac{f_0}{f}\right)} \quad (1.16)$$

with $RC = \frac{1}{Q}\frac{1}{\omega_0}$, $Q = \frac{1}{R}\sqrt{\frac{L}{C}}$, $\omega_0 = 2\pi f_0 = \frac{1}{\sqrt{LC}}$ and $\omega = 2\pi f$.

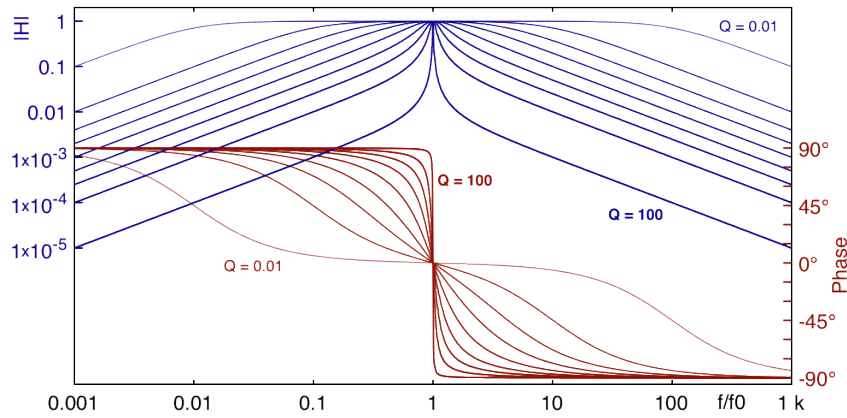

Figure 1.8: Bode plot of a band-pass filter - $Q = 0.01 ; 0.1 ; 0.25 ; 0.5 ; 1 ; 2 ; 4 ; 10 ; 100$ (i.e. $\zeta = 50 ; 5 ; 2 ; 1 ; 0.5 ; 0.25 ; 0.125 ; 0.05 ; 0.005$).

Damping factor ζ

Damping factor ζ is generally used in the case of low and high-pass filter (Low Q) when Q is used in the case of narrow band-pass filter, resonator and oscillator (High Q).

$$\zeta = \frac{1}{2Q} \quad (1.17)$$

The more damping the filter has, the flatter is its response and likewise, the less damping the filter has, the sharper is its response :

- $\zeta < 1$ → steep cutoff

- $\zeta = 1 \rightarrow$ critical damping
- $\zeta > 1 \rightarrow$ slow cutoff

Expression 1.12 may be rewritten using damping factor :

$$H_{LCR} = \frac{jRC\omega}{1 + jRC\omega - LC\omega^2} = \frac{j2\zeta \frac{\omega}{\omega_0}}{1 + j2\zeta \frac{\omega}{\omega_0} - \frac{\omega^2}{\omega_0^2}} \quad (1.18)$$

1.3 Cascading filter stages

Circuit analysis by applying Kirchoff's laws (as before) is usually only used for first and second order filter. For a higher order of filtering, network synthesis approach may be used. A polynomial equation expresses the filtering requirement. Each first and second order filter elements are then defined from continued-fraction expansion of the polynomial expression. In practice, to avoid saturation, highest Q stage is placed at the end of the network.

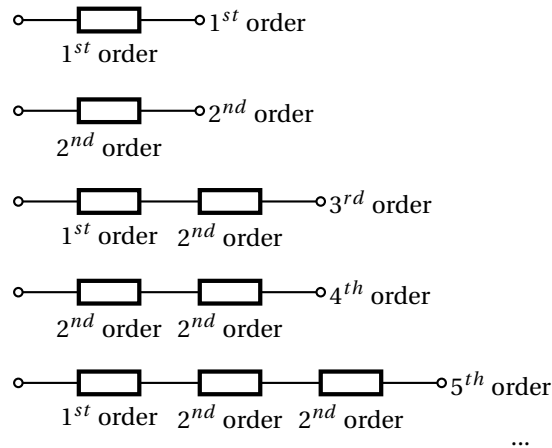

Figure 1.9: Cascading filter stages for higher-order filters.

It exists different type of polynomial equations from which the filter is mathematically derived. These type of filters are Butterworth, Bessel, Chebyshev, inverse Chebyshev, elliptic Cauer, Bessel, optimum Legendre, etc.

- **Butterworth** filter is known as the maximally-flat filter as regards to the flatness in the pass-band. The attenuation is simply -3 dB at the cutoff frequency; above, the slope is -20dB/dec per order (n).
- **Chebyshev** filter has a steeper rolloff* just after the cutoff frequency but ripple in the pass-band. The cutoff frequency is defined as the frequency at which

*rolloff = transition from the pass band to the stop band.

the response falls below the ripple band *. For a given filter order, a steeper cutoff can be achieved by allowing more ripple in the pass-band (Chebyshev filter transient response shows overshoots).

- **Bessel** filter is characterized by linear phase response. A constant-group delay is obtained at the expense of pass-band flatness and steep rolloff. The attenuation is -3 dB at the cutoff frequency.
- **elliptic Cauet** (non-polynomials) filter has a very fast transition between the passband and the stop-band. But it has ripple behavior in both the passband and the stop-band (not studied after).
- **inverse Chebychev - Type II** filter is not as steep rolloff than Chebychev but it has no ripple in the passband but in the stop band (not studied after).
- **optimum Legendre** filter is a tradeoff between moderate rolloff of the Butterworth filter and ripple in the pass-band of the Chebyshev filter. Legendre filter exhibits the maximum possible rolloff consistent with monotonic magnitude response in the pass band.

1.3.1 Polynomial equations

Filters are syntheses by using a H_0 DC gain and a polynomial equations P_n , with n the order of the equation, and then, of the filter. The transfer function of a synthesized low pass filter is $H(s) = \frac{H_0}{P_n\left(\frac{s}{\omega_c}\right)}$ with ω_c the cutoff angular frequency.

Butterworth polynomials

Butterworth polynomials are obtained by using expression 1.19 :

$$P_n(\omega) = B_n(\omega) = \sqrt{1 + \left(\frac{\omega}{\omega_c}\right)^{2n}} \quad (1.19)$$

The roots[†] of these polynomials occur on a circle of radius ω_c at equally spaced points in the s plane :

Poles of a $H(s)H(-s) = \frac{H_0^2}{1 + \left(\frac{-s^2}{\omega_c^2}\right)^n}$ low pass filter transfer function module are specified by :

$$\frac{-s^2}{\omega_c^2} = (-1)^{\frac{1}{n}} = e^{j\frac{(2x-1)\pi}{n}} \quad \text{with } x = 1, 2, 3, \dots, n \quad (1.20)$$

The denominator of the transfer function may be factorized as :

*The cutoff frequency of a Tchebyshev filter is not necessarily defined at - 3dB. f_c is the frequency value at which the filter transfer function is equal to $\frac{1}{\sqrt{1+\epsilon^2}}$ but continues to drop into the stop band. ϵ is the ripple factor. Chebyshev filter is currently given for a given ϵ ($20 \log \sqrt{1+\epsilon}$) in [dB].

[†]Roots of B_n are poles of the low-pass filter transfer function $H(s)$.

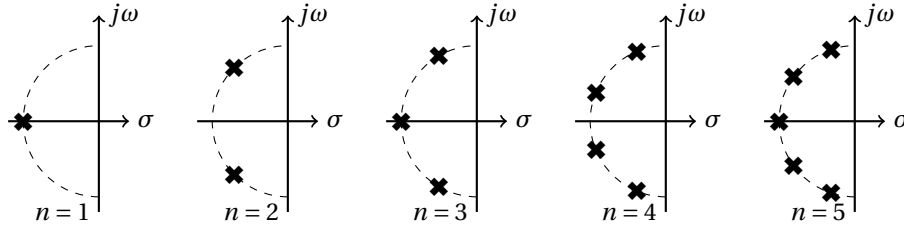

Figure 1.10: Pole locations of 1st, 2nd, 3rd, 4th and 5th order Butterworth filter.

$$H(s) = \frac{H_0}{\prod_{x=1}^n \frac{s-s_x}{\omega_c}} \quad (1.21)$$

The denominator of equation 1.21 is a Butterworth polynomial in s . Butterworth polynomials are usually expressed with real coefficients by multiplying conjugate poles*. The normalized† Butterworth polynomials has the form :

$$\begin{aligned} B_0 &= 1 \\ B_1 &= s + 1 \\ B_n &= \prod_{x=1}^{\frac{n}{2}} \left[s^2 - 2s \cos\left(\frac{2x+n-1}{2n}\pi\right) + 1 \right] \quad \text{n is even} \\ &= (s+1) \prod_{x=1}^{\frac{n-1}{2}} \left[s^2 - 2s \cos\left(\frac{2x+n-1}{2n}\pi\right) + 1 \right] \quad \text{n is odd} \end{aligned} \quad (1.22)$$

Chebyshev polynomials

Chebyshev polynomials are obtained by using expression 1.23 :

$$P_n = T_n = \begin{cases} \cos(n \arccos(\omega)) & |\omega| \leq 1 \\ \cosh(n \operatorname{arcosh}(\omega)) & |\omega| \geq 1 \end{cases} \quad (1.23)$$

where the hyperbolic cosine function $\cosh(x) = \cos(jx) = \frac{e^x + e^{-x}}{2}$. From the two first values $T_0 = 1$ and $T_1 = \omega$, Chebyshev polynomials $T_n(\omega)$ could be recursively obtained by using expression 1.24 :

*for example s_1 and s_n are complex conjugates

†normalized : $\omega_c = 1$ and $H_0 = 1$

$$\begin{aligned}
T_0 &= 1 \\
T_1 &= \omega \\
T_n &= 2\omega T_{n-1} - T_{n-2} \begin{cases} T_2 = 2\omega^2 - 1 \\ T_3 = 4\omega^3 - 3\omega \\ T_4 = 8\omega^4 - 8\omega^2 + 1 \\ \dots \end{cases} \quad (1.24)
\end{aligned}$$

Chebyshev low-pass filter frequency response is generally obtained by using a slightly more complex expression than for a Butterworth one :

$$|H(s)| = \frac{H'_0}{\sqrt{1 + \epsilon^2 T_n^2\left(\frac{\omega}{\omega_c}\right)}} \quad (1.25)$$

where ϵ is the ripple factor *. Even if $H'_0 = 1$, magnitude of a Chebyshev low-pass filter is not necessarily equal to 1 at low frequency ($\omega = 0$). Gain will alternate between maxima at 1 and minima at $\frac{1}{\sqrt{1+\epsilon^2}}$.

$$T_n\left(\frac{\omega}{\omega_c} = 0\right) = \begin{cases} \pm 1 & n \text{ is even} \\ 0 & n \text{ is odd} \end{cases} \Rightarrow H\left(\frac{\omega}{\omega_c} = 0\right) = \begin{cases} \frac{1}{\sqrt{1+\epsilon^2}} & n \text{ is even} \\ 1 & n \text{ is odd} \end{cases} \quad (1.26)$$

At the cutoff angular frequency ω_c , the gain is also equal to $\frac{1}{\sqrt{1+\epsilon^2}}$ (but $\forall n$) and, as the frequency increases, it drops into the stop band.

$$T_n\left(\frac{\omega}{\omega_c} = 1\right) = \pm 1 \quad \forall n \Rightarrow H\left(\frac{\omega}{\omega_c} = 1\right) = \pm \frac{1}{\sqrt{1+\epsilon^2}} \quad \forall n \quad (1.27)$$

Finally, conjugate poles s_x (equation 1.28 †) of expression 1.25 are obtained by solving equation $0 = 1 + \epsilon^2 T_n^2$:

$$s_x = \sin\left(\frac{2x-1}{n} \frac{1}{2\pi}\right) \sinh\left(\frac{1}{n} \operatorname{arcsinh} \frac{1}{\epsilon}\right) + j \cos\left(\frac{2x-1}{n} \frac{1}{2\pi}\right) \cosh\left(\frac{1}{n} \operatorname{arcsinh} \frac{1}{\epsilon}\right) \quad (1.28)$$

Using poles, transfer function of a Chebyshev low-pass filter is rewritten as equation 1.25 :

$$H(s) = \begin{cases} \frac{1}{\sqrt{1+\epsilon^2}} \prod_{x=1}^n \frac{s-s_x}{\omega_c} & n \text{ is even} \\ \frac{1}{\prod_{x=1}^n \frac{s-s_x}{\omega_c}} & n \text{ is odd} \end{cases} \quad (1.29)$$

* $\epsilon = 1$ for the other polynomials filter and is then not represented

† Poles are located on a centered ellipse in s plane ; with real axis of length $\sinh\left(\frac{1}{n} \operatorname{arcsinh} \frac{1}{\epsilon}\right)$ and imaginary axis of length $\cosh\left(\frac{1}{n} \operatorname{arcsinh} \frac{1}{\epsilon}\right)$.

Bessel polynomials

Bessel polynomials are obtained by using expression 1.30 :

$$P_n = \theta_n = \sum_{x=0}^n s^x \frac{(2n-x)!}{2^{n-x} x!(n-x)!} \begin{cases} \theta_1 = s + 1 \\ \theta_2 = s^2 + 3s + 3 \\ \theta_3 = s^3 + 6s^2 + 15s + 15 \\ \dots \end{cases} \quad (1.30)$$

Bessel low-pass filter frequency response is given by expression 1.31 and is also given for $n = 2$ (delay normalized second-order Bessel low-pass filter).

$$\frac{\theta_n(0)}{\theta_n\left(\frac{s}{\omega_c}\right)} \underset{n=2}{\implies} \frac{3}{\left(\frac{s}{\omega_c}\right)^2 + 3\frac{s}{\omega_c} + 3} = \frac{1}{\frac{1}{3}\left(\frac{s}{\omega_c}\right)^2 + \frac{s}{\omega_c} + 1} \quad (1.31)$$

However, Bessel polynomials θ_n have been normalized to unit delay at $\frac{\omega}{\omega_c} = 0$ (delay normalized) and are not directly usable for classical cutoff frequency at -3 dB standard (frequency normalized).

To compare this polynomials to the other one, the table 1.1 gives BCF factors for converting Bessel filter parameters to 3 dB attenuation at $\frac{\omega}{\omega_c} = 1$. These factors were used in preparing the frequency normalized tables given on Appendix I.

n	BCF
2	1.3616
3	1.7557
4	2.1139
5	2.4274
6	2.7034
7	2.9517
8	3.1796
9	3.3917

Table 1.1: Bessel conversion factor

By using BCF factor and for $n = 2$ we finally see in expression 1.32 the frequency response of a second order Bessel low pass filter :

$$H_2 = \frac{1}{\frac{BCF^2}{3}\left(\frac{s}{\omega_c}\right)^2 + BCF\frac{s}{\omega_c} + 1} \approx \frac{1}{0.618\left(\frac{s}{\omega_c}\right)^2 + 1.3616\frac{s}{\omega_c} + 1} \quad (1.32)$$

Module and phase are deduced from the equation 1.32 :

$$|H_2| = \frac{1}{\sqrt{\left(1 - 0.618 \frac{\omega^2}{\omega_c^2}\right)^2 + \left(1.3616 \frac{\omega}{\omega_c}\right)^2}} \quad (1.33)$$

$$\phi = \arg(H_2) = -\arctan\left(\frac{1.3616 \frac{\omega}{\omega_c}}{1 - 0.618 \frac{\omega^2}{\omega_c^2}}\right)$$

Bessel filter is characterized by a linear phase response. Group delay could be studied by calculating :

$$\tau_g = -\frac{d\phi}{d\omega} \quad (1.34)$$

Legendre polynomials

From the two first values $P_0(x) = 1$ and $P_1(x) = x$, (as for Chebyshev) Legendre polynomials $P_n(\omega^2)$ could be recursively obtained by using expression 1.35 :

$$P_0(x) = 1$$

$$P_1(x) = x$$

$$P_{n+1}(x) = \frac{(2n+1)xP_n(x) - nP_{n-1}(x)}{n+1} \begin{cases} P_2(x) = \frac{3x^2}{2} - \frac{1}{2} \\ P_3(x) = \frac{5x^3}{2} - \frac{3x}{2} \\ P_4(x) = \frac{35x^4}{8} - \frac{30x^2}{8} + \frac{3}{8} \\ \dots \end{cases} \quad (1.35)$$

From these polynomials, Legendre low-pass filter (expression 1.36) also called optimal filter are not directly defined from P_n but from optimal polynomials $L_n(\omega^2)$ described on expressions 1.37.

$$H(\omega) = \frac{1}{\sqrt{1 + L_n(\omega^2)}} \quad (1.36)$$

$$L_n(\omega^2) = \begin{cases} \int_{-1}^{2\omega^2-1} \left(\sum_{i=0}^k a_i P_i(x)\right)^2 dx & n = 2k+1 \text{ is odd} \\ \int_{-1}^{2\omega^2-1} (x+1) \left(\sum_{i=0}^k a_i P_i(x)\right)^2 dx & n = 2k+2 \text{ is even} \end{cases}$$

$$\text{with } a_i \begin{cases} n \text{ is odd } \forall k & a_0 = \frac{a_1}{3} = \frac{a_2}{5} = \dots = \frac{a_i}{2i+1} = \frac{1}{\sqrt{2(k+1)}} \\ n \text{ is even } \begin{cases} k \text{ is odd} & \begin{cases} \frac{a_1}{3} = \frac{a_3}{7} = \frac{a_5}{11} = \dots = \frac{a_i}{2i+1} = \frac{1}{\sqrt{2(k+1)(k+2)}} \\ a_0 = a_2 = a_4 = \dots = a_i = 0 \end{cases} \\ k \text{ is even} & \begin{cases} a_0 = \frac{a_2}{5} = \frac{a_4}{9} = \dots = \frac{a_i}{2i+1} = \frac{1}{\sqrt{2(k+1)(k+2)}} \\ a_1 = a_3 = a_5 = \dots = a_{i-1} = 0 \end{cases} \end{cases} \end{cases} \quad (1.37)$$

Finally, optimal polynomials could be calculated :

$$\begin{aligned}
L_0(\omega^2) &= 1 \\
L_1(\omega^2) &= \omega^2 \\
L_2(\omega^2) &= \omega^4 \\
L_3(\omega^2) &= \omega^2 - 3\omega^4 + 3\omega^6 \\
L_4(\omega^2) &= 3\omega^4 - 8\omega^6 + 6\omega^8 \\
L_5(\omega^2) &= \omega^2 - 8\omega^8 + 28\omega^6 - 40\omega^8 + 20\omega^{10} \\
&\dots
\end{aligned} \tag{1.38}$$

Factorization of the overall attenuation function* $\sqrt{1 + L_n(\omega^2)}$ is given on Appendix I.

However, it is not so important[†] to know how found Butterworth, Chebyshev, Bessel or Legendre polynomials coefficients; but it is more useful to know how to use them to design efficient filters. This is why it exists a lot of filter tables to simplify circuit design based on the idea of cascading lower order stages to realize higher-order filters.

1.3.2 Filter Tables

Filter tables could give complex roots or normalized polynomials coefficients c_0, c_1, \dots, c_n with $P_n = c_n s^n + c_{n-1} s^{n-1} + \dots + c_1 s + c_0$. However, more currently filter tables show factorized polynomials or directly normalized cutoff frequency (Scaling Factor - SF) and quality factor (Q) of each of stages for the particular filter being designed.

Some tables are now given using a Butterworth low-pass filter example.

Roots table

Some filter tables give complex roots of polynomials. Table 1.2 shows roots of Butterworth polynomials (they are obtained by using equation 1.22).

This table is also an indication of pole locations (in s plane) of low-pass filter having Butterworth polynomials as a transfer function denominator.

Polynomials coefficients table

An other table, concerning polynomials, shows directly coefficients c_x of polynomials as shown in table 1.3 for Butterworth polynomials $P_n = B_n = \sum_{x=0}^n c_x s^x = c_n s^n + c_{n-1} s^{n-1} + \dots + c_1 s + c_0$.

However, polynomials are generally factored in terms of 1^{st} and 2^{nd} order polynomials ; particularly to build cascading 1^{st} and 2^{nd} order filters.

*Attenuation function = denominator of a low pass filter

[†]for a filter designer point of view

order n	σ	$j\omega$
1	-1	0
2	-0.7071	± 0.7071
3	-0.5	± 0.866
	-1	0
4	-0.3827	± 0.9239
	-0.9239	± 0.3827
5	-0.309	± 0.951
	-0.809	± 0.5878
	-1	0
6	-0.2588	± 0.9659
	-0.7071	± 0.7071
	-0.9659	± 0.2588

7	-0.2225	± 0.9749
	-0.6235	± 0.7818
	-0.901	± 0.4339
	-1	0
8	-0.1951	± 0.9808
	-0.5556	± 0.8315
	-0.8315	± 0.5556
	-0.9808	± 0.1951
9	-0.1736	± 0.9848
	-0.5	± 0.866
	-0.766	± 0.6428
	-0.9397	± 0.342
	-1	0

Table 1.2: Butterworth polynomials complex roots.

Factored polynomials table

To cascade 1^{st} and 2^{nd} order filters (filter synthesis), a more useful table give a **factored representation of polynomials** as the Butterworth quadratic factors in Table 1.4.

Cutoff frequencies and quality factor table

Finally, an other useful table for filter designer is table which give directly cutoff frequency and quality factor of each 2^{nd} order filter. Table 1.5 gives frequency scaling factor and quality factor of Butterworth lowpass filter. A first order stage is just defined by a normalized cutoff frequency (SF) without quality factor (Q). Scaling factor is the ratio between the cutoff frequency of the considering stage and the cutoff frequency of the overall cascaded filter. In the particular case of Butterworth filter, the frequency scaling factor (SF) is always equal to one*.

1.3.3 The use of filter tables

To build, for example, a **second order Butterworth low-pass filter** we need to do the transfer function $H(s) = \frac{H_0}{P_n\left(\frac{s}{\omega_c}\right)}$ where P_n is a second order Butterworth polynomials *i.e.* $P_n = B_2$.

Table 1.2 could be used to write $B_2 = \left(\frac{s}{\omega_c} - r_1\right)\left(\frac{s}{\omega_c} - r_1^*\right)$ with r_1 and r_1^* the two conjugate roots $-0.7071 \pm j0.7071$. The transfer function of the Butterworth lowpass filter could be expressed as equation 1.39.

*each 1^{st} and 2^{nd} order filter have the same cutoff frequency than the Butterworth cascading filter has at the end. This is not the case for other polynomials filter as Chebyshev for which SF is often different than 1.

n	c_0	c_1	c_2	c_3	c_4	c_5	c_6	c_7	c_8	c_9	c_{10}
1	1	1									
2	1	1.41	1								
3	1	2	2	1							
4	1	2.61	3.41	2.61	1						
5	1	3.24	5.24	5.24	3.24	1					
6	1	3.86	7.46	9.14	7.46	3.86	1				
7	1	4.49	10.1	14.59	14.59	10.1	4.49	1			
8	1	5.13	13.14	21.85	25.69	21.85	13.14	5.13	1		
9	1	5.76	16.58	31.16	41.99	41.99	31.16	16.58	5.76	1	
10	1	6.39	20.43	42.8	64.88	74.23	64.88	42.8	20.43	6.39	1

Table 1.3: Butterworth polynomials coefficients c_x . $P_n = B_n = \sum_{x=0}^n c_x s^x = c_n s^n + c_{n-1} s^{n-1} + \dots + c_1 s + c_0$.

n	$P_n = B_n$
1	$s + 1$
2	$s^2 + 1.4142s + 1$
3	$(s + 1)(s^2 + s + 1)$
4	$(s^2 + 0.7654s + 1)(s^2 + 1.8478s + 1)$
5	$(s + 1)(s^2 + 0.618s + 1)(s^2 + 1.618s + 1)$
6	$(s^2 + 0.5176s + 1)(s^2 + 1.4142s + 1)(s^2 + 1.9319s + 1)$
7	$(s + 1)(s^2 + 0.445s + 1)(s^2 + 1.247s + 1)(s^2 + 1.8019s + 1)$
8	$(s^2 + 0.3902s + 1)(s^2 + 1.1111s + 1)(s^2 + 1.6629s + 1)(s^2 + 1.9616s + 1)$
9	$(s + 1)(s^2 + 0.3473s + 1)(s^2 + s + 1)(s^2 + 1.5321s + 1)(s^2 + 1.8794s + 1)$
10	$(s^2 + 0.3129s + 1)(s^2 + 0.908s + 1)(s^2 + 1.4142s + 1)(s^2 + 1.782s + 1)(s^2 + 1.9754s + 1)$

Table 1.4: Butterworth polynomials quadratic factors.

$$H(s) = \frac{H_0}{B_2\left(\frac{s}{\omega_c}\right)} = \frac{H_0}{\left(\frac{s}{\omega_c} + 0.7071 - j0.7071\right)\left(\frac{s}{\omega_c} + 0.7071 + j0.7071\right)} \quad (1.39)$$

The denominator development of the expression 1.39 give a quadratic form (expression 1.40) which clearly shows Butterworth polynomial coefficients given on table 1.3 and quadratic factors of table 1.4. It is also clear that expression 1.40 is similar to a classical representation of a transfer function with quality factor where SF and Q are finally what we can directly obtain from the table 1.5.

order n	1 st stage		2 nd stage		3 rd stage		4 th stage		5 th stage	
	SF	Q	SF	Q	SF	Q	SF	Q	SF	Q
1	1									
2	1	0.7071								
3	1	1	1							
4	1	0.5412	1	1.3065						
5	1	0.618	1	1.6181	1					
6	1	0.5177	1	0.7071	1	1.9320				
7	1	0.5549	1	0.8019	1	2.2472	1			
8	1	0.5098	1	0.6013	1	0.8999	1	2.5628		
9	1	0.5321	1	0.6527	1	1	1	2.8802	1	
10	1	0.5062	1	0.5612	1	0.7071	1	1.1013	1	3.1969

Table 1.5: Butterworth normalized cutoff frequency (Scaling Factor - SF) and quality factor (Q) for each stages.

$$H(s) = \frac{H_0}{\left(\frac{s}{\omega_c}\right)^2 + 1.41\frac{s}{\omega_c} + 1} = \frac{H_0}{1 + j\frac{1}{Q}\frac{f}{SFf_c} - \frac{f^2}{SF^2f_c^2}} \quad \text{with} \quad \begin{cases} SF = 1 \\ Q = \frac{1}{1.41} = 0.7071 \end{cases} \quad (1.40)$$

Bode diagram of this low pass filter could be expressed as equation 1.41 and plotted as figure 1.11.

$$|H(\omega)| = \frac{1}{\sqrt{\left[1 - \left(\frac{\omega}{\omega_c}\right)^2\right]^2 + \left(1.41\frac{\omega}{\omega_c}\right)^2}} \quad \text{with} \quad H_0 = 1 \quad (1.41)$$

$$\phi(\omega) = \arg(H) = -\arctan \frac{1.41\frac{\omega}{\omega_c}}{1 - \left(\frac{\omega}{\omega_c}\right)^2}$$

1.3.4 Conversion from low-pass filter

Low-pass to high-pass filter Filter tables give polynomials for low and high-pass filter. To obtain a high pass filter, a first order low pass filter transfer function $\frac{H_0}{c_0 + c_1 s}$ becomes $\frac{H_\infty s}{c_1 + c_0 s}$; and a second order low pass filter transfer function $\frac{H_0}{c_0 + c_1 s + c_2 s^2}$ becomes $\frac{H_\infty s^2}{c_2 + c_1 s + c_0 s^2}$. Figure 1.12 shows low and high pass filter with H_0 and H_∞ *.

*in practice, there is always a frequency limitation which constitute a low pass filter, so that an ideal high pass filter never exists and $H_\infty \rightarrow 0$. So, in the case of real high pass filter, H_∞ signifies more the gain just after the cut-off frequency than that at infinity.

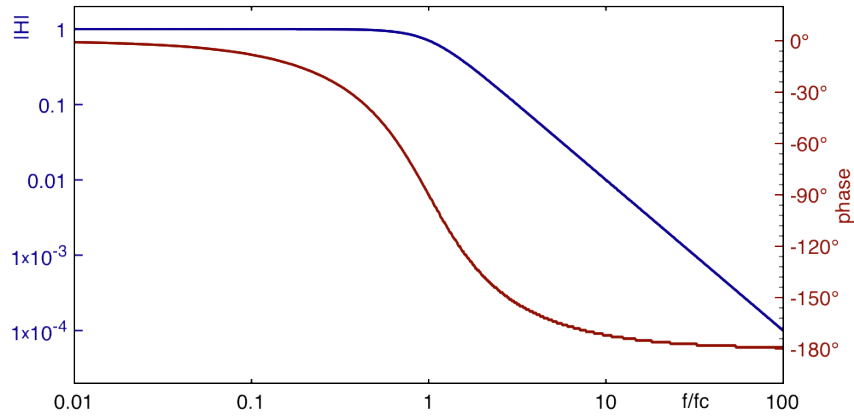
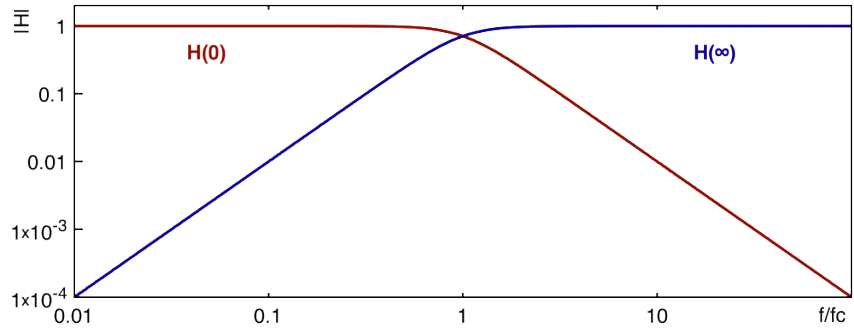

Figure 1.11: Bode plot of a second order Butterworth low pass filter.

$$\begin{aligned}
 H_{LP1} &= \frac{H_0}{c_0 + c_1 s} & \Rightarrow & H_{HP1} = \frac{H_\infty}{c_0 + c_1/s} \\
 H_{LP2} &= \frac{H_0}{c_0 + c_1 s + c_2 s^2} & \Rightarrow & H_{HP2} = \frac{H_\infty}{c_0 + c_1/s + c_2/s^2}
 \end{aligned}
 \tag{1.42}$$

Low to High pass filter conversion: $s \Rightarrow s^{-1}$

Figure 1.12: H_0 the low frequency gain of a low-pass filter and H_∞ the high frequency gain of a high-pass filter.

Band-pass filter For band-pass filter, it exists specific tables which give specific coefficients given for different bandwidth (BW). However, a low pass filter transfer

function could be converted in band-pass filter by replacing s by $\frac{f_0}{BW} (s + s^{-1})$; where $\frac{f_0}{BW}$ is equal to the quality factor Q .

$$\text{Low to Band-pass filter conversion: } s \Rightarrow Q (s + s^{-1})$$

Band-reject filter A low pass filter transfer function is converted in band-reject filter by replacing s by $\frac{1}{\frac{f_0}{BW} (s + s^{-1})}$.

$$\text{Low to Band-reject filter conversion: } s \Rightarrow Q^{-1} (s + s^{-1})^{-1}$$

Transposition A synthesis of different transpositions are reported in the table 1.6.

Filter type Conv.	Low-pass	High-pass	Band-pass	Band-reject
Normalized complex frequency	s	s^{-1}	$Q (s + s^{-1})$	$\frac{1}{Q} \frac{1}{s + s^{-1}}$
First order transfert function	$\frac{1}{C_0 + C_1 s}$	$\frac{1}{C_0 + C_1 / s}$	$\frac{1}{C_0 + C_1 Q (s + s^{-1})}$	$\frac{1}{C_0 + \frac{C_1}{Q (s + s^{-1})}}$
Second order transfert function	$\frac{1}{C_0 + C_1 s + C_2 s^2}$	$\frac{1}{C_0 + C_1 / s + C_2 / s^2}$		

Table 1.6: Filter normalized transposition.

The transfer function is obtained by using filter table after determination of type and order. The next step is to determine a circuit to implement these filters.

1.4 Filter synthesis

It exists different topologies of filter available for filter synthesis. The most often used topology for an active realization is Sallen-Key topology (Fig. 1.13).

1.4.1 Sallen-Key topology

Sallen-Key electronic circuit (Fig. 1.13) is used to implement second order active filter.

From Kirchhoff laws, transfer function of the generic Sallen-Key topology could be written as :

$$H_{SK} = \frac{H_0}{1 + \left[\frac{Z_1 + Z_2}{Z_4} + (1 - H_0) \frac{Z_1}{Z_3} \right] + \frac{Z_1 Z_2}{Z_3 Z_4}} \quad (1.43)$$

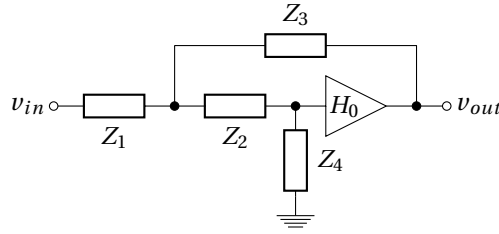

Figure 1.13: Sallen-Key generic topology.

Sallen-Key low-pass filter

A low-pass filter is easily obtained from this circuit. Figure 1.14 show a Sallen-Key low-pass filter.

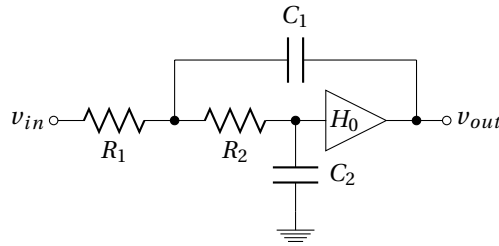

Figure 1.14: Sallen-Key low-pass filter.

The transfer function of this Sallen-Key low-pass filter is given by equation 1.44.

$$\begin{aligned}
 H_{SKLP} &= \frac{H_0}{1 + [(R_1 + R_2)C_2 + R_1C_1(1 - H_0)]s + R_1R_2C_1C_2s^2} \\
 &= \frac{H_0}{c_0 + c_1s + c_2s^2} \\
 &= \frac{H_0}{1 + j\frac{1}{Q}\frac{f}{SFf_c} - \frac{f^2}{SF^2f_c^2}} \quad \text{with} \quad \begin{cases} SFf_c = \frac{1}{2\pi\sqrt{R_1R_2C_1C_2}} \\ Q = \frac{\sqrt{R_1R_2C_1C_2}}{(R_1+R_2)C_2+R_1C_1(1-H_0)} \end{cases}
 \end{aligned} \tag{1.44}$$

This second order Sallen-Key filter can be used to realize one complex-pole pair in the transfer function of a low-pass cascading filter. Values of the Sallen-Key circuit could be chosen to correspond to a polynomial coefficients (as Butterworth, Chebyshev or Bessel).

Sallen-Key high-pass filter

To transform a low-pass filter to a high-pass filter, all resistors are replaced by capacitor and capacitors by resistors :

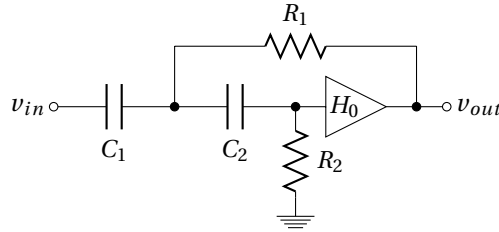

Figure 1.15: Sallen-Key high-pass filter.

The transfer function of this Sallen-Key high-pass filter is given by equation 1.45.

$$\begin{aligned}
 H_{SKHP} &= H_0 \frac{R_1 R_2 C_1 C_2 s^2}{1 + [R_1(C_1 + C_2) + R_2 C_2(1 - H_0)]s + R_1 R_2 C_1 C_2 s^2} \\
 &= \frac{H_0}{c_0 + \frac{c_1}{s} + \frac{c_2}{s^2}} = \frac{H_0 \frac{c_2}{c_0} s^2}{c_0 + \frac{c_1 c_2}{c_0} s + c_2 s^2} \\
 &= \frac{H_0 \frac{-f^2}{SF^2 f_c^2}}{1 + j \frac{1}{Q} \frac{f}{SF f_c} - \frac{f^2}{SF^2 f_c^2}} \quad \text{with} \quad \begin{cases} SF f_c = \frac{1}{2\pi \sqrt{R_1 R_2 C_1 C_2}} \\ Q = \frac{\sqrt{R_1 R_2 C_1 C_2}}{R_1(C_1 + C_2) + R_2 C_2(1 - H_0)} \end{cases}
 \end{aligned} \tag{1.45}$$

Sallen-Key band-pass filter

Band-pass filter could be obtained by placing in series a high and a low pass filter as illustrated in figure 1.16. Cut-off frequency of the low pass filter need to be higher than the high-pass one ; unless you want to make a resonant filter.

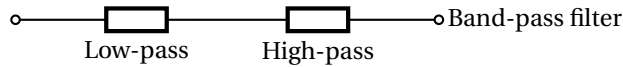

Figure 1.16: Cascading low and high pass filter for band-pass filtering.

A possible arrangement of generic Sallen-Key topology in band-pass configuration is given in figure 1.17.

But we can also found more complicated band-pass filter as figure 1.18 based on voltage-controlled voltage-source (VCVS) filter topology which gives the transfer function expressed in equation 1.46.

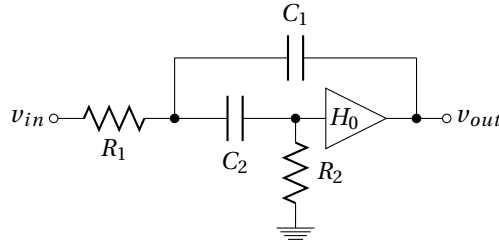

Figure 1.17: Sallen-Key band-pass filter.

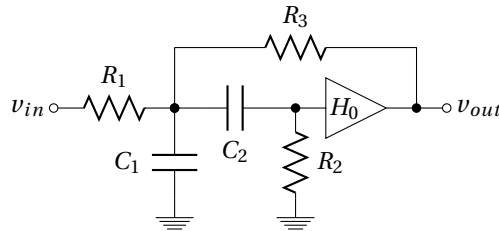

Figure 1.18: Voltage-controlled voltage-source (VCVS) filter topology band-pass filter.

$$\begin{aligned}
 H_{VCVS_{BP}} &= H_0 \frac{\frac{R_2 R_3 C_2}{R_1 + R_3} s}{1 + \frac{R_1 R_3 (C_1 + C_2) + R_2 R_3 C_2 + R_1 R_2 C_2 (1 - H_0)}{R_1 + R_3} s + \frac{R_1 R_2 R_3 C_1 C_2}{R_1 + R_3} s^2} \\
 &= \frac{H'_0 s}{c_0 + c_1 s + c_2 s^2} \quad \text{with} \quad H'_0 = H_0 \frac{R_2 R_3 C_2}{R_1 + R_3} \\
 &= \frac{H'_0 s}{1 + j \frac{1}{Q} \frac{f}{SF f_c} - \frac{f^2}{SF^2 f_c^2}} \quad \text{with} \quad \begin{cases} SF f_c = \frac{1}{2\pi} \sqrt{\frac{R_1 + R_3}{R_1 R_2 R_3 C_1 C_2}} \\ Q = \frac{\sqrt{(R_1 + R_3) R_1 R_2 R_3 C_1 C_2}}{R_1 R_3 (C_1 + C_2) + R_2 R_3 C_2 - R_1 R_2 C_2 (1 - H_0)} \end{cases} \quad (1.46)
 \end{aligned}$$

Sallen-Key band-reject filter

Unlike the band-pass filter, a notch filter can not be obtained by a series connection of low and high pass filters. But a summation of the output * of a low and a high pass filter could be a band-reject filter if cut-off frequency of the low pass filter is lower than the high-pass one. This correspond to paralleling high and low pass filter.

Band-reject filter could be obtained by placing in parallel a high and a low pass filter as illustrated in figure 1.19.

*In practice it is not possible to connect two outputs each other without taking some precautions.

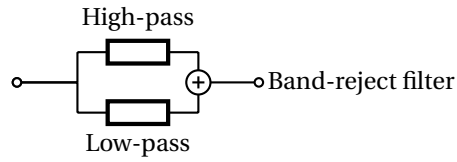

Figure 1.19: Paralleling low and high pass filter for band-pass filtering.

A band-reject filter is finally obtained by using circuit of figure 1.20.

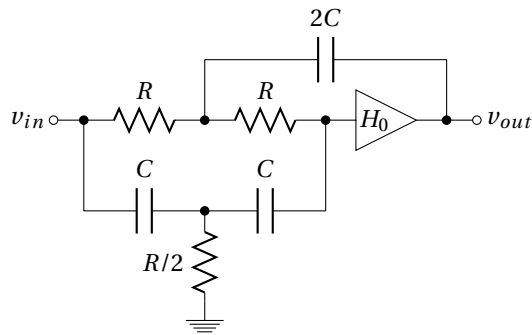

Figure 1.20: Sallen-Key band-reject filter.

Parameters of this simplified Sallen-Key band reject filter is given by expression 1.47.

$$SFf_c = \frac{1}{2\pi\sqrt{RC}} \quad (1.47)$$

$$Q = \frac{1}{4 - 2H_0}$$

1.5 Amplitude responses

1.5.1 Filter specifications

The more common filter specification is the **roll-off rate** which increases with the order *. It is 20dB/decade per pole for high and low pass filter (per pair of poles for band-pass filter). **Ripples** in pass-band and stop-band need to be also specified. Around a cutoff frequency, these specifications could be also defined by 5 transfer function requirements :

- maximum amplitude $|H|_{max}$ †
- pass-band cut-off frequency f_c
- maximum allowable attenuation in the band-pass A_{max} ‡
- frequency at which stop-band begins f_s
- minimum allowable attenuation in the stop-band A_{min}

Figure 1.21 lets appear these various parameters in the case of a low pass filter :

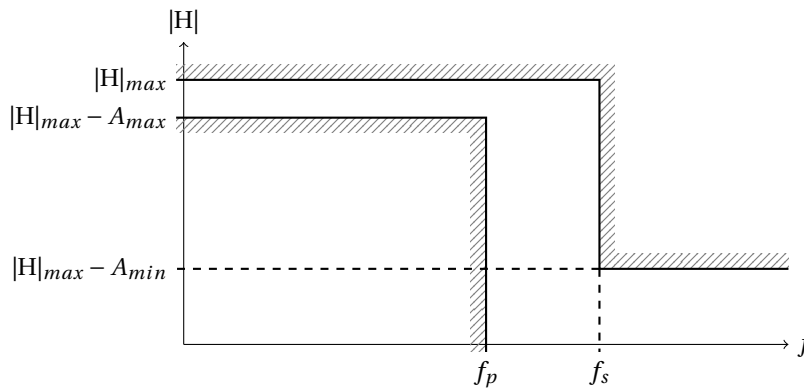

Figure 1.21: Filter amplitude response limits.

1.5.2 Amplitude response curves

Chebyshev filter has a steeper rolloff near the cutoff frequency when compared to Butterworth and Bessel filters. While, Bessel not exhibit a frequency dependance phase shift as Butterworth and Chebyshev filter. Butterworth is a good compromise

*The order of the filter is linked to the number of elements (first and second order filter) used in the network (Fig. 1.9).

† in the case of low-pass filter, $|H|_{max} = H_0$ the DC gain and H_∞ in the case of high-pass filter $|H|_{max}$, is generally equal to 1.

‡ $A_{max} = 3dB$ in the case of Butterworth or Bessel filter and $A_{max} = \frac{1}{\sqrt{1+\epsilon^2}}$ for Chebyshev filter.

as regards to the rolloff, while having a maximally-flat frequency response. Finally, Legendre filter has the steeper rolloff without ripple in the band pass. These kind of comparison between Butterworth, Chebyshev, Bessel and Legendre filter is outlined by figure 1.22 and tables 1.7 and 1.8.

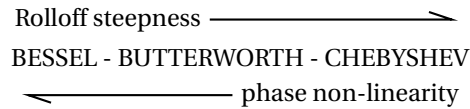

Figure 1.22: Steepness and phase linearity filter comparison.

Filter \ Properties	Advantages	Disadvantages
Butterworth	Maximally flat magnitude response in the pass-band	Overshoot and ringing in step response
Chebyshev	Better attenuation beyond the pass-band	Ripple in pass-band. Even more ringing in step response
Bessel	Excellent step response	Even poorer attenuation beyond the pass-band
Legendre	Better rolloff without ripple in pass-band	pass-band not so flat

Table 1.7: Butterworth, Chebyshev, Bessel and Legendre filter advantages/disadvantages.

The response of Butterworth, Chebyshev, Bessel and Legendre low pass filter is compared. To do this, polynomial tables given in Appendix A are directly used as the low-pass filter **denominator** transfer function. Figure 1.23 shows for example the 5th order of Butterworth, Chebyshev, Bessel and Legendre polynomials as a denominator ; only the module (expression 1.48) is plotted.

Filter	Butterworth	Chebyshev	Bessel	Legendre
roll-off rate for a given order	average	good	weak	average
group delay	good	bad	excellent	average
flatness of the frequency response	excellent	ripple in the pass-band	excellent	good
transient response	good	average	excellent	good

Table 1.8: Butterworth, Chebyshev, Bessel and Legendre filter comparison.

$$\begin{aligned}
P_{5\text{Butterworth}} &= (s+1)(s^2+0.618s+1)(s^2+1.618s+1) \\
P_{5\text{Chebyshev}_{3dB}} &= (5.6328s+1)(2.6525s^2+0.7619s+1)(1.0683s^2+0.1172s+1) \\
P_{5\text{Bessel}} &= (0.665s+1)(0.3245s^2+0.6215s+1)(0.4128s^2+1.1401s+1) \\
P_{5\text{Legendre}} &= (2.136s+1)(1.0406s^2+0.3196s+1)(2.0115s^2+1.5614s+1)
\end{aligned}$$

$$|P_5| = \begin{cases} \sqrt{\left(\frac{f^2}{f_c^2}+1\right)\left(\left(\frac{f^2}{f_c^2}+1\right)^2+0.618^2\frac{f^2}{f_c^2}\right)\left(\left(\frac{f^2}{f_c^2}+1\right)^2+1.618^2\frac{f^2}{f_c^2}\right)} \\ \sqrt{\left(5.6328^2\frac{f^2}{f_c^2}+1\right)\left(\left(2.6525\frac{f^2}{f_c^2}+1\right)^2+0.7619^2\frac{f^2}{f_c^2}\right)\left(\left(1.0683\frac{f^2}{f_c^2}+1\right)^2+0.1172^2\frac{f^2}{f_c^2}\right)} \\ \sqrt{\left(0.665^2\frac{f^2}{f_c^2}+1\right)\left(\left(0.3245\frac{f^2}{f_c^2}+1\right)^2+0.6215^2\frac{f^2}{f_c^2}\right)\left(\left(0.4128\frac{f^2}{f_c^2}+1\right)^2+1.1401^2\frac{f^2}{f_c^2}\right)} \\ \sqrt{\left(2.136^2\frac{f^2}{f_c^2}+1\right)\left(\left(1.0406\frac{f^2}{f_c^2}+1\right)^2+0.3196^2\frac{f^2}{f_c^2}\right)\left(\left(2.0115\frac{f^2}{f_c^2}+1\right)^2+1.5614^2\frac{f^2}{f_c^2}\right)} \end{cases} \quad (1.48)$$

It clearly appears on figure 1.23 differences concerning frequency response between Butterworth, Chebyshev, Bessel and Legendre filters. All these filters has been plotted with a cutoff frequency referred to a -3dB attenuation. Thereby, despite the same order, Chebyshev filter has the faster rolloff, then come Legendre, Butterworth and the slower is the Bessel filter. Far after the cutoff frequency, the slope becomes the same for all 5th order filters ($\propto f^{-5}$) but not the attenuation for a given $\frac{f}{f_c}$.

The down side of a fast rolloff is the increasing of the transit time in the case of step response as it is show in figure 1.24. Time response of a Chebyshev filter clearly shows oscillations which increase transient time.

Butterworth frequency response

Figure 1.25 illustrates the main properties of butterworth filters which is the flatness in the pass-band ; particularly for high order.

Butterworth attenuation plot on the left side of figure 1.25 could be used to determined the order of needed Butterworth filter for a given A_{min} and f_s (Fig. 1.21).

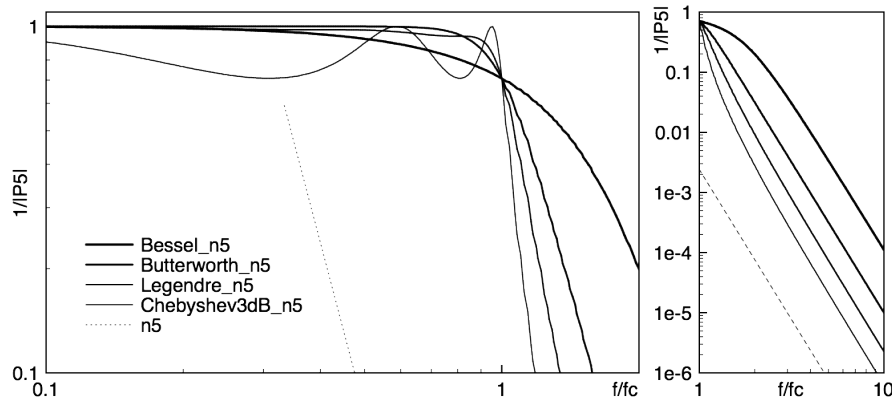

Figure 1.23: Frequency response of a Butterworth, Chebyshev, Bessel and Legendre 5th order low pass filter around cutoff frequency and far after it. Dashed line represent a f^{-5} slope for comparison to 5th order filter rolloff.

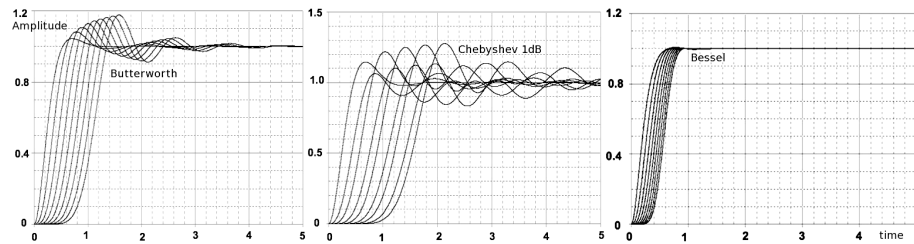

Figure 1.24: Normalized ($f_0 = 1$) time response (step) of multipole (2 to 10) Butterworth, Chebyshev 1dB and Bessel filters.

Chebyshev frequency response

Figure 1.26 shows the ripple in the pass-band of a Chebyshev low pass filter (3dB) for order from 2 to 5. It also appears that H_0 (numerator) is different from 1 for **even order**. For an even order Chebyshev filter with a ripple factor of 3 dB (which correspond to $\epsilon = 1$), the numerator is equal to $\frac{1}{\sqrt{1+\epsilon^2}} \approx 0.71$.

Figure 1.27 shows more precisely the difference in H_0 between odd ($n=5 \rightarrow H_0 = 1$) and even ($n=4 \rightarrow H_0 \approx 0.707$) order. It also illustrates of how it is possible to determine the order of a Chebyshev filter by simply counting the ripple number on the transfer function.

Amplitudes of the ripples in the pass-band is constrained by the $|H|_{max} - A_{max}$ and f_c (Fig. 1.21). Sometimes, ripple factor needs to be smaller than 3dB. It is easy to find Chebyshev polynomials table with a ripple factor of 1 dB*, 0.5 dB or 0.1 dB. In Figure 1.29, is plotted the transfer function of a Chebyshev low-pass filter with a

*Chebyshev polynomials table is given in Appendix A for a ripple factor of 3 and 1 dB

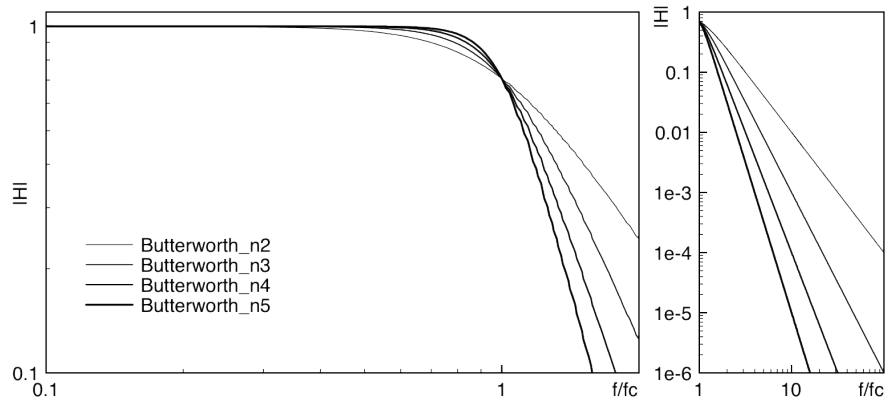

Figure 1.25: Frequency response of a Butterworth low pass filter for $n = 2$ to 5.

ripple factor of 1 dB ($\epsilon = 0.5$) and order going from 2 to 5. The H_0 of even order is set at $\frac{1}{\sqrt{1+0.5^2}} \approx 0.894$ as it is shown in figure 1.29.

Finally, a comparison between two Chebyshev low pass filters with different ripple factor is plotted in figure 1.30. Even if the cutoff frequency is referred to a different level (-1 dB and -3 dB), it appears that the larger the ripple factor, the faster the rolloff.

Bessel frequency response

Figure 1.31 show Bessel low pass filter transfer function from the 2nd to the 5th order. The rolloff is much slower than for other filters. Indeed, Bessel filter maximizes the flatness of the group delay curve in the passband (Fig. 1.32) but not the rolloff. So, for a same attenuation in the stop band (A_{min}), a higher order is required compared to Butterworth, Chebyshev or Legendre filter.

Legendre frequency response

To complete this inventory, Legendre low-pass filter frequency response is plotted in figure 1.33 for $n = 2$ to 5.

Legendre filter is characterized by the maximum possible rolloff consistent with monotonic magnitude response in the pass band. But monotonic does not flat, as we can see in figure 1.34.

As for Chebyshev filter, it is possible to count the number of "ripples" to find the order from a plotted transfer function.

1.6 Switched capacitor filters

A switched capacitor electronic circuit works by moving charges into and out of capacitors when switches are opened and closed. Filters implemented with these ele-

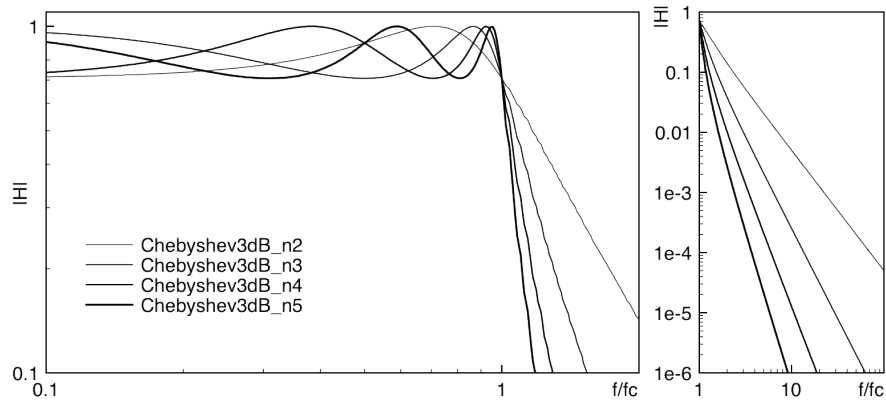

Figure 1.26: Frequency response of a Chebyshev ($\epsilon = 1$) low pass filter for $n = 2$ to 5.

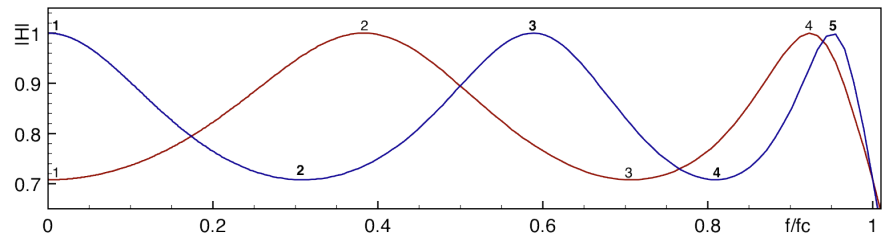

Figure 1.27: Zoom in the passband of the frequency response of a Chebyshev ($\epsilon = 1$) low pass filter for $n = 4$ and 5.

ments are termed "switched-capacitor filters".

1.6.1 Switched capacitor

Figure 1.35 give the circuit of a switched capacitor resistor, made of one capacitor C and two switches S_1 and S_2 which connect the capacitor with a given frequency alternately to V_{in} and V_{out} . Each switching cycle transfers a charge from the input to the output at the switching frequency. When S_1 is closed while S_2 is open, the charge stored in the capacitor C is $q_{in} = CV_{in}$ *, when S_2 is closed, some of that charge is transferred out of the capacitor, after which the charge that remains in capacitor C is $q_{out} = CV_{out}$.

Thus, the charge moved out of the capacitor to the output is $q_T = q_{in} - q_{out} = C(V_{in} - V_{out})$. Because this charge q_T is transferred each T_S^\dagger , the rate of transfer of charge per unit time ‡ is given by expression 1.49.

* $q=CV$, q the charge on a capacitor C with a voltage V between the plates.

$^\dagger T_S$ Periodicity of switch opening and closing

‡ The rate of flow of electric charge is a current $I[A]$.

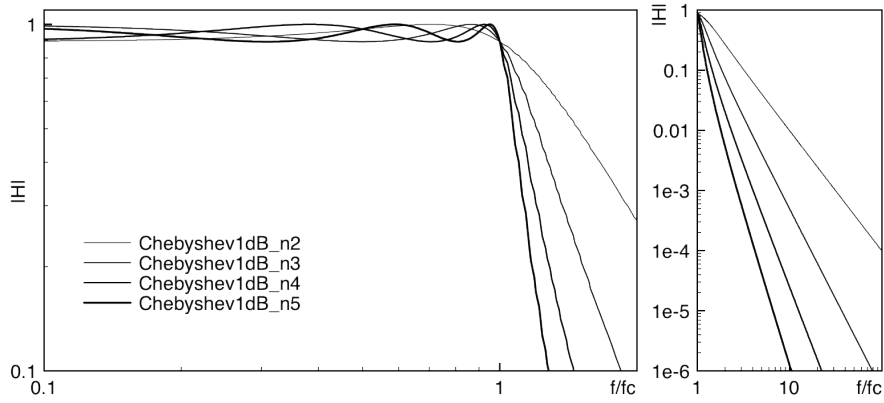

Figure 1.28: Frequency response of a Chebyshev ($\epsilon = 0.5$) low pass filter for $n = 2$ to 5 order filter rolloff.

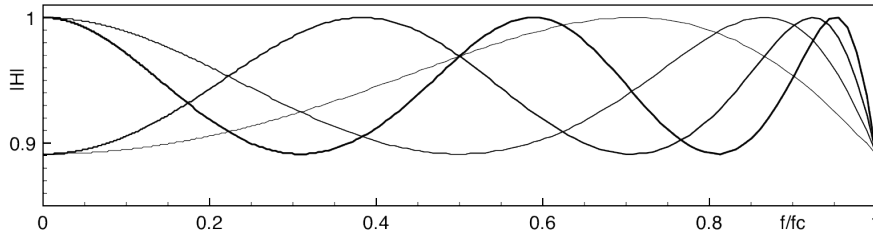

Figure 1.29: Zoom in the passband of the frequency response of a Chebyshev ($\epsilon = 0.5$) low pass filter for $n = 2$ to 5.

$$I = \frac{qT}{T_S} = \frac{C(V_{in} - V_{out})}{T_S} \quad (1.49)$$

Expression 1.49 give a link between V and I , and then the impedance* of the switched capacitor which could be expressed as a resistor (expression 1.50).

$$R = \frac{T_S}{C} \quad (1.50)$$

Switching capacitor behaves like a lossless resistor whose value depends on capacitance C and switching frequency $\frac{1}{T_S}$. This reduces energy consumption for embedded applications (such as space mission).

*the impedance of the capacitor could be considered static for a frequency smaller than $\frac{1}{T_S}$

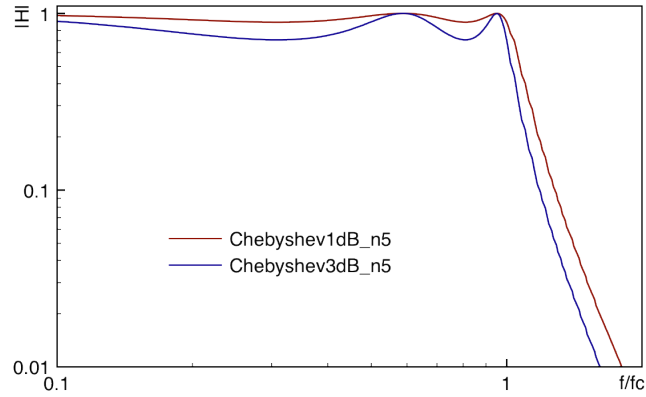

Figure 1.30: Comparison between frequency response of two Chebyshev low pass filters of 5th order, one with a ripple factor of 1 dB, and the other with 3 dB.

1.6.2 Switched capacitor filters

Because switching capacitor act as a resistor, switched capacitors can be used instead of resistors in the previous filter circuits (RC, RLC, Sallen-Key ...). A $R = 10k\Omega$ can be replaced by a switched capacitor following the expression 1.50. Using a switching clock $f_s = \frac{1}{T_s} = 50kHz$, the capacitor is given by equation 1.51.

$$R = 10k\Omega \quad \equiv \quad C = \frac{1}{10k\Omega \times 50kHz} = 2nF \quad (1.51)$$

A variation of the switching frequency leads to a variation of the equivalent resistance R . If f_s increases, $R = \frac{1}{C \times f_s}$ decreases. This link between frequency and equivalent resistance value could be used to modify a filter cutoff frequency by adjusting the switching frequency.

The cutoff frequency of a RC switched capacitor filter (Fig. 1.36) is expressed by equation 1.52.

$$f_c = \frac{1}{2\pi R_{equiv} C_2} = \frac{C_1 \times f_s}{2\pi C_2} \quad (1.52)$$

If the switching frequency f_s increases, the cutoff frequency f_c increases also.

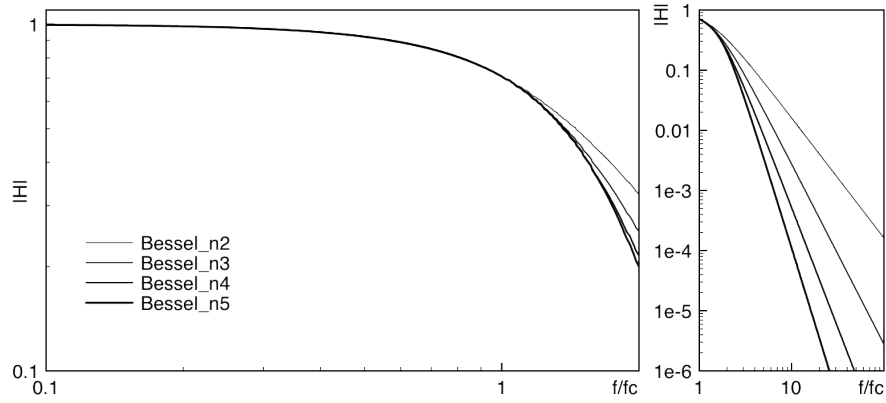

Figure 1.31: Frequency response of a Bessel low pass filter for $n = 2$ to 5 .

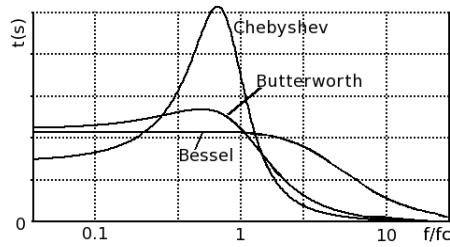

Figure 1.32: Comparison of the delay time as a function of frequency ($\frac{f}{f_c}$) between a Bessel, a Butterworth and a Chebyshev low-pass filter ($n=4$).

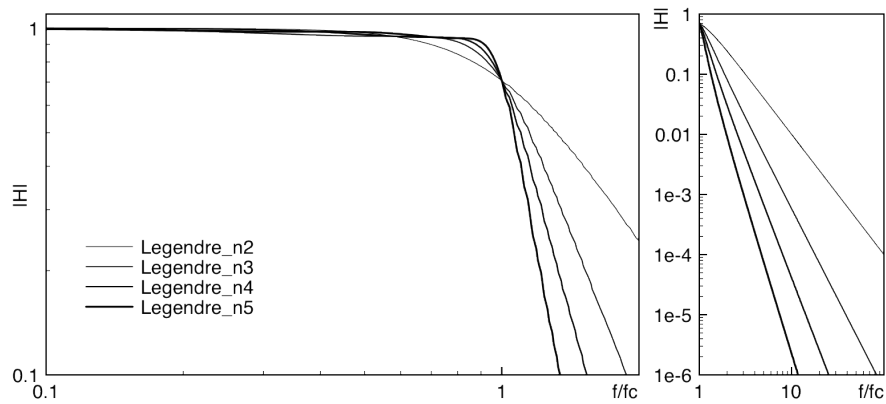

Figure 1.33: Frequency response of a Legendre low pass filter for $n = 2$ to 5

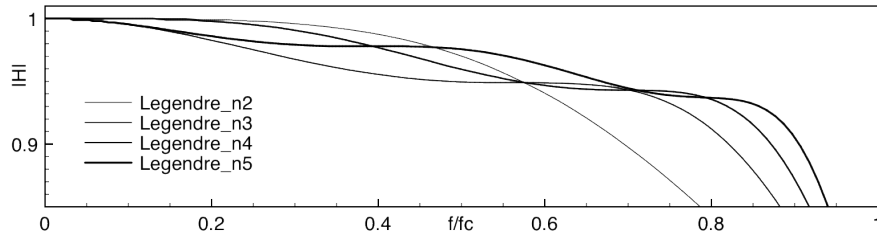

Figure 1.34: Zoom on the passband of the frequency response of a Legendre low pass filter for $n = 2$ to 5.

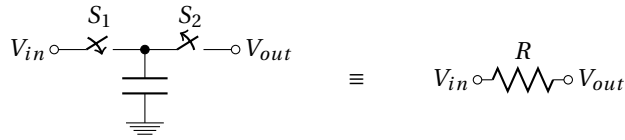

Figure 1.35: Equivalence between Resistor and Switched Capacitor.

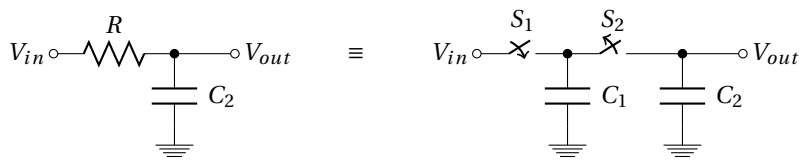

Figure 1.36: Equivalence between RC filter and switched capacitor filter.

CHAPTER 2

DC/DC CONVERTERS

2.1 Introduction

A DC/DC converter is an electronic circuit which converts a DC (Direct Current) source from one voltage level to another. Power for a DC/DC converter can come from any suitable DC sources, such as batteries, solar panels, rectifiers and DC generators.

DC/DC converter is a class of switched-mode power supply containing at least two semiconductor switches (a diode and a transistor) and at least one energy storage element, a capacitor, inductor, or the two in combination. Filters made of capacitors (sometimes in combination with inductors) are normally added to the output of the converter to reduce output voltage ripple.

2.1.1 Advantages/Disadvantages

Pros :

DC/DC converters offer three main advantages compared to linear regulators :

1. **Efficiency** : Switching power supplies offer higher efficiency than traditional linear power supplies*. Unlike a linear power supply, the pass transistor of a switching-mode supply continually switches between low-dissipation, full-on and full-off states[†], and spends very little time in transitions to minimize wasted energy. Ideally, a switched mode power supply dissipates no power. This higher efficiency is an important advantage of a switched mode power supply.

*A linear power supply regulates the output voltage by continually dissipating power (Joule dissipation) in a pass transistor (made to act like a variable resistor). The lost power is $P_{lost} = (V_{out} - V_{in})I_{load}$.

[†]A switching regulator uses an active device that switches "on" and "off" to maintain an average value of output.

2. **Size** : Switched mode power supplies may also be substantially smaller and lighter than a linear supply due to the smaller transformer size and weight; and due to the less thermal management required because less energy is lost in the transfer.
3. **Output voltages can be greater than the input or negative** : DC/DC converter can transform input voltage to output voltages that can be greater than the input (boost), negative (inverter), or can even be transferred through a transformer to provide electrical isolation with respect to the input. By contrast linear regulator can only generate a lower voltage value than input one.

Cons :

However, DC/DC converter are more complicated ; their switching currents can cause electrical noise problems if not carefully suppressed*. Linear regulators provide lower noise ; their simplicity can sometimes offer a less expensive solution. Even if the most of low noise electronic circuits can tolerate some of the less-noisy DC/DC converters, some sensitive analog circuits require a power supply with so little noise that it can only be provided by a linear regulator.

2.1.2 Applications

DC/DC converter is used in many domestic products to supply whatever voltages are needed in personal computers, mobile phone chargers, as well as in embedded instrument powered by battery and/or solar generator. This is typically used for DC distribution in satellite (see Fig. 2.1). Indeed, aerospace industry requires small, lightweight, and efficient power converters.

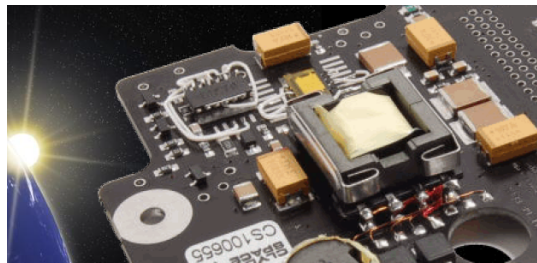

Figure 2.1: DC/DC converter for space applications - CLYDE SPACE

2.2 DC/DC converters

We will discuss 4 different common topologies of DC/DC converter:

*DC/DC converters have switching noise at the switching frequency and its harmonics. Electrical noise can be emitted from the supplying power lines as RF noise which should be prevented with proper filtering.

1. step-down voltage converter \Rightarrow *buck* converter.
2. step-up voltage converter \Rightarrow *boost* converter.
3. inverter voltage converter \Rightarrow inverting *buck-boost* converter.
4. isolated* voltage converter \Rightarrow *flyback* converter.

2.2.1 Buck converters

Buck converter is a **step-down DC/DC converter**. It is composed of an inductor L and two switches (usually a transistor and a diode) that control the inductor (see figure 2.2). They alternate between connecting the inductor to source voltage to store energy in the inductor and discharging the inductor into the load.

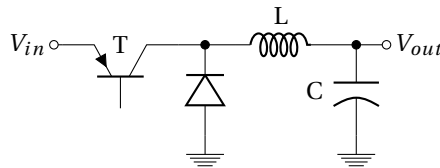

Figure 2.2: *Buck* topology of a step-down DC/DC converter.

For the purposes of analysis it is useful to consider that components are perfect (Fig. 2.3). Particularly, the switch and the diode have zero voltage drop when they conduct (*i.e.* ON) and zero current flow when they block (*i.e.* OFF). Moreover, the inductor L has zero series resistance. Further, it is assumed that the input and output voltages do not change over the course of a cycle[†].



Figure 2.3: Simplified *Buck* converter circuit for the two configurations : left when the transistor T conducts (ON); right when it is OFF

Continuous operation $\equiv I_L \neq 0 \forall t$

We consider that the current through the inductor L never falls to zero during the commutation cycle; this imply minimum switching frequency and capacitor value.

*ensure galvanic isolation between the input and the output

[†]this would imply the output capacitance C being large enough

Charge phase T_{ON} : When the transistor conducts (diode is reverse biased), the voltage across the inductor ($V_L = V_{in} - V_{out}$) is considered as a constant voltage to a first approximation. So the current through the inductor I_L rises linearly with time following expression 2.1 with a $\frac{V_L}{L}$ slope*.

$$dI_L = \frac{1}{L} \int_{t=T_{ON}} V_L dt \quad (2.1)$$

During the charge phase T_{ON} , I_L increase by the value $\Delta I_{L_{ON}}$ given by expression 2.2.

$$\Delta I_{L_{ON}} = \frac{V_{in} - V_{out}}{L} T_{ON} \quad (2.2)$$

Discharge phase T_{OFF} : When the transistor is no longer biased (*i.e.* OFF), diode is forward biased and conducts. The voltage across the inductor becomes equal to $-V_{out}^\dagger$ and I_L flows to the load through the diode. I_L decrease by the value $\Delta I_{L_{OFF}}$ given by expression 2.3 due to the linear discharge of the inductor.

$$\Delta I_{L_{OFF}} = \frac{-V_{out}}{L} T_{OFF} \quad (2.3)$$

Entire switching cycle : In a steady-state operation condition, I_L at $t = 0$ is equal to I_L at $t = T = T_{ON} + T_{OFF}$. So the increase of I_L during T_{ON} is equal[‡] to the decreasing during T_{OFF} .

$$\Delta I_{L_{ON}} + \Delta I_{L_{OFF}} = 0 \quad (2.4)$$

We can then establish the relationship 2.5 which allows to obtains the conversion factor between V_{in} and V_{out} as a function of the duty cycle $D = \frac{T_{ON}}{T}$. It appears that V_{out} varies linearly with the duty cycle for a given V_{in} .

$$(V_{in} - V_{out})T_{ON} - V_{out}T_{OFF} = 0 \quad \xrightarrow{D = \frac{T_{ON}}{T_{ON} + T_{OFF}}} \boxed{V_{out} = DV_{in}} \quad (2.5)$$

As the duty cycle D is equal to the ratio between T_{ON} and the period T , it cannot be more than 1. Therefore, $V_{out} \leq V_{in}$. This is why this converter is named a step-down converter.

Figure 2.4 shows the evolution of voltage and current of an ideal *buck* converter during charge and discharge phases.

2.2.2 Boost converters

A boost converter (step-up converter) is a DC/DC converter with an **output voltage value greater than its input voltage value**. The key principle that drives the *boost*

*We consider here the current charge of the inductor. The capacitor is assumed charge at a constant voltage.

[†]Voltage drop across diode is neglected.

[‡]in absolute value, but not in sign.

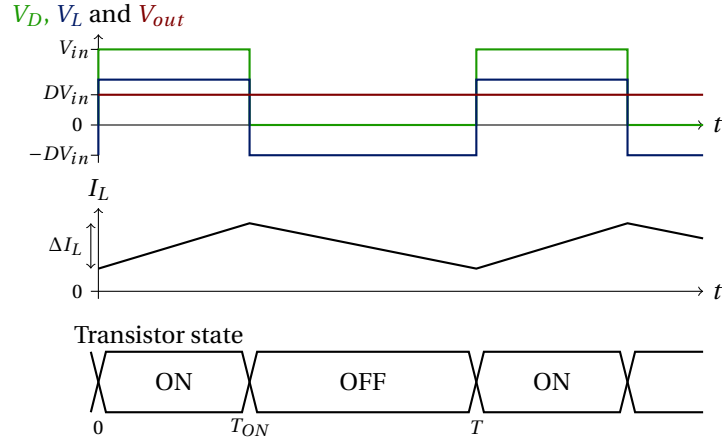

Figure 2.4: Voltages and current as a function of time for an ideal *buck* converter operating in continuous mode.

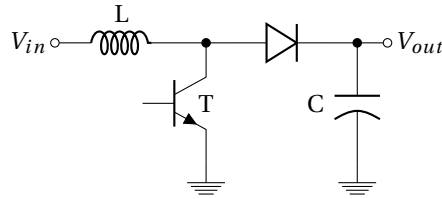

Figure 2.5: *Boost* topology of a step-up DC/DC converter.

converter is the tendency of an inductor to oppose current changes. A schematic of a *boost* converter is shown in figure 2.5.

When the transistor conduct (*i.e.* ON), the current flows through the inductor and energy is stored in it.

When the transistor block the current (*i.e.* OFF), the energy stored in the inductor L is returned holding the current through it. To do this, the L voltage polarity changes such that it is added to the input voltage. Thus, the voltage across the inductor and the input voltage are in series and they charge together the output capacitor to a voltage higher than the input voltage.

As for *buck converter*, conversion factor of a *boost* converter could be expressed as a function of the duty cycle and is given in equation 2.6.

$$V_{out} = \frac{1}{1-D} V_{in} \quad (2.6)$$

2.2.3 Buck-boost inverting converters

A *Buck-boost* converter is a DC/DC converter that has an output voltage magnitude that is either greater than* or smaller than the input voltage magnitude. The *Buck-boost* converter presented in figure 2.6 is also called inverting converter because its **output voltage is of the opposite polarity as the input**.

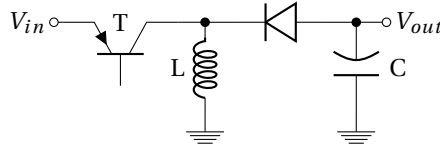

Figure 2.6: *Buck-boost* Inverting topology of DC/DC converter. V_{out} is of the opposite polarity as V_{in} .

When the transistor conduct (*i.e.* ON), the input voltage source is directly connected to the inductor. This results in accumulating energy in L. In this step, this is the capacitor C which supplies energy to the output load.

When the transistor blocks (*i.e.* OFF), the inductor is connected to the capacitor, so energy is transferred from L to C and therefore also to the output load.

Conversion factor is given in equation 2.7 as a function of the duty cycle D.

$$V_{out} = -\frac{D}{1-D} V_{in} \quad (2.7)$$

Compared to the *buck* and *boost* converters[†], *buck-boost* converter has an output voltage opposite to that of the input and which can vary continuously from 0 to ∞ .

2.2.4 Flyback converters

The *flyback* converter is used when it is needed to have a **galvanic isolation** between the input and the outputs. The *flyback* converter is a *buck-boost* converter with the **inductor split to form a transformer**, so that the voltage ratios are multiplied with an additional isolation advantage.

The schematic of a *flyback* converter can be seen in figure 2.7. It is equivalent to that of a *buck-boost* converter but with a transformer instead of inductor. Therefore the operating principle of both converters is very similar :

When the transistor conducts, the primary of the transformer is directly connected to the input voltage source. The primary current and magnetic flux in the transformer increase, storing energy in the transformer. The voltage induced in the secondary winding is negative, so the diode is reverse-biased (*i.e.* blocked). The output capacitor supplies energy to the output load.

*in absolute magnitude.

[†]The output voltage ranges for a buck and a boost converter are respectively 0 to V_{in} and V_{in} to ∞ .

When the transistor is blocked, the primary current and magnetic flux drops. The secondary voltage is positive, forward-biasing the diode, allowing current to flow from the transformer. The energy from the transformer core recharges the capacitor and supplies the load.

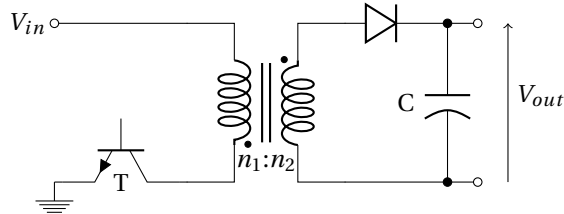

Figure 2.7: *Flyback* topology of an isolated DC/DC converter.

Conversion factor is given by equation 2.8 as a function of the duty cycle D .

$$V_{out} = \frac{n_2}{n_1} \frac{D}{1-D} V_{in} \quad (2.8)$$

A DC/DC converter using a transformer as the *flyback* converter is unavoidable if there is a large difference of voltage between V_{in} and V_{out} . Indeed, using *buck*, *boost* or *buck-boost* converter, an output voltage value 100 times larger (or smaller) than the input require a duty cycle of the order of 0.99 or 0.01 which is not easy to realized (considering that rise and fall time are not 0).

Numerical application : $V_{in} = 300V, V_{out} = 5V$: a *buck* converter require a 0.017 duty cycle (!) while with a *flyback* converter it is possible to stay with a duty cycle close to 50 % by choosing a transformer with a ratio $\frac{n_2}{n_1} = \frac{V_{out}}{V_{in}} \approx 0.017$.

2.3 Control

A voltage regulator is designed to automatically maintain a constant voltage level. It include **negative feedback control loops**.

We have see that changing the duty cycle of the switching (*i.e.* Transistor ON/OFF) controls the steady-state output with respect to the input voltage. Then, act on the duty cycle of the transistor driver allow to regulate the output voltage around a constant voltage* even if V_{in} , loads or other parameters change.

*by using a proper filtering with a large capacitor.

2.3.1 Feedback regulation

Feedback principle consist in subtracting* from the "input signal" a fraction of the output one. However, in the case of a DC/DC converter, the "input signal" is more the duty cycle D than V_{in} (Fig. 2.8).

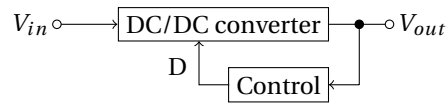

Figure 2.8: Principle of a DC/DC converter feedback voltage regulation. D is the duty cycle of the switching transistor.

2.3.2 Voltage regulation

To do a voltage regulation with a DC/DC converter, a sample of the output voltage is compared to a reference voltage to establish a small error signal V_{err} . This error signal is used to modulate the duty cycle D of the transistor driver (Fig. 2.9). This modulation of the duty cycle is simply obtained by comparing the error signal with a triangle signal (Fig. 2.10). Duty cycle modulation is also called Pulse Width Modulation (PWM) because if the duty cycle changes, the pulse width also changes.

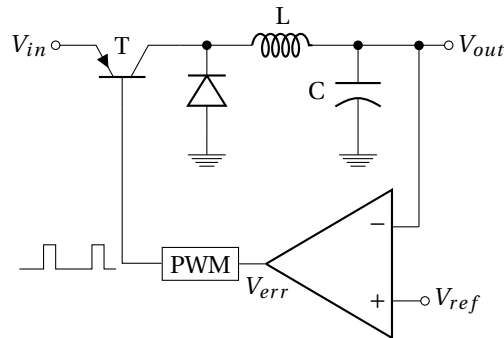

Figure 2.9: Voltage regulation of a *Buck* DC/DC converter by using Pulse Width Modulation (PWM).

Regulation is finally obtained because feedback changes the duty cycle from V_{out} then moves the V_{out} to reduce the error signal to zero, thus completing the control loop. The higher the error voltage, the longer the transistor conducts[†]. V_{err} is derived in the feedback system from the error amplifier that amplifies the difference between the output voltage and the reference voltage.

*Only negative feedback is considering here, because stable operation is required. Moreover, a frequency compensation is needed.

[†]considering that the output voltage value is lower than what we want

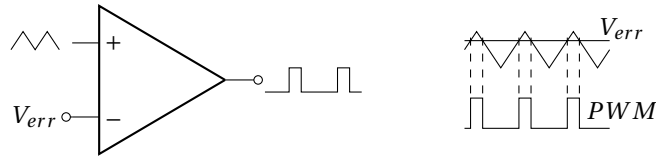

Figure 2.10: Pulse Width Modulation (PWM).

This type of voltage regulation of a DC/DC converter is classified as a voltage-mode controller* because the feedback regulates the output voltage. For analysis we can assume that if the loop gain is infinite, the output impedance for an ideal voltage source is 0Ω .

*Another type of control is current-mode control. This method regulates the output current and, with infinite loop gain, the output is a high-impedance source.

CHAPTER 3

PHASE LOCKED LOOP

3.1 Introduction

THE Phase Locked Loop (PLL) plays an important role in modern electronic and particularly for space communications. Indeed, PLL is a crucial part of modulator, demodulator or synchronization systems. As example of space application (Fig. 3.1), PLL is particularly essential to estimate the instantaneous phase of a received signal, such as carrier tracking from Global Positioning System (GPS) satellites.

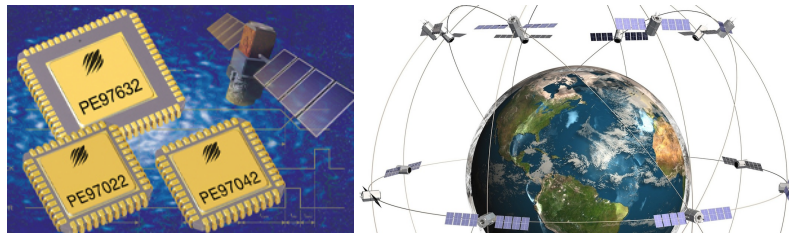

Figure 3.1: PLLs used for space applications (Peregrine Semiconductor); GPS constellation around the Earth.

PLL allows to extract signals from noisy transmission channels. Indeed, communications between satellites and ground stations are usually buried in atmospheric noise or some type of interferences (frequency selective fading* or doppler shift[†]) which one manage by a PLL.

PLL circuits can also be used to distribute clock signal, or set up as frequency multipliers or dividers for frequency synthesis.

*Frequency selective fading : Radio signal arrives at the receiver by two different paths.

[†]Doppler shift : Shift in frequency for a receiver moving relative to the emitter

3.2 Description

PLL is a feedback electronic circuit (control system) as shown in figure 3.2. It includes an **oscillator** which is constantly adjusted in order to match the **instantaneous phase** (therefore the frequency) of the PLL input signal. The oscillator is a **Voltage Controlled Oscillator (VCO)*** whose frequency varies with an **"error" signal** $\epsilon \approx V_{VCO}$. This "quasi-DC" voltage come from a **phase detector** (ϕ comp.). It is proportional to the phase difference between the input signal which varies in frequency as $f_{in}(t)$ and VCO output frequency $f_{out}(t)$. Noises are suppressed after phase comparison, by adding a filter before the VCO. Thus, PLL recovers, at the output, the original signal from a noisy version of the received signal.

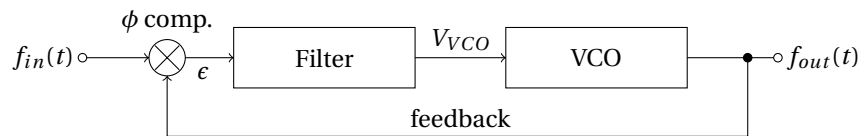

Figure 3.2: Block diagram of a PLL.

Phase comparison can also be made after a division of the VCO frequency, which allows to have a PLL output signal with a larger frequency. This technique is used for frequency synthesis.

☞ A Phase Locked Loop is thus mainly composed by two key ingredients :

- **Phase detector/comparator more or less associated to a filter**
- **Voltage Controlled Oscillator (VCO)**

3.2.1 Phase detector/comparator

One key element of the PLL, is the phase comparator. A phase comparator is a frequency mixer, analog multiplier or logic circuit that generates a voltage signal whose mean value is proportional to the difference in phase between two input signals.

Analog phase detector

Mixing (or product) of two sine waves at similar frequencies as f_{in} and f_{out} gives, in spectrum, a signal at the sum and at the difference of the two input signal frequencies[†]. The high frequency at $f_{in} + f_{out}$ is removed by filter. The low frequency (static if $f_{in} = f_{out}$) could be expressed as a function of phase difference $\Delta\phi$ (equation 3.1).

*A VCO is an electronic oscillator (output) designed to be controlled in oscillation frequency by a voltage input. The frequency of oscillation is varied by the applied DC voltage.

[†] $\sin(f_{in})\sin(f_{out}) = \frac{\cos(f_{in}-f_{out})-\cos(f_{in}+f_{out})}{2}$

$$\begin{aligned} & \sin(2\pi f_{in}t + \phi_{in}) \times \sin(2\pi f_{out}t + \phi_{out}) \\ \propto & \underbrace{\cos(\Delta\phi)}_{\text{static}} - \underbrace{\cos(2\pi(f_{in} + f_{out})t + \phi_{in} + \phi_{out})}_{\text{filtered signal}} \end{aligned} \quad (3.1)$$

So multiplication allows to detect phase difference between two sine waves. This is why phase comparator is currently represented by the symbol \otimes as in figure 3.2.

Digital phase detector

Phase locked loop device as the popular CD4046 integrated circuit include two kind of digital phase comparators :

- **Type I** phase comparator is designed to be driven by analog signals or square-wave digital signals and produces an output pulse at twice the input frequency. It produces an output waveform, which must be filtered to drive the VCO.
- **Type II** phase comparator is sensitive only to the relative timing of the edges of the inputs. In steady state (both signals are at the same frequency), it produces a constant output voltage proportional to the phase difference. This output will tend not to produce ripple in the control voltage of the VCO.

Type I phase detector : XOR The simplest phase comparator is the eXclusive OR (XOR) gate. A XOR gate is a digital logic gate which compute the binary addition* which is symbolized by \oplus . XOR truth table is shown in figure 3.1.

A	B	A \oplus B
0	0	0
0	1	1
1	0	1
1	1	0

Table 3.1: XOR truth table.

Type I comparator will be appropriate for square waves (v_1 and v_2 in figure 3.3) but could also be used with sine wave inputs. Its operation is highly dependent on the duty cycle of the input signals and is not really usable for duty cycle too different from $\frac{1}{2}$.

The phase difference between v_1 and v_2 could be expressed as a function of the pulse width Δt and the frequency as expression 3.2.

$$\Delta\phi = 2\pi \frac{\Delta t}{T} = 2\pi f \Delta t \quad (3.2)$$

*Binary addition \equiv addition modulo 2.

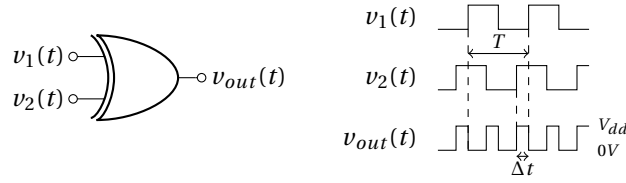

Figure 3.3: XOR phase comparator.

For a duty cycle = $\frac{1}{2}$, XOR produces pulse train with twice the frequency of v_1 and v_2 . This periodic square wave signal v_{out} has a duty cycle $D_{v_{out}}$ given by expression 3.3, function of input phase difference $\Delta\phi$.

$$D_{v_{out}} = \frac{\Delta\phi}{\pi} \quad (3.3)$$

Then, the output of the XOR gate can be expressed as a static value $\overline{V_{out}}$ and harmonics at the $\frac{2}{T}$ frequency at least as a Fourier series (equation 3.4 with v_n and ϕ_n the amplitude and the phase of the n^{th} harmonic at the frequency $\frac{2n}{T}$).

$$v_{out} = \underbrace{\overline{V_{out}}}_{static} + \underbrace{\sum_{n=1}^{n \rightarrow \infty} v_n \sin\left(2\pi \frac{2n}{T} t - \phi_n\right)}_{harmonics} \quad (3.4)$$

This pulse train is averaged* before the VCO to keep only the static signal.

The averaging value of the XOR output could be linked to the pulse width as expressed on 3.5.

$$\overline{V_{out}} = \frac{2\Delta t}{T} V_{dd} \quad (3.5)$$

Finally, we could obtain the information about the phase difference $\Delta\phi$ from the XOR output averaging value using the expression 3.6. This expression allows to show the phase comparator gain K_p .

$$\overline{V_{out}} = \frac{\Delta\phi}{\pi} V_{dd} = K_p \Delta\phi \quad (3.6)$$

The characteristics of an XOR phase comparator is represented in figure 3.4. It is periodic in $\Delta\phi$ with period of 2π . The range $0 \leq \Delta\phi \leq \pi$ is the range where the PLL can operate in the locked condition.

The transfer function of this phase comparator on a linear part is given by expression 3.7. K_p is called the **gain of the phase detector**.

$$\boxed{\frac{\overline{V_{out}}}{\Delta\phi} = K_p = \frac{V_{dd}}{\pi} \Big|_{0 \leq \Delta\phi \leq \pi} \quad [\text{V/Rad}]} \quad (3.7)$$

*The loop filter acts as a low pass filter, smoothing this full-swing logic-output signal.

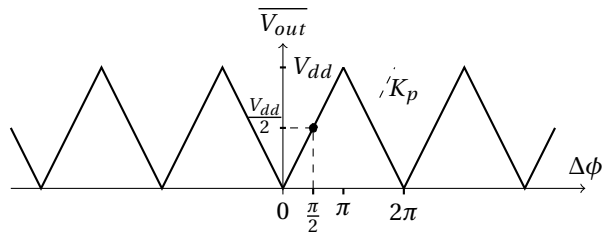

Figure 3.4: Periodic characteristic of an XOR phase comparator and a typical operating point. The slope K_p is the gain of the comparator.

When PLL is in lock with this type of comparator, the steady-state phase difference at the inputs is near $\frac{\pi}{2}$.

So, this kind of phase comparator generate always an output "digital" signal in the PLL loop. Therefore, despite low pass filter, it always remain residual ripples, and consequent periodic phase variations.

Type II phase detector : charge pump By contrast to the type I comparator, the type II phase detector generates output pulses only when there is a phase error between the input and the VCO signal.

- **If the two input are in phase :** The phase detector looks like an open circuit and the loop filter capacitor then acts as a voltage-storage device, holding the voltage that gives the VCO frequency.
- **If the input signal moves away in frequency :** The phase detector generates a train of short pulses*, charging the capacitor of the filter to the new voltage needed to keep the VCO locked.

So, the output pulses disappear entirely when the two signals are in lock[†]. This means that there is no ripple present at the output to generate periodic phase modulation in the loop, as there is with the type I phase detector.

3.2.2 Voltage Control Oscillator - VCO

The other key ingredient of the PLL, is the VCO. It exist two different types of controlled oscillators :

- Resonant/Harmonic oscillators (> 50 MHz)
- Relaxation oscillators (< 50 MHz)

*The short pulses contain very little energy and are easy to filter out of the VCO control voltage. This results in low VCO control line ripple and therefore low frequency modulation on the VCO.

†A charge pump phase detector must always have a "dead frequency band" where the phases of inputs are close enough that the comparator detects no phase error. So, charge pump introduce necessarily a significant peak-to-peak jitter, because of drift within the dead frequency band.

For microwave applications, resonant oscillators implemented with devices as LC tank circuit is used. C value is adjusted (tuning) thanks to a varactor diode.

However, we will concentrate on non-microwave applications, and thus on the relaxation oscillators more easily implementable on integrated circuit. This is typically the VCO that we can find in the CD4046 PLL integrated circuit. V_{VCO} controls the charging and discharging currents through an external* capacitor C , and therefore determines the time needed to charge and discharge the capacitor to a pre-determined threshold level. As a result, the frequency f_{VCO} changes as a function of V_{VCO} .

If V_{VCO} evolves, a linear VCO transfer function can be expressed as equation 3.8.

$$\frac{f_{max} - f_{min}}{V_{max} - V_{min}} = K_0 \quad [\text{Hz/V}] \quad (3.8)$$

In practice V_{max} is limited by V_{DD} and V_{min} by $0V$ (or V_{SS}). Assuming a linear response as in figure 3.5, f_{max} and f_{min} are adjusted and therefore fix the gain K_0 .

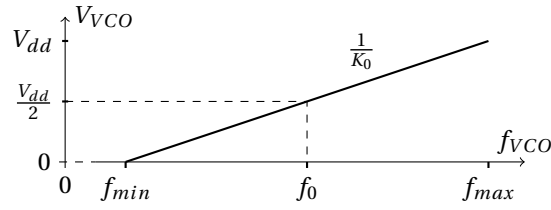

Figure 3.5: VCO characteristic : V_{VCO} as a function of f_{VCO} .

The VCO transfer function can also be expressed using the angular frequency ω_{VCO} (eq. 3.9).

$$\boxed{\frac{\omega_{VCO}}{V_{VCO}} = 2\pi K_0 = K_v \quad [\text{rad/V.s}]} \quad (3.9)$$

The VCO gain is generally expressed as a radian frequency per voltage; so its units are rad/V.s even if the "rad" is often omitted.

However, for a PLL, the phase instead of frequency is interesting. It is then more useful to express the phase output of the VCO :

$$\int \omega_{VCO}(t) dt = \phi_{VCO}(t) \quad \rightarrow \quad \frac{\omega_{VCO}(s)}{s} = \phi_{VCO}(s) \quad (3.10)$$

Then the transfer function between the phase and the input voltage of the VCO is given by expression 3.11

$$\frac{\phi_{VCO}(s)}{V_{VCO}(s)} = \frac{K_v}{s} \quad (3.11)$$

*not implemented on the CD4046 to allow tuning of the f_{VCO_0} center frequency.

3.3 Frequency range

Operating frequency range of a PLL is graphically represented in figure 3.6. Two main frequency ranges appear :

- Lock range
- Capture range

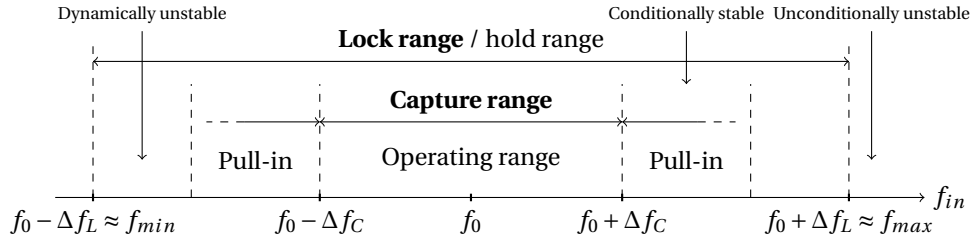

Figure 3.6: Scope of the 2 main frequency ranges of a PLL : Lock (or Hold) range and Capture range (more or less defines due to pull-in effect).

3.3.1 Lock range

The Lock range (also called Hold range) is the frequency range in which a PLL is able to stay locked. It correspond to a "static stable frequency range"; this means that the PLL remains locked if the input signal is a **fixed frequency** signal comprised in this range.

The Lock range is mainly defined by the VCO range.

Figure 3.4 shows that when the phase comparator is used on a PLL, the phase difference $\Delta\phi$ need to be small enough to stay on a linear regime. So, VCO is used to operate around a center frequency $f_{VCO_0} = f_0$ and around $V_{VCO_0} = \frac{V_{dd}}{2}$ * as it is represented in figure 3.5. Then, $\Delta\phi_{max} = \pi$ around this operating point (eq. 3.12 and Fig. 3.4).

$$0 \leq \Delta\phi \leq \pi \quad (3.12)$$

Knowing that $\Delta\phi$ must be included in $[0; \pi]$ range, we can expressed the maximum range in frequency at the output of the VCO as equation 3.13 (from Fig. 3.5 $\rightarrow f_{max} - f_{min} = K_0 V_{dd}$ and Fig. 3.4 $\rightarrow V_{dd} = \pi K_p$).

$$f_{max} - f_{min} = \pi K_0 K_p = \frac{K_v K_p}{2} \quad (3.13)$$

From this expression, lock range $2\Delta f_L = f_{max} - f_{min}$ is defined as equation 3.14.

*In this operating point, the two compared signals are in quadrature.

$$2\Delta f_L = \frac{K_v K_p}{2} \quad (3.14)$$

If f_{in} exceeds f_{max} (or if f_{in} becomes smaller than f_{min}), the PLL fails to keep $f_{VCO} = f_{in}$, and the PLL becomes unlocked. When the PLL is unlocked, the VCO generally oscillates at the frequency f_0 (the "free-running" of the VCO). The lock can be established again if the incoming signal frequency f_{in} gets close enough to f_0 i.e. as close as the Capture range.

The VCO output frequency f_{VCO} can be plotted (Fig. 3.7) as a function of the input PLL frequency f_{in} .

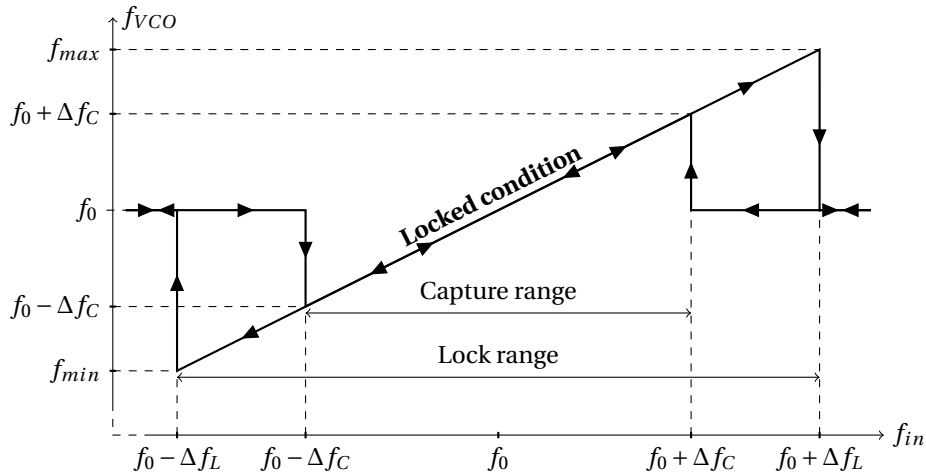

Figure 3.7: Hysteretic PLL characteristic.

This characteristic simply shows that $f_{VCO} = f_{in}$ in the locked condition, and that $f_{VCO} = f_0$ when the PLL is unlocked. A hysteresis is observed because the Lock range is larger than the Capture range.

3.3.2 Capture range

The capture range is the frequency range where the PLL is able to quickly **lock-in, starting from unlocked condition**. Indeed, in most practical applications, it is desirable that the locked state is obtained within a short time period. So, the capture range point out that the PLL can become locked within "one single-beat". This is called a **lock-in process**. Beyond this frequency range, a **pull-in process** also allows the PLL to lock, but slowly. There is obviously a blurred boundary between Capture range and pull-in range, but we can notice that :

- Lock-in process is much faster than pull-in process

- Capture range is smaller than pull-in range

Capture range refers to the dynamic behavior of the PLL loop. So $2\Delta f_L$ depends on the loop bandwidth. In the case of a single pole filter and a $\zeta > 0.5$, the Capture range is simply equal to the Lock range.

☞ Capture range is not necessarily centered on f_0 .

3.4 Frequency response

For a small phase difference ($\sin \phi \approx \phi$) between PLL input signal and VCO output, PLL can be accurately described by a linear model expressed as regard to the phase instead of frequency. Block diagram of this linear model is given in figure 3.8. $\frac{K_v}{s}$ the gain of the VCO is expressed as equation 3.11 as regard to the phase. The loop filter plays a crucial role in the frequency response of the PLL. Its transfer function is called $H_{filter}(s)$, or more simply $H(s)$.

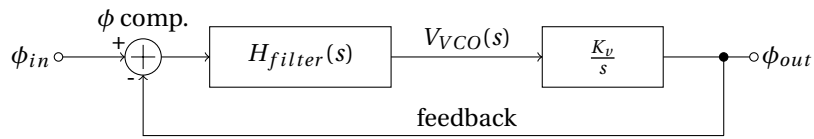

Figure 3.8: Block diagram of PLL on phase domain.

The PLL response can be written as 3.15.

$$\frac{\phi_{out}}{\phi_{in}} = \frac{\text{forward gain}}{1 + \text{loop gain}} = \frac{K_p \frac{K_v}{s} H(s)}{1 + K_p \frac{K_v}{s} H(s)} \quad (3.15)$$

The transfer function $H(s)$ of the filter averages the output of the phase comparator and suppresses noise of the input signal.

3.4.1 One pole loop filter

For a simple first order RC filter (Fig. 3.9), the $H(s)$ transfer function is given by expression 3.16

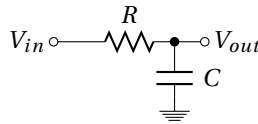

Figure 3.9: One pole filter used as PLL loop filter.

$$H(s) = \frac{V_{out}}{V_{in}} = \frac{1}{1 + RCs} \quad (3.16)$$

Using this one pole filter, the PLL response is expressed as 3.17.

$$\frac{\phi_{out}}{\phi_{in}} = \frac{1}{1 + \frac{1}{K_p K_v} s + \frac{RC}{K_p K_v} s^2} \quad (3.17)$$

Denominator could be rewritten as expression 3.18 to show the natural angular frequency $\omega_n = 2\pi f_n$ and the damping factor ζ of the PLL response.

$$1 + 2\zeta \frac{s}{\omega_n} + \frac{s^2}{\omega_n^2} \quad \left\{ \begin{array}{l} \omega_n = \sqrt{\frac{K_p K_v}{RC}} \\ \zeta = \frac{1}{2\sqrt{K_p K_v RC}} \end{array} \right. \quad (3.18)$$

The natural frequency of the PLL is a measure of the response time of the locked system. The damping factor is a measure of overshoot and ringing. Ideally, the natural frequency should be high and the damping factor should be near unity (critical damping). With a single pole filter, it is not possible to control the loop frequency and damping factor independently.

Assuming a critical damping (*i.e.* $\zeta = 1$): $RC = \frac{1}{4K_p K_v}$ and $\omega_n = 2K_p K_v$.

☞ In other words, the ability of the PLL to filter the input "frequency noise" is limited by the stable condition of the loop.

3.4.2 One pole - one zero loop filter

A One pole - one zero filter allows to adjust independently the band width of the PLL response and the damping factor. It is composed of two resistors and one capacitor (Fig. 3.10). The transfer function of this filter is given in expression 3.19 and plot in figure 3.11. It is characterized by two time constants: τ_1 and τ_2 .

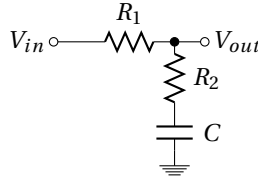

Figure 3.10: One pole - one zero filter used as PLL loop filter.

$$H(s) = \frac{V_{out}}{V_{in}} = \frac{1 + \tau_2 s}{1 + \tau_1 s} \quad \left\{ \begin{array}{l} \tau_1 = (R_1 + R_2)C \\ \tau_2 = R_2 C \end{array} \right. \quad (3.19)$$

Using this one pole - one zero filter, the PLL response is now expressed as 3.20.

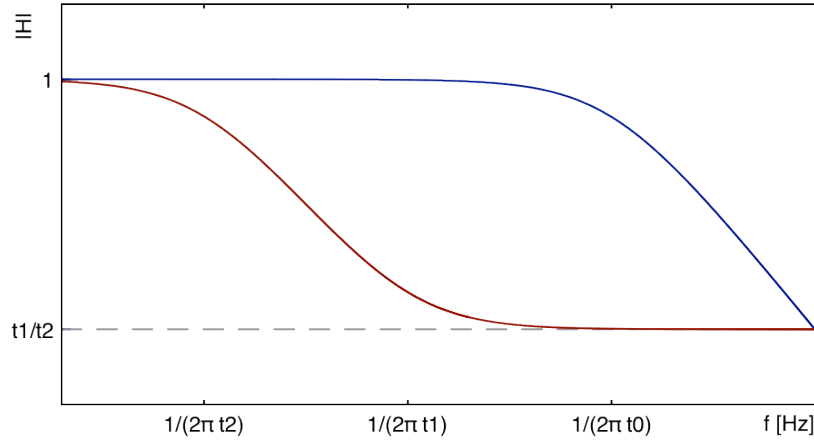

Figure 3.11: Amplitude Bode plot of a **one pole** ($RC=t_0$) and a **one pole - one zero** ($(R_1 + R_2)C=t_1$ and $R_2C=t_2$) filter .

$$\begin{aligned} \frac{\phi_{out}}{\phi_{in}} &= \frac{1}{1 + \frac{s}{K_p K_v} \frac{1 + \tau_1 s}{1 + \tau_2 s}} \\ &= \frac{1 + \tau_2 s}{1 + \frac{1 + K_p K_v \tau_2}{K_p K_v} s + \frac{\tau_1}{K_p K_v} s^2} \end{aligned} \quad (3.20)$$

Denominator could be rewrite as expression 3.21.

$$1 + 2\zeta \frac{s}{\omega_n} + \frac{s^2}{\omega_n^2} \quad \left\{ \begin{array}{l} \omega_n = \sqrt{\frac{K_p K_v}{\tau_1}} \\ \zeta = \frac{1}{2} \left(\frac{1}{\omega_n \tau_1} + \omega_n \tau_2 \right) \end{array} \right. \quad (3.21)$$

The loop filter components (equation 3.22) can now be calculated independently for a given natural frequency f_n and damping factor ζ .

$$\left\{ \begin{array}{l} \tau_1 = \frac{K_p K_v}{\omega_n^2} \\ \tau_2 = \frac{2\zeta}{\omega_n} - \frac{1}{K_p K_v} \end{array} \right. \quad (3.22)$$

CHAPTER 4

MODULATION

4.1 Introduction

MODULATION is a technique used in electronic communication for transmitting information by using a higher frequency carrier such as a radio wave. This frequency transposition (Fig. 4.1) of the information signal (baseband signal) to a higher frequency band (radio frequency) allows to transmit it, through an electromagnetic medium. So, the carrier can be physically transmitted.

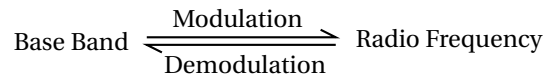

Figure 4.1: Modulation as a transposition frequency from baseband to radio frequency.

For communication between satellites and ground station, a carrier higher than some 10 MHz is required due to ionospheric opacity (figure 4.2). In radio communications or switched telephone network for instance, electrical signals can only be transferred over a limited passband frequency spectrum, with specific lower and upper cutoff frequencies (channel).

Modulation could have other application than electromagnetic transmission, for example for frequency division multiplexing*. There is also some cases where the modulation is used to down convert (at lower frequency) a use-full high frequency signal. This down conversion facilitates data-processing as sampling, filtering, de-

*Frequency division multiplexing is a technique by which the total bandwidth available in a communication medium is divided into a series of non-overlapping frequency sub-bands (channels), each of which is used to carry a separate signal.

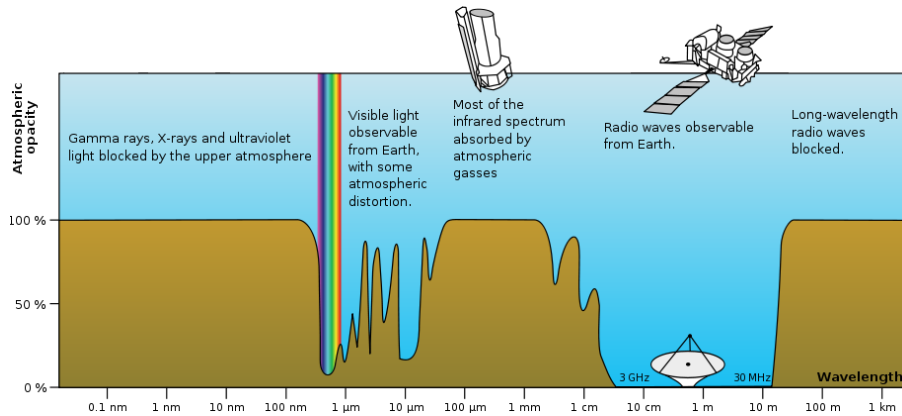

Figure 4.2: Radio atmospheric windows - from wikipedia

tection (*lock-in amplifier*^{*}) or amplification (*parametric amplifier*[†] ; *mixer*[‡]).

Lots of parameters can be varied to perform a modulation. In the case of simple sine wave (or square wave) carrier, there are three obvious parameters than can be varied :

- **Amplitude** ⇒ Amplitude modulation (or Amplitude-Shift Keying for digital modulation) - the amplitude of the carrier signal is varied in accordance to the instantaneous amplitude of the modulating signal.
 - Double-SideBand (DSB)
 - * DSB modulation with carrier - used on the AM radio broadcasting band
 - * DSB modulation with Suppressed-Carrier (DSB-SC) - used to reduce the power consumption
 - Single-SideBand (SSB)
 - * SSB modulation with carrier - one sideband suppressed to reduce occupied channel bandwidth
 - * SSB modulation with Suppressed-Carrier (SSB-SC) - to reduce both power and bandwidth

^{*}A lock-in amplifier is a type of amplifier that can extract a signal with a known carrier wave from an extremely noisy environment. It uses mixing, through a frequency mixer, to transpose the input signal to low-frequency.

[†]Parametric amplifier is a highly sensitive ultra-high-frequency or microwave amplifier having as its basic element a device whose reactance can be varied periodically by an alternating-current voltage at a pumping frequency.

[‡]A frequency mixer is a nonlinear electrical circuit that creates new frequency signals at the sum and difference of the original frequencies (as a multiplier).

- **Phase** \Rightarrow Phase modulation (or Phase-Shift Keying) - the phase shift of the carrier signal is varied in accordance to the instantaneous amplitude of the modulating signal.
- **Frequency** \Rightarrow Frequency modulation (or Frequency-Shift Keying) - the frequency of the carrier signal is varied in accordance to the instantaneous amplitude of the modulating signal.

4.2 Amplitude modulation

A continuous wave radio-frequency signal (a sinusoidal carrier wave) has its amplitude modulated by the input waveform before transmission. Input waveform modifies the amplitude of the carrier wave and determines the envelope of the waveform. A simple form of amplitude modulation, often used for digital communications, is *on-off keying**. This is used by radio amateurs to transmit Morse code.

Without transmission of the carrier, this modulation is obtained by simple multiplication of an input signal by carrier signal. Figure 4.3 shows wave form and spectrum of a multiplication of a sine wave input signal (f_s) by a sine wave carrier (f_0).

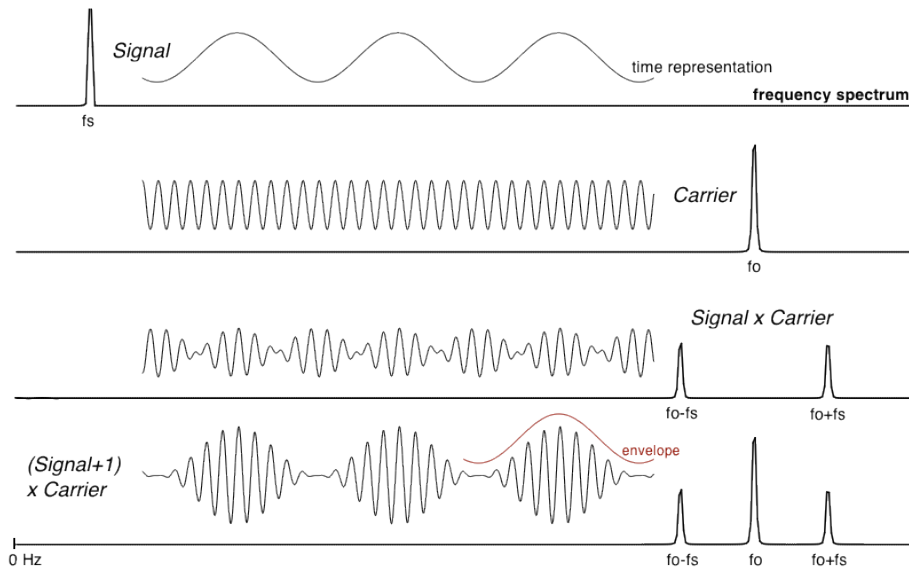

Figure 4.3: Time waveform and spectrum of a double side band amplitude modulation without ($S \times C$) and with ($S \times C + C$) transmission of the carrier.

Indeed, multiplication transposes the input signal S at either side of the C carrier frequency (frequency domain). Each sideband is equal in bandwidth to that of the

* a type of amplitude-shift keying in which binary data is represented by the presence or absence of a carrier.

modulating signal, and is a mirror image of the other. Moreover, for demodulation consideration, the carrier is generally added (see figure 4.4 and equation 4.1 with k a factor corresponding to the proportion of carrier added) to form a full amplitude modulation AM , with carrier transmission, as waveform illustrated at the end of the figure 4.3.

$$AM \equiv S \times C$$

$$AM \text{ with carrier suppressed} \equiv S \times C + \frac{C}{k} \quad (4.1)$$

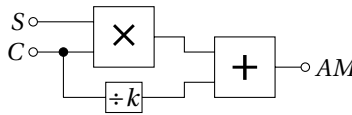

Figure 4.4: Scheme of amplitude modulator.

Most of the time, the carrier signal C is only a sine wave as expressed in equation 4.2.

$$C = C_0 \sin(2\pi f_0 t) \quad (4.2)$$

Input signal could also be expressed (Eq. 4.3) as a single tone signal for a simple example (Figures 4.3 and 4.5).

$$S = S_0 \sin(2\pi f_S t) \quad (4.3)$$

In these conditions, amplitude modulation is given by equation 4.4.

$$AM \equiv S_0 \sin(2\pi f_S t) \times C_0 \sin(2\pi f_0 t) + \frac{C_0}{k} \sin(2\pi f_0 t)$$

$$\equiv \underbrace{\frac{S_0 C_0}{2} [\cos(2\pi(f_0 - f_S)t) - \cos(2\pi(f_0 + f_S)t)]}_{\text{SideBands}} + \underbrace{\frac{C_0}{k} \sin(2\pi f_0 t)}_{\text{Carrier}} \quad (4.4)$$

Using trigonometric functions*, equation 4.4 clearly show that amplitude modulation produces, in addition to the adjacent sidebands $f_0 - f_S$ and $f_0 + f_S$, a signal with power concentrated at the carrier frequency f_0 . Amplitude modulation resulting in two sidebands and a carrier is called *double side band amplitude modulation*. This simplest kind of amplitude modulation is inefficient because of the large fraction of wasted power for transmission of the carrier and in the redundancy of information signal in the two sideband.

* $\sin(a) \sin(b) = \frac{\cos(a-b) - \cos(a+b)}{2}$

Increasing the efficiency : The carrier and/or one sideband may be suppressed at the expense of increased transmitter and receiver complexity. For reception, suppression of the carrier imply to restore it by the use of a local oscillator generated by a phase locked loop for example. Whereas in the case of carrier transmission, a simple rectifier diode could be used for demodulation (detection).

Suppressing both the carrier and one of the sidebands also improves bandwidth efficiency. This is single-sideband modulation, widely used in amateur radio and other low consumption communication applications.

4.2.1 Modulation index

The modulation index (also called "modulation depth") quantify the evolution of the carrier signal around its unmodulated level. It is defined differently in each modulation scheme. In the case of amplitude modulation, modulation index m is the ratio between the **input signal amplitude** S_0 and the **unmodulated transmitted carrier amplitude** $\frac{C_0}{k}$ (defined as expression 4.5).

$$m = \frac{kS_0}{C_0} \quad (4.5)$$

So if carrier amplitude varies by 50% above and below its unmodulated level, the modulation index is equal to 0.5. $k = m$ in the case of unity amplitude ($C_0 = S_0 = 1$). Figure 4.5 shows in time domain and frequency domain, the waveform of amplitude modulation for different modulation index.

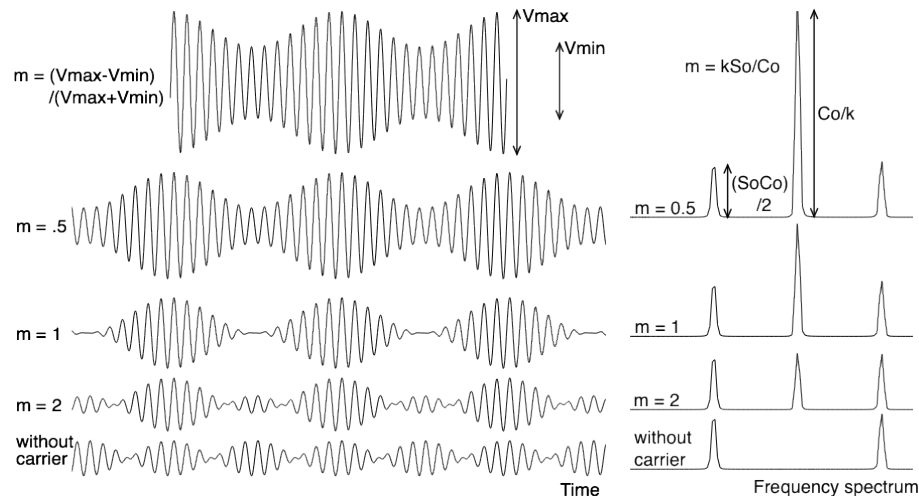

Figure 4.5: Different modulation index, from 50% ($m = 0.5$) to 200% ($m = 2$) and without carrier ($m = \infty$) in time domain and frequency domain.

On the spectrum representation, amplitude at each frequency can be easily obtained by using the equation 4.4. Techniques to graphically estimate the modulation

index are also reported on these two figures for $m \leq 1$.

Graphic estimation of the modulation index given by expression 4.6 is easy to use for $m \leq 1$. However, if $m > 1$, it could be more complicated to estimate V_{max} , V_{min} , and therefore m . In practice, the modulation index is generally comprised between 0 and 1.

$$m = \frac{V_{max} - V_{min}}{V_{max} + V_{min}} \quad \left\{ \begin{array}{l} \text{with } S_0 = \frac{V_{max} - V_{min}}{2} \\ \text{and } \frac{C_0}{k} = \frac{V_{max} + V_{min}}{2} \end{array} \right. \quad (4.6)$$

Indeed, if the modulation index is larger than 100 %, the input signal is distorted and could not be demodulated correctly. But a too small modulation index gives a large fraction of the power of the transmitted signal to the useless carrier signal alone.

4.3 Amplitude demodulation

Demodulation is used to recover the information content (S) from the modulated carrier wave. Demodulation is traditionally used in connection with radio receivers, but many other systems need demodulators.

There are two methods used to demodulate AM signals :

- Envelope detection
- Multiplication

4.3.1 Envelope demodulation

An amplitude modulated signal can be rectified without requiring a coherent* demodulator. For example, the signal can be passed through an envelope detector : a rectifier diode D and a low-pass RC filter as shown on figure 4.6. The output S' will follow the same curve as the input baseband signal S (Fig. 4.7). Only a DC *offset* (inversely proportional to the modulation index) remains and is easily removed by using a high pass filter (as a coupling capacitor). Note that the polarity of the diode does not matter.

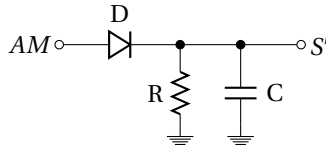

Figure 4.6: Scheme of a simple envelope demodulator.

*Coherence describes all properties of the correlation between physical quantities. In the case of amplitude demodulation, it referred to the need of use a local oscillator C' locked (synchronized) to the carrier C . As opposed to envelope demodulation which doesn't need local oscillator at all.

Rectifying can be modeled by an absolute value function : " $||$ " and Low Pass Filtering is noted " LPF ". So, envelope detection can be expressed as equation 4.7.

$$LPF \left[\left| S \times C + \frac{C}{k} \right| \right] = S' + cst \quad (4.7)$$

- **The rectifier** may be in the form of a single diode D, or anything that will pass current in one direction only*.
- **The filter** is usually a RC low-pass type when the difference in frequency between the signal and the carrier is very large[†]. Furthermore, the filter function can sometimes be achieved by relying on the limited frequency response of the circuitry following the rectifier.

However, **only amplitude modulation with a modulation index smaller than 100% can be demodulated by envelope detection**. Indeed, for a modulation index larger than 100%, or downright without carrier, envelope detection introduces necessarily large distortions. Figure 4.8 shows, for example, a rectifying detection of an amplitude modulation without carrier ($S \times C$). In this extreme cases where $m = \infty$, the demodulated signal is roughly a sine waves, but at twice (!) the frequency of the input signal.

☞ To avoid this kind of distortions, a coherent demodulation is required.

4.3.2 Product demodulation

The product detector, illustrated by figure 4.9, **multiplies** the incoming modulated signal AM by the signal of a local oscillator C' . C' need to have the **same frequency and phase as the carrier** C of the incoming signal[‡]. After low pass **filtering** (LPF) and suppression of the DC *offset*, the original signal will result as S' given by expression 4.8.

$$LPF \left[\left(S \times C + \frac{C}{k} \right) \times C' \right] = S' + cst \quad (4.8)$$

Using the same example as for modulation equation 4.4 and for $C' = C$, a product detection before the filtering could be expressed as equation 4.9. Using trigonometric functions[§], this expression shows that the information content S is restored in the base-band f_s , while the carrier and harmonics are pushed around $2f_0$ and are therefore easily filtered.

*Many natural substances exhibit rectifying behavior, which is why envelope demodulation was the earliest demodulation technique used in radio.

[†]In the case of AM radio broadcast, a carrier from few 100 kHz to few MHz is used for 10 kHz signal bandwidth (audio.). Regarding satellite communications, frequency carrier is of the order of several GHz; far away the signal bandwidth. For these kind of applications of the modulation, a simple first order low-pass filter is generally enough to attenuate residuals carrier harmonics.

[‡]If C' is in opposite-phase as compare to C , the demodulated signal is always = 0!

[§] $\sin(a) \cos(b) = \frac{\sin(a+b) + \sin(a-b)}{2}$; $\sin^2(a) = \frac{1 - \cos(2a)}{2}$; $\sin(-a) = -\sin(a)$

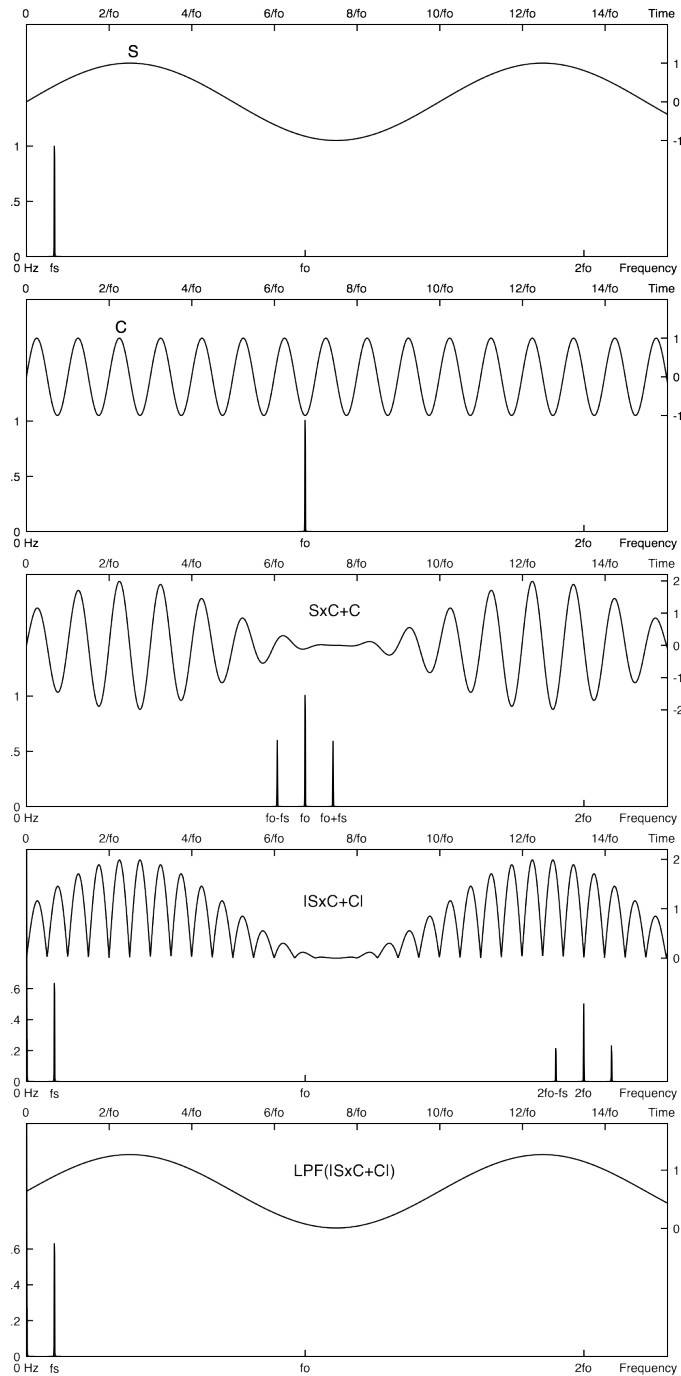

Figure 4.7: **Waveform of an envelope detection** : Signal S , Carrier C , AM with a unity modulation index $S \times C + C$, Rectifying as an absolute value $|S \times C + C|$ and low pass filtering $\text{LPF}(|S \times C + C|)$ for a complete reconstruction of the input signal S .

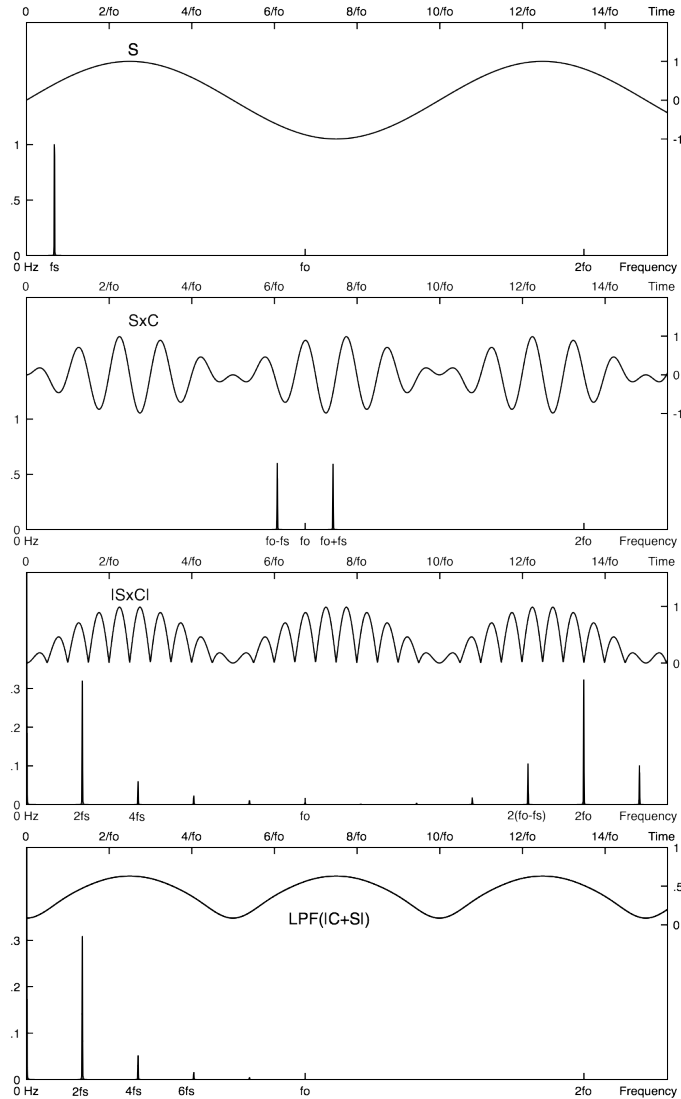

Figure 4.8: **Waveform of an envelope detection of an amplitude modulation without transmission of the carrier** : Signal S , AM without carrier $S \times C$, Rectifying as an absolute value $|S \times C|$ and low pass filtering $LPF(|S \times C|)$. This figure clearly shows distortions introduced by envelope detection in the case of modulation index larger than 100%. Signal resulting from envelope detection is at twice the frequency of the input signal. We also can see other harmonics $4f_s, 6f_s, \dots$ in the spectrum.

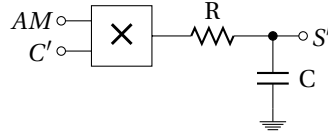

Figure 4.9: Simplified scheme of a product demodulator.

$$\begin{aligned}
 & C \times \left(S \times C + \frac{C}{k} \right) \\
 = & C_0 \sin(2\pi f_0 t) \left\{ \frac{S_0 C_0}{2} [\cos(2\pi(f_0 - f_s)t) - \cos(2\pi(f_0 + f_s)t)] + \frac{C_0}{k} \sin(2\pi f_0 t) \right\} \\
 = & \frac{S_0 C_0^2}{2} [\sin(2\pi f_0 t) \cos(2\pi(f_0 - f_s)t) - \sin(2\pi f_0 t) \cos(2\pi(f_0 + f_s)t)] \\
 & + \frac{C_0^2}{k} \sin^2(2\pi f_0 t) \\
 = & \frac{S_0 C_0^2}{4} [\sin(2\pi(2f_0 - f_s)t) + \sin(2\pi f_s t) - \sin(2\pi(2f_0 + f_s)t) + \sin(2\pi f_s t)] \\
 & + \frac{C_0^2}{2k} [1 - \cos(2\pi 2f_0 t)] \\
 = &
 \end{aligned}$$

$$\frac{S_0 C_0^2}{4} \left[\underbrace{2 \sin(2\pi f_s t)}_{\text{baseband}} + \underbrace{\sin(2\pi(2f_0 - f_s)t) - \sin(2\pi(2f_0 + f_s)t)}_{\text{radio frequency + DC} \rightarrow \text{filtered}} \right] + \frac{C_0^2}{2k} [1 - \cos(2\pi 2f_0 t)] \quad (4.9)$$

Figure 4.10 gives the waveform to illustrate this product detection in the particular case where $m = k = C_0 = S_0 = 1$. In this case, equation 4.9 can be simplified as equation 4.10. This last equation highlights the different spectral lines of the demodulated signal before filtering (DC, f_s , $2f_0 - f_s$, $2f_0$ and $2f_0 + f_s$).

$$\begin{aligned}
 & C \times (S \times C + C) \text{ with } C_0 \text{ and } S_0 = 1 \\
 = & \underbrace{\frac{1}{2}}_{DC} + \underbrace{\frac{1}{2} \sin(2\pi f_s t)}_{f_s} + \underbrace{\frac{1}{4} \sin(2\pi(2f_0 - f_s)t)}_{2f_0 - f_s} - \underbrace{\frac{1}{2} \cos(2\pi 2f_0 t)}_{2f_0} - \underbrace{\frac{1}{4} \sin(2\pi(2f_0 + f_s)t)}_{2f_0 + f_s} \\
 & \quad (4.10)
 \end{aligned}$$

The difference between envelope and product detection results on the lower number of harmonics introduced by coherent technique as compared to rectifying. Spectrum frequencies higher than $2f_0$ are shown in figure 4.11 for the two demodulation techniques. This comparison of the demodulated signal before filtering highlights harmonics at $4f_0$ introduced by rectifying.

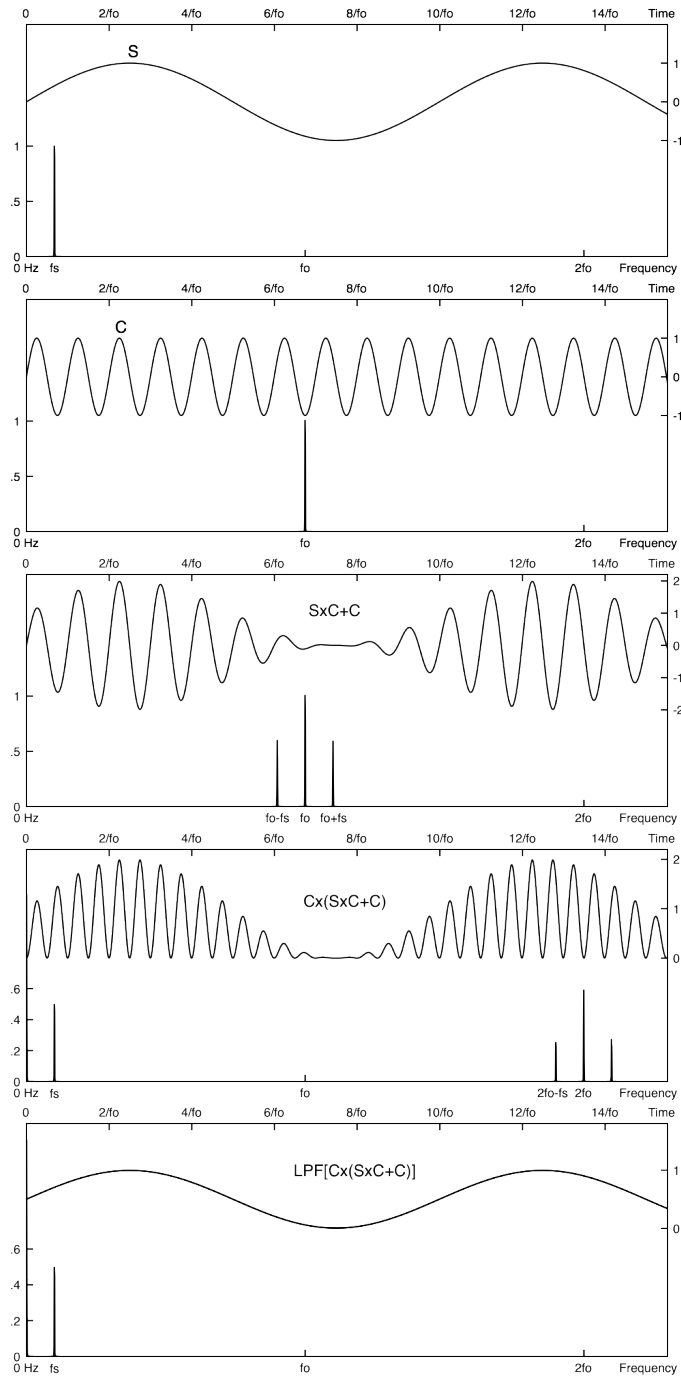

Figure 4.10: **Waveform of a product detection** : Signal S , Carrier C , AM signal $S \times C + C$, demodulation $C \times (S \times C + C)$ and low pass filtering $LPF[C \times (S \times C + C)]$.

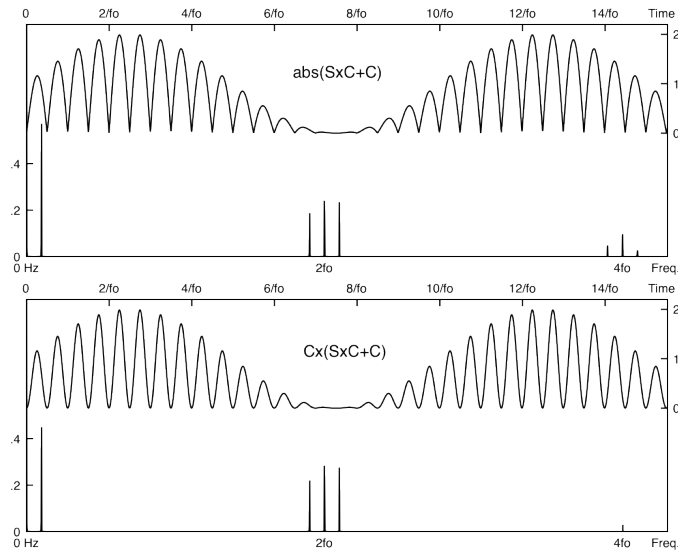

Figure 4.11: **Rectified vs Multiplied AM signal.** Rectifying introduce higher frequency harmonics. The difference is also visible on the bottom of the time frames.

But high frequency part of the spectrum can be easily filtered. Then the main difference between envelope and product detection is that the second technique can demodulate both amplitude modulation with or without carrier. So modulation without or with reduced carrier, *i.e.* with $m > 100\%$, requires necessarily (to avoid distortion as shown on figure 4.8) this kind of coherent demodulation. Figure 4.12 shows demodulation of a modulated signal without carrier ($S \times C$).

This product detection of a modulated signal without carrier can be expressed as equation 4.11. We see in this expressions, the baseband demodulated signal as the radio frequency signal that we need to filter. Finally, it appears that there is no DC on this demodulated signal. This is due to the absence of carrier.

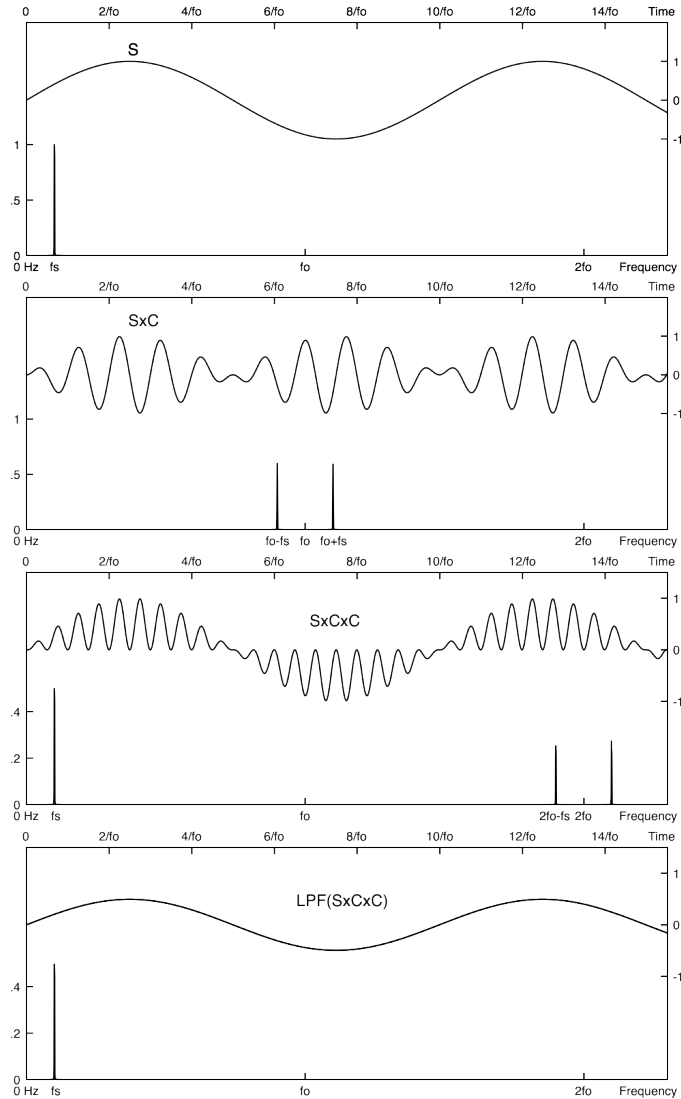

Figure 4.12: **Waveform of a product detection of an amplitude modulation without transmission of the carrier** : Signal S , AM without carrier $S \times C$, Demodulation by product $S \times S \times C$ and low pass filtering $LPF(S \times S \times C)$. With this product detection, there is no distortion, even if the carrier is not transmitted. Moreover, due to the fact that there is no carrier, there is no DC signal (*offset*) associated to the demodulated signal S' .

$C \times S \times C$

$$\begin{aligned} &= C_0 \sin(2\pi f_0 t) \frac{S_0 C_0}{2} [\cos(2\pi(f_0 - f_s)t) - \cos(2\pi(f_0 + f_s)t)] \\ &= \frac{S_0 C_0^2}{2} [\sin(2\pi f_0 t) \cos(2\pi(f_0 - f_s)t) - \sin(2\pi f_0 t) \cos(2\pi(f_0 + f_s)t)] \\ &= \frac{S_0 C_0^2}{4} [\sin(2\pi(2f_0 - f_s)t) + \sin(2\pi f_s t) - \sin(2\pi(2f_0 + f_s)t) + \sin(2\pi f_s t)] \\ &= \frac{S_0 C_0^2}{4} \left[\underbrace{2 \sin(2\pi f_s t)}_{\text{baseband}} + \underbrace{\sin(2\pi(2f_0 - f_s)t) - \sin(2\pi(2f_0 + f_s)t)}_{\text{radio frequency - filtered}} \right] \end{aligned} \tag{4.11}$$

APPENDIX A

POLYNOMIALS FILTER TABLES

Butterworth, Chebyshev (3 dB and 1 dB), Bessel and Legendre polynomials tables needed for filter synthesis :

n	Butterworth polynomials
2	$s^2 + 1.4142s + 1$
3	$(s + 1)(s^2 + s + 1)$
4	$(s^2 + 0.7654s + 1)(s^2 + 1.8478s + 1)$
5	$(s + 1)(s^2 + 0.618s + 1)(s^2 + 1.618s + 1)$
6	$(s^2 + 0.5176s + 1)(s^2 + 1.4142s + 1)(s^2 + 1.9319s + 1)$
7	$(s + 1)(s^2 + 0.445s + 1)(s^2 + 1.247s + 1)(s^2 + 1.8019s + 1)$
8	$(s^2 + 0.3902s + 1)(s^2 + 1.1111s + 1)(s^2 + 1.6629s + 1)(s^2 + 1.9616s + 1)$
9	$(s + 1)(s^2 + 0.3473s + 1)(s^2 + s + 1)(s^2 + 1.5321s + 1)(s^2 + 1.8794s + 1)$

n	Chebyshev polynomials (ripple 3dB $\equiv \epsilon = 1 \rightarrow H_{0_{even\ n}} = 2^{-0.5} \approx 0,707$)
2	$1.4125s^2 + 0.9109s + 1$
3	$(3.3487s + 1)(1.1916s^2 + 0.3559s + 1)$
4	$(5.1026s^2 + 2.0984s + 1)(1.1073s^2 + 0.1886s + 1)$
5	$(5.6328s + 1)(2.6525s^2 + 0.7619s + 1)(1.0683s^2 + 0.1172s + 1)$
6	$(11.2607s^2 + 3.2132s + 1)(1.9164s^2 + 0.4003s + 1)(1.0473s^2 + 0.0801s + 1)$
7	$(7.9061s + 1)(4.8959s^2 + 1.1159s + 1)(1.5942s^2 + 0.2515s + 1)(1.0347s^2 + 0.0582s + 1)$
8	$(19.8831s^2 + 4.3139s + 1)(3.1163s^2 + 0.5732s + 1)(1.4213s^2 + 0.1747s + 1)(1.0265s^2 + 0.0443s + 1)$
9	$(10.1756s + 1)(7.8967s^2 + 1.4585s + 1)(2.365s^2 + 0.3561s + 1)(1.3164s^2 + 0.1294s + 1)(1.0209s^2 + 0.0348s + 1)$

n	Chebyshev polynomials (ripple 1dB $\equiv \epsilon = 0.5 \rightarrow H_{0_{even n}} = \frac{1}{\sqrt{1+0.5^2}} \approx 0,894$)
2	$0.907s^2 + 0.9956s + 1$
3	$(2.023s + 1)(1.0058s^2 + 0.497s + 1)$
4	$(3.5791s^2 + 2.4113s + 1)(1.0136s^2 + 0.2828s + 1)$
5	$(3.454s + 1)(1.0118s^2 + 0.181s + 1)(2.3293s^2 + 1.0911s + 1)$
6	$(1.793s^2 + 0.6092s + 1)(1.0093s^2 + 0.1255s + 1)(8.0188s^2 + 3.7217s + 1)$
7	$(4.868s + 1)(1.0073s^2 + 0.092s + 1)(1.5303s^2 + 0.3919s + 1)(4.3393s^2 + 1.6061s + 1)$
8	$(1.0058s^2 + 0.0704s + 1)(2.9337s^2 + 0.8754s + 1)(1.382s^2 + 0.2755s + 1)(14.2326s^2 + 5.0098s + 1)$
9	$(6.276s + 1)(1.2896s^2 + 0.2054s + 1)(1.0047s^2 + 0.0556s + 1)(2.2801s^2 + 0.5566s + 1)(7.0242s^2 + 2.1033s + 1)$

n	Bessel polynomials
2	$0.618s^2 + 1.3616s + 1$
3	$(0.756s + 1)(0.4771s^2 + 0.9996s + 1)$
4	$(0.4889s^2 + 1.3396s + 1)(0.3889s^2 + 0.7742s + 1)$
5	$(0.665s + 1)(0.3245s^2 + 0.6215s + 1)(0.4128s^2 + 1.1401s + 1)$
6	$(0.2756s^2 + 0.513s + 1)(0.3504s^2 + 0.9686s + 1)(0.3887s^2 + 1.2217s + 1)$
7	$(0.593s + 1)(0.238s^2 + 0.4332s + 1)(0.301s^2 + 0.8303s + 1)(0.3394s^2 + 1.0944s + 1)$
8	$(0.2087s^2 + 0.3727s + 1)(0.2621s^2 + 0.7202s + 1)(0.2979s^2 + 0.9753s + 1)(0.3161s^2 + 1.1112s + 1)$
9	$(0.538s + 1)(0.231s^2 + 0.6319s + 1)(0.1854s^2 + 0.3257s + 1)(0.2635s^2 + 0.8710s + 1)(0.2834s^2 + 1.0243s + 1)$

n	Legendre polynomials
2	$s^2 + 1.4142s + 1$
3	$(1.612s + 1)(1.0744s^2 + 0.7417s + 1)$
4	$(1.0552s^2 + 0.4889s + 1)(2.3213s^2 + 2.5522s + 1)$
5	$(2.136s + 1)(1.0406s^2 + 0.3196s + 1)(2.0115s^2 + 1.5614s + 1)$
6	$(1.7155s^2 + 1.06s + 1)(1.0313s^2 + 0.2376s + 1)(3.9963s^2 + 3.508s + 1)$
7	$(2.617s + 1)(1.0241s^2 + 0.1765s + 1)(1.5102s^2 + 0.7171s + 1)(3.2679s^2 + 2.2825s + 1)$
8	$(1.3927s^2 + 0.5411s + 1)(1.0195s^2 + 0.1405s + 1)(5.9688s^2 + 4.3832s + 1)(2.6116s^2 + 1.5684s + 1)$
9	$(3.07s + 1)(1.3043s^2 + 0.4103s + 1)(2.1574s^2 + 1.0724s + 1)(1.0158s^2 + 0.1119s + 1)(4.7851s^2 + 2.9606s + 1)$

APPENDIX B

CD4046 DATA SHEET

CD4046BC Micropower Phase-Locked Loop

General Description

The CD4046BC micropower phase-locked loop (PLL) consists of a low power, linear, voltage-controlled oscillator (VCO), a source follower, a zener diode, and two phase comparators. The two phase comparators have a common signal input and a common comparator input. The signal input can be directly coupled for a large voltage signal, or capacitively coupled to the self-biasing amplifier at the signal input for a small voltage signal.

Phase comparator I, an exclusive OR gate, provides a digital error signal (phase comp. I Out) and maintains 90° phase shifts at the VCO center frequency. Between signal input and comparator input (both at 50% duty cycle), it may lock onto the signal input frequencies that are close to harmonics of the VCO center frequency.

Phase comparator II is an edge-controlled digital memory network. It provides a digital error signal (phase comp. II Out) and lock-in signal (phase pulses) to indicate a locked condition and maintains a 0° phase shift between signal input and comparator input.

The linear voltage-controlled oscillator (VCO) produces an output signal (VCO Out) whose frequency is determined by the voltage at the VCO_{IN} input, and the capacitor and resistors connected to pin C1_A, C1_B, R1 and R2.

The source follower output of the VCO_{IN} (demodulator Out) is used with an external resistor of 10 kΩ or more.

The INHIBIT input, when high, disables the VCO and source follower to minimize standby power consumption. The zener diode is provided for power supply regulation, if necessary.

Features

- Wide supply voltage range: 3.0V to 18V
- Low dynamic power consumption: 70 μW (typ.) at f_o = 10 kHz, V_{DD} = 5V
- VCO frequency: 1.3 MHz (typ.) at V_{DD} = 10V
- Low frequency drift: 0.06%/°C at V_{DD} = 10V with temperature
- High VCO linearity: 1% (typ.)

Applications

- FM demodulator and modulator
- Frequency synthesis and multiplication
- Frequency discrimination
- Data synchronization and conditioning
- Voltage-to-frequency conversion
- Tone decoding
- FSK modulation
- Motor speed control

Connection Diagram

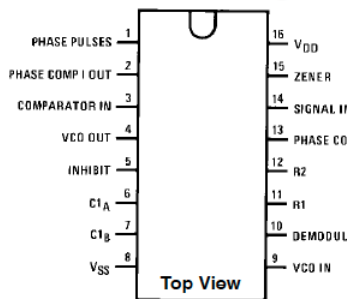

Block Diagram

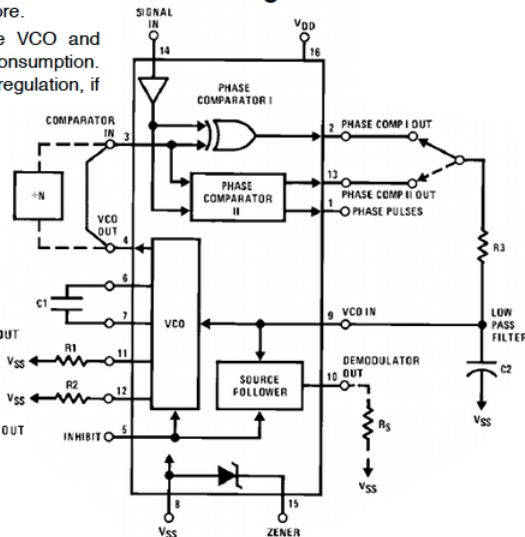

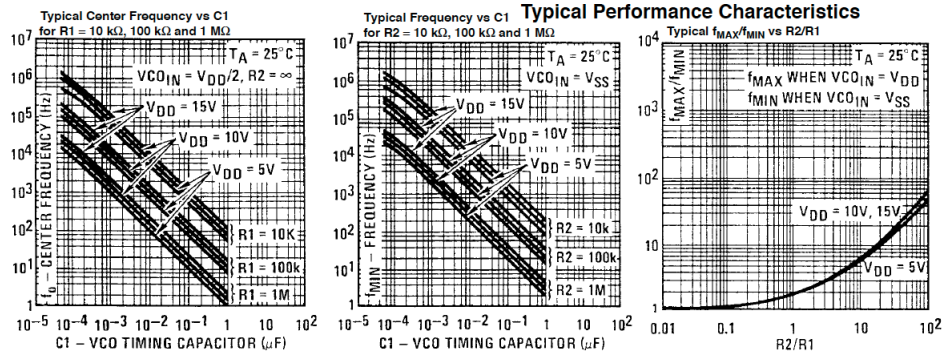

Typical Waveforms

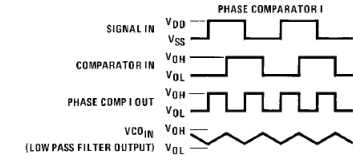

Typical Waveform Employing Phase Comparator I in Locked Condition

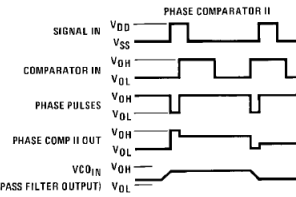

Typical Waveform Employing Phase Comparator II in Locked Condition

Characteristics	Using Phase Comparator I		Using Phase Comparator II	
	VCO Without Offset R2 = ∞	VCO With Offset	VCO Without Offset R2 = ∞	VCO With Offset
VCO Frequency				
For No Signal Input	VCO in PLL system will adjust to center frequency, f_0		VCO in PLL system will adjust to lowest operating frequency, f_{min}	
Frequency Lock Range, $2f_L$	$2f_L = \text{full VCO frequency range}$		$2f_L = f_{max} - f_{min}$	
Frequency Capture Range, $2f_C$			$2f_C = \frac{1}{\pi} \sqrt{\frac{\beta \pi^2 I_c}{71}}$	
Loop Filter Component Selection			For $2f_C$, see Ref.	
Phase Angle Between Single and Comparator	90° at center frequency (f_0), approximating 0° and 180° at ends of lock range ($2f_L$)		Always 0° in lock	
Locks on Harmonics of Center Frequency	Yes		No	
Signal Input Noise Rejection	High		Low	

Design Information

This information is a guide for approximating the value of. In addition to the given design information, refer to Figure 6 for external components for the CD4046B in a phase-locked loop system. The selected external components must be within the following ranges: R1, R2 ≥ 10 kΩ, R3 ≥ 10 kΩ, C1 ≥ 50 pF.

Characteristics	Using Phase Comparator I		Using Phase Comparator II	
	VCO Without Offset R2 = ∞	VCO With Offset	VCO Without Offset R2 = ∞	VCO With Offset
VCO Component Selection	Given: f_0 Use f_0 with Figure 5 to determine R1 and C1.	Given: f_0 and f_L Calculate f_{min} from the equation $f_{min} = f_0 - f_L$ Use f_{min} with Figure 6 to determine R2 and C1. Calculate f_{max} from the equation $f_{max} = f_0 + f_L$ Use f_{max} with Figure 7 to determine ratio R2/R1 to obtain R1.	Given: f_{min} Calculate f_0 from the equation $f_0 = \frac{f_{max}}{2}$ Use f_0 with Figure 5 to determine R1 and C1.	Given: f_{min} and f_{max} Use f_{min} with Figure 6 to determine R2 and C1. Calculate f_{max} from the equation $f_{max} = \frac{f_{min}}{2}$ Use f_{max} with Figure 7 to determine ratio R2/R1 to obtain R1.

LIST OF FIGURES

1.1 Transfer function of ideal filter : Fixed gain in the pass band and zero gain everywhere else ; transition at the cutoff frequency.	5
1.2 Passive low-pass filter : first order R-C, first order L-R and second order L-C.	6
1.3 Impedance bridge voltage divider.	6
1.4 Passive band-pass LCR filter.	8
1.5 Pole (✕) and zero (●) representation of the RLC filter (Fig. 1.4) into the s plane.	9
1.6 Stable if all poles are in the left hand s plane (<i>i.e.</i> have negative real parts).	9
1.7 Bode plot of the LCR band-pass filter figure 1.4.	10
1.8 Bode plot of a band-pass filter - $Q = 0.01 ; 0.1 ; 0.25 ; 0.5 ; 1 ; 2 ; 4 ; 10 ; 100$ (<i>i.e.</i> $\zeta = 50 ; 5 ; 2 ; 1 ; 0.5 ; 0.25 ; 0.125 ; 0.05 ; 0.005$).	11
1.9 Cascading filter stages for higher-order filters.	12
1.10 Pole locations of 1 st , 2 nd , 3 rd , 4 th and 5 th order Butterworth filter.	14
1.11 Bode plot of a second order Butterworth low pass filter.	22
1.12 H_0 the low frequency gain of a low-pass filter and H_∞ the high frequency gain of a high-pass filter.	22
1.13 Sallen-Key generic topology.	24
1.14 Sallen-Key low-pass filter.	24
1.15 Sallen-Key high-pass filter.	25
1.16 Cascading low and high pass filter for band-pass filtering.	25
1.17 Sallen-Key band-pass filter.	26
1.18 Voltage-controlled voltage-source (VCVS) filter topology band-pass filter.	26
1.19 Paralleling low and high pass filter for band-pass filtering.	27
1.20 Sallen-Key band-reject filter.	27
1.21 Filter amplitude response limits.	28
1.22 Steepness and phase linearity filter comparison.	29

1.23	Frequency response of a Butterworth, Chebyshev, Bessel and Legendre 5 th order low pass filter around cutoff frequency and far after it. Dashed line represent a f^{-5} slope for comparison to 5 th order filter rolloff.	31
1.24	Normalized ($f_0 = 1$) time response (step) of multipole (2 to 10) Butterworth, Chebyshev 1dB and Bessel filters.	31
1.25	Frequency response of a Butterworth low pass filter for n = 2 to 5. . . .	32
1.26	Frequency response of a Chebishev ($\epsilon = 1$) low pass filter for n = 2 to 5. . . .	33
1.27	Zoom in the passband of the frequency response of a Chebishev ($\epsilon = 1$) low pass filter for n = 4 and 5.	33
1.28	Frequency response of a Chebishev ($\epsilon = 0.5$) low pass filter for n = 2 to 5 order filter rolloff.	34
1.29	Zoom in the passband of the frequency response of a Chebishev ($\epsilon = 0.5$) low pass filter for n = 2 to 5.	34
1.30	Comparison between frequency response of two Chebishev low pass filters of 5 th order, one with a ripple factor of 1 dB, and the other with 3 dB.	35
1.31	Frequency response of a Bessel low pass filter for n = 2 to 5.	36
1.32	Comparison of the delay time as a function of frequency ($\frac{f}{f_c}$) between a Bessel, a Butterworth and a Chebishev low-pass filter (n=4).	36
1.33	Frequency response of a Legendre low pass filter for n = 2 to 5	36
1.34	Zoom on the passband of the frequency response of a Legendre low pass filter for n = 2 to 5.	37
1.35	Equivalence between Resistor and Switched Capacitor.	37
1.36	Equivalence between RC filter and switched capacitor filter.	37
2.1	DC/DC converter for space applications - CLYDE SPACE	39
2.2	<i>Buck</i> topology of a step-down DC/DC converter.	40
2.3	Simplified <i>Buck</i> converter circuit for the two configurations : left when the transistor T conducts (ON); right when it is OFF.	40
2.4	Voltages and current as a function of time for an ideal <i>buck</i> converter operating in continuous mode.	42
2.5	<i>Boost</i> topology of a step-up DC/DC converter.	42
2.6	<i>Buck-boost</i> Inverting topology of DC/DC converter. V_{out} is of the opposite polarity as V_{in}	43
2.7	<i>Flyback</i> topology of an isolated DC/DC converter.	44
2.8	Principle of a DC/DC converter feedback voltage regulation. D is the duty cycle of the switching transistor.	45
2.9	Voltage regulation of a <i>Buck</i> DC/DC converter by using Pulse Width Modulation (PWM).	45
2.10	Pulse Width Modulation (PWM).	46
3.1	PLLs used for space applications (Peregrine Semiconductor); GPS constellation around the Earth.	47
3.2	Block diagram of a PLL.	48
3.3	XOR phase comparator.	50

3.4	Periodic characteristic of an XOR phase comparator and a typical operating point. The slope K_p is the gain of the comparator.	51
3.5	VCO characteristic : V_{VCO} as a function of f_{VCO}	52
3.6	Scope of the 2 main frequency ranges of a PLL : Lock (or Hold) range and Capture range (more or less defines due to pull-in effect).	53
3.7	Hysteretic PLL characteristic.	54
3.8	Block diagram of PLL on phase domain.	55
3.9	One pole filter used as PLL loop filter.	55
3.10	One pole - one zero filter used as PLL loop filter.	56
3.11	Amplitude Bode plot of a one pole ($RC=t_0$) and a one pole - one zero ($(R_1 + R_2)C=t_1$ and $R_2C=t_2$) filter	57
4.1	Modulation as a transposition frequency from baseband to radio frequency.	58
4.2	Radio atmospheric windows - from wikipedia	59
4.3	Time waveform and spectrum of a double side band amplitude modulation without ($S \times C$) and with ($S \times C + C$) transmission of the carrier.	60
4.4	Scheme of amplitude modulator.	61
4.5	Different modulation index, from 50% ($m = 0.5$) to 200% ($m = 2$) and without carrier ($m = \infty$) in time domain and frequency domain.	62
4.6	Scheme of a simple envelope demodulator.	63
4.7	Waveform of an envelope detection : Signal S, Carrier C, AM with a unity modulation index $S \times C + C$, Rectifying as an absolute value $ S \times C + C $ and low pass filtering LPF($ S \times C + C $) for a complete reconstruction of the input signal S.	65
4.8	Waveform of an envelope detection of an amplitude modulation without transmission of the carrier : Signal S, AM without carrier $S \times C$, Rectifying as an absolute value $ S \times C $ and low pass filtering LPF($ S \times C $). This figure clearly shows distortions introduced by envelope detection in the case of modulation index larger than 100%. Signal resulting from envelope detection is at twice the frequency of the input signal. We also can see other harmonics $4f_s, 6f_s, \dots$ in the spectrum.	66
4.9	Simplified scheme of a product demodulator.	67
4.10	Waveform of a product detection : Signal S, Carrier C, AM signal $S \times C + C$, demodulation $C \times (S \times C + C)$ and low pass filtering LPF[$C \times (S \times C + C)$].	68
4.11	Rectified vs Multiplied AM signal . Rectifying introduce higher frequency harmonics. The difference is also visible on the bottom of the time frames.	69
4.12	Waveform of a product detection of an amplitude modulation without transmission of the carrier : Signal S, AM without carrier $S \times C$, Demodulation by product $S \times S \times C$ and low pass filtering LPF($S \times S \times C$). With this product detection, there is no distortion, even if the carrier is not transmitted. Moreover, due to the fact that there is no carrier, there is no DC signal (<i>offset</i>) associated to the demodulated signal S'	70

LIST OF TABLES

1.1	Bessel conversion factor	16
1.2	Butterworth polynomials complex roots.	19
1.3	Butterworth polynomials coefficients c_x . $P_n = B_n = \sum_{x=0}^n c_x s^x = c_n s^n +$ $c_{n-1} s^{n-1} + \dots + c_1 s + c_0$	20
1.4	Butterworth polynomials quadratic factors.	20
1.5	Butterworth normalized cutoff frequency (Scaling Factor - SF) and quality factor (Q) for each stages.	21
1.6	Filter normalized transposition.	23
1.7	Butterworth, Chebyshev, Bessel and Legendre filter advantages/disadvantages.	29
1.8	Butterworth, Chebyshev, Bessel and Legendre filter comparison.	30
3.1	XOR truth table.	49