



HAL
open science

Introduction to Optimal Control

Thierry Miquel

► **To cite this version:**

Thierry Miquel. Introduction to Optimal Control. Master. Introduction to optimal control, ENAC, France. 2022, pp.188. hal-02987731v2

HAL Id: hal-02987731

<https://cel.hal.science/hal-02987731v2>

Submitted on 17 Oct 2022

HAL is a multi-disciplinary open access archive for the deposit and dissemination of scientific research documents, whether they are published or not. The documents may come from teaching and research institutions in France or abroad, or from public or private research centers.

L'archive ouverte pluridisciplinaire **HAL**, est destinée au dépôt et à la diffusion de documents scientifiques de niveau recherche, publiés ou non, émanant des établissements d'enseignement et de recherche français ou étrangers, des laboratoires publics ou privés.



Distributed under a Creative Commons Attribution - NonCommercial 4.0 International License

Introduction to Optimal Control

Lecture notes - Draft

Thierry Miquel
thierry.miquel@enac.fr

October 12, 2022

Introduction

The application of optimal control theory to the practical design of multivariable control systems started in the 1960s¹: in 1957 R. Bellman applied dynamic programming to the optimal control of discrete-time systems. His procedure resulted in nonlinear feedback schemes. By 1958, L.S. Pontryagin has developed the maximum principle relying on the calculus of variations developed by L. Euler (1707-1783). He solved the minimum-time problem, deriving in 1962 an on/off relay control law as an optimal control. In 1960 three major papers were published by R. Kalman and coworkers, working in the U.S. One of these publicized the vital work of Lyapunov (1857-1918) in the time-domain control of nonlinear systems. The next discussed the optimal control of systems, providing the design equations for the Linear Quadratic Regulator (LQR). The third paper has provided the design equations for the discrete Kalman filter. The continuous Kalman filter was developed by Kalman and Bucy in 1961.

In control theory, Kalman introduced linear algebra and matrices, so that systems with multiple inputs and outputs could easily be treated. He also formalized the notion of optimality in control theory by minimizing a very general quadratic generalized energy function. In the period of a year, the major limitations of classical control theory were overcome, important new theoretical tools were introduced, and a new era in control theory had begun; we call it the era of modern control. In the period since 1980 the theory has been further refined under the name of H_2 theory which is out of the scope of this survey.

This lecture focuses on LQ (linear quadratic) theory and is a compilation of a number of results in the context of control system design. This has been written thanks to the references put in bibliographical section. It starts with a reminder of the main results in optimization of non linear systems which will be used as a background for this lecture. Then linear quadratic regulator (LQR) for finite final time and for infinite final time where the solution to the LQ problem are discussed. The robustness properties of the linear quadratic regulator (LQR) are then presented where the asymptotic properties and the guaranteed gain and phase margins associated with the LQ solution are presented. The next section presents some design methods with a special emphasis on symmetric root locus. We conclude with a short section dedicated to the Linear Quadratic Tracker (LQT) where the usefulness of augmenting the plant with integrators is presented.

¹<https://lewisgroup.uta.edu/history.htm>

Bibliography

- [1] *Alazard D., Apkarian P. and Cumer C., Robustesse et commande optimale*, Cépaduès (2000)
- [2] *Anderson B. and Moore J., Optimal Control: Linear Quadratic Methods*, Prentice Hall (1990)
- [3] *Friedland B., Control System Design: An Introduction to State-Space Methods*, Dover Books on Electrical Engineering (2012)
- [4] *Hespanha J. P., Linear Systems Theory*, Princeton University Press (2009)
- [5] *Hull D. G., Optimal Control Theory for Applications*, Springer (2003)
- [6] *Jeffrey B. Burl, Linear Optimal Control*, Prentice Hall (1998)
- [7] *Lewis F., Vrabie D. and Syrmos L., Optimal Control*, John Wiley & Sons (2012)
- [8] *Perry Y. Li, Linear Quadratic Optimal Control*, University of Minnesota (2012)
- [9] *Sinha A., Linear Systems: Optimal and Robust Control*, CRC Press (2007)
- [10] *Skogestad S., and Postlethwaite I., Multivariable Feedback Control: Analysis and Design*, John Wiley (2005)

Table of contents

1	Overview of Pontryagin's Minimum Principle	11
1.1	Introduction	11
1.2	Variation	11
1.3	Example	13
1.4	Lagrange multipliers	14
1.5	Example	15
1.6	Euler-Lagrange equation	17
1.7	Fundamentals of optimal control theory	20
1.7.1	Problem to be solved	20
1.7.2	Bolza, Mayer and Lagrange problems	20
1.7.3	First order necessary conditions	21
1.8	Example: brachistochrone problem	23
1.8.1	Problem overview	23
1.8.2	System dynamics	23
1.8.3	Euler-Lagrange approach	25
1.8.4	Hamiltonian approach	26
1.9	Hamilton-Jacobi-Bellman (HJB) equation	28
1.9.1	Finite horizon control	28
1.9.2	Principle of optimality, dynamic programming	29
1.9.3	Infinite horizon control	29
1.9.4	Application of HJB equation to linear time invariant systems	30
1.10	Pontryagin's principle	31
1.11	Hamiltonian over time	33
1.11.1	General result	33
1.11.2	Autonomous system without constraint on input	33
1.11.3	Free final time	34
1.12	Bang-bang control	35
1.12.1	Pontryagin's principle application	35
1.12.2	Example 1	37
1.12.3	Example 2	40
1.13	Singular arc - Legendre-Clebsch condition	42
2	Finite Horizon Linear Quadratic Regulator	43
2.1	Problem to be solved	43
2.2	Positive definite and positive semi-definite matrix	44
2.3	Hamiltonian matrix	45

2.4	Optimal control	46
2.4.1	State vector expression	46
2.4.2	Lagrange multipliers for imposed final state	47
2.4.3	Lagrange multipliers for weighted final state	47
2.4.4	Limit values when final state weighting matrix increases	48
2.4.5	Closed-loop block diagram	49
2.5	Riccati differential equation	50
2.6	Examples	51
2.6.1	Example 1	51
2.6.2	Example 2	52
2.7	Second order necessary condition for optimality	53
2.8	Minimum cost achieved	53
2.9	Application to minimum energy control problem	54
2.9.1	Moving a linear system close to a final state with minimum energy	54
2.9.2	Moving a linear system exactly to a final state with minimum energy	56
2.9.3	Example	57
2.10	Finite horizon LQ regulator with cross-term in the performance index	59
2.11	Extension to nonlinear system affine in control	61
3	Infinite Horizon Linear Quadratic Regulator (LQR)	63
3.1	Problem to be solved	63
3.2	Stabilizability and detectability	64
3.3	Algebraic Riccati equation	64
3.4	Extension to nonlinear system affine in control	66
3.5	Solving the algebraic Riccati equation	68
3.5.1	Hamiltonian matrix based solution	68
3.5.2	Proof of the results on the Hamiltonian matrix	69
3.5.3	Solving general algebraic Riccati and Lyapunov equations	70
3.6	Application to the optimal control of any scalar LTI plant	72
3.7	Hamiltonian matrix properties	74
3.8	Discrete time LQ regulator	77
3.8.1	Finite horizon LQ regulator	77
3.8.2	Finite horizon LQ regulator with zero terminal state	78
3.8.3	Infinite horizon LQ regulator	79
3.9	Robustness property	80
3.9.1	Hsu-Chen theorem	80
3.9.2	Generalized (MIMO) Nyquist stability criterion	83
3.9.3	Kalman equality	84
3.9.4	Robustness of Linear Quadratic Regulator	86
4	Design methods	91
4.1	Symmetric Root Locus	91
4.1.1	Characteristics polynomials	91
4.1.2	Root Locus reminder	92

4.1.3	Chang-Letov design procedure	94
4.1.4	Proof of the symmetric root locus result	96
4.2	Asymptotic properties of LQR applied to SISO plants	97
4.2.1	Closed-loop poles location	97
4.2.2	Shape of the magnitude of the loop gain	98
4.2.3	Weighting matrices selection	100
4.2.4	Poles assignment in optimal regulator using root locus	101
4.3	Poles shifting in optimal regulator	102
4.3.1	Mirror property	102
4.3.2	Reduced-order model	105
4.3.3	Shifting one real eigenvalue	105
4.3.4	Shifting a pair of complex conjugate eigenvalues	106
4.3.5	Sequential pole shifting via reduced-order models	107
4.4	Frequency domain approach	109
4.4.1	Non optimal pole assignment	109
4.4.2	Assignment of weighting matrices \mathbf{Q} and \mathbf{R}	110
4.5	Poles assignment in optimal regulator through matrix inequalities	113
4.6	Model matching	115
4.6.1	cross-term in the performance index	115
4.6.2	Implicit reference model	116
4.7	Optimal output feedback	117
4.7.1	Reformulation of the state feedback optimal control problem	117
4.7.2	Output feedback optimal control problem	120
4.7.3	Solution of the output feedback optimal control problem	121
4.7.4	Poles placement in a specified region	122
4.8	Frequency shaped LQ control	124
4.9	Optimal transient stabilization	126
5	Linear Quadratic Tracker (LQT)	129
5.1	Introduction	129
5.2	Control with feedforward	129
5.3	Finite horizon Linear Quadratic Tracker	130
5.4	Infinite horizon Linear Quadratic Tracker	133
5.4.1	General result	133
5.4.2	Asymptotically stable linear reference model	133
5.4.3	Constant reference tracking	134
5.5	Plant augmented with integrator	135
5.5.1	Integral augmentation	135
5.5.2	Proof of the cancellation of the steady-state error through integral augmentation	137
5.6	Tracking with prefilter	139
5.6.1	Tracking without integral augmentation	139
5.6.2	Tracking with integral augmentation	142

6	Linear Quadratic Gaussian (LQG) regulator	145
6.1	Introduction	145
6.2	Luenberger observer	146
6.3	White noise through Linear Time Invariant (LTI) system	147
6.3.1	Assumptions and definitions	147
6.3.2	Mean and covariance matrix of the state vector	148
6.3.3	Autocorrelation function of the stationary output vector	149
6.3.4	Proof of the expression of the autocorrelation function	153
6.4	Kalman-Bucy filter	154
6.4.1	Linear Quadratic Estimator	154
6.4.2	Sketch of the proof	156
6.5	Duality principle	157
6.6	Separation principle	158
6.7	Controller transfer function	160
6.8	Loop Transfer Recovery	162
6.8.1	Lack of guaranteed robustness of LQG design	162
6.8.2	Doyle's seminal example	162
6.8.3	Closed-loop eigenvalues and eigenvectors	164
6.8.4	Asymptotic behavior of Riccati equation	165
6.8.5	Loop Transfer Recovery (LTR) design	166
6.9	Proof of the Loop Transfer Recovery condition	169
6.9.1	Loop transfer function with observer	169
6.9.2	Loop Transfer Recovery (LTR) condition	171
6.9.3	Setting the Loop Transfer Recovery design parameter	173
6.10	Robust control design	174
6.11	Sensor data fusion	176
6.11.1	Complementary filter	176
6.11.2	Kalman filter	178
6.11.3	Relation between complementary filter and Kalman filter	179
6.12	Euler angles estimation	181
6.12.1	One dimensional attitude estimation	181
6.12.2	One dimensional complementary filter	182
6.12.3	Direct Cosine Matrix (DCM) and kinematic relations	184
6.12.4	Roll and pitch angles estimation from accelerometer measurements	185
6.12.5	Yaw angle estimation from magnetometer measurements	187
6.12.6	Angular velocity from gyroscope measurements	187
6.12.7	Attitude and Heading Reference System (AHRS) based on complementary filter	187

Chapter 1

Overview of Pontryagin's Minimum Principle

1.1 Introduction

Pontryagin's Minimum (or Maximum) Principle was formulated in 1956 by the Russian mathematician Lev Pontryagin (1908 - 1988) and his students¹. Its initial application was dedicated to the maximization of the terminal speed of a rocket. The result was derived using ideas from the classical calculus of variations.

This chapter is devoted to the main results of optimal control theory which leads to conditions for optimality.

1.2 Variation

Optimization can be accomplished by using a generalization of the differential called variation.

Let's consider the real scalar cost function $J(\underline{x})$ of a vector $\underline{x} \in \mathbb{R}^n$. Cost function $J(\underline{x})$ has a local minimum at \underline{x}^* if and only if for all $\delta\underline{x}$ sufficiently small;

$$J(\underline{x}^* + \delta\underline{x}) \geq J(\underline{x}^*) \quad (1.1)$$

An equivalent statement is that:

$$\Delta J(\underline{x}^*, \delta\underline{x}) = J(\underline{x}^* + \delta\underline{x}) - J(\underline{x}^*) \geq 0 \quad (1.2)$$

The term $\Delta J(\underline{x}^*, \delta\underline{x})$ is called the increment of $J(\underline{x})$. The optimality condition can be found by expanding $J(\underline{x}^* + \delta\underline{x})$ in a Taylor series around the extremum point \underline{x}^* . When $J(\underline{x})$ is a scalar function of multiple variables, the expansion of $J(\underline{x})$ in the Taylor series involves the gradient and the Hessian of the cost function $J(\underline{x})$:

- Assuming that $J(\underline{x})$ is a differentiable function, the term $\frac{dJ(\underline{x}^*)}{d\underline{x}}$ is the gradient of $J(\underline{x})$ at $\underline{x}^* \in \mathbb{R}^n$ which is the vector of \mathbb{R}^n defined by:

¹https://en.wikipedia.org/wiki/Pontryagin's_maximum_principle

$$\frac{dJ(\underline{x}^*)}{d\underline{x}} = \nabla J(\underline{x}^*) = \left[\begin{array}{c} \frac{dJ(\underline{x})}{dx_1} \\ \vdots \\ \frac{dJ(\underline{x})}{dx_n} \end{array} \right]_{\underline{x}=\underline{x}^*} \quad (1.3)$$

- Assuming that $J(\underline{x})$ is a twice differentiable function, the term $\frac{d^2 J(\underline{x}^*)}{d\underline{x}^2}$ is the Hessian of $J(\underline{x})$ at $\underline{x}^* \in \mathbb{R}^n$ which is the symmetric $n \times n$ matrix defined by:

$$\frac{d^2 J(\underline{x}^*)}{d\underline{x}^2} = \nabla^2 J(\underline{x}^*) = \left[\begin{array}{ccc} \frac{\partial^2 J(\underline{x})}{\partial x_1 \partial x_1} & \cdots & \frac{\partial^2 J(\underline{x})}{\partial x_1 \partial x_n} \\ \vdots & & \vdots \\ \frac{\partial^2 J(\underline{x})}{\partial x_n \partial x_1} & \cdots & \frac{\partial^2 J(\underline{x})}{\partial x_n \partial x_n} \end{array} \right]_{\underline{x}=\underline{x}^*} = \left[\frac{d^2 J(\underline{x}^*)}{dx_i dx_j} \right]_{1 \leq i, j \leq n} \quad (1.4)$$

Expanding $J(\underline{x}^* + \delta\underline{x})$ in a Taylor series around the point \underline{x}^* leads to the following expression, where *HOT* stands for *Higher-Order Terms*:

$$J(\underline{x}^* + \delta\underline{x}) = J(\underline{x}^*) + \delta\underline{x}^T \nabla J(\underline{x}^*) + \frac{1}{2} \delta\underline{x}^T \nabla^2 J(\underline{x}^*) \delta\underline{x} + HOT \quad (1.5)$$

Thus:

$$\begin{aligned} \Delta J(\underline{x}^*, \delta\underline{x}) &= J(\underline{x}^* + \delta\underline{x}) - J(\underline{x}^*) \\ &= \delta\underline{x}^T \nabla J(\underline{x}^*) + \frac{1}{2} \delta\underline{x}^T \nabla^2 J(\underline{x}^*) \delta\underline{x} + HOT \end{aligned} \quad (1.6)$$

When dealing with a functional (a real scalar function of functions) $\delta\underline{x}$ is called the variation of \underline{x} and the term in the increment $\Delta J(\underline{x}^*, \delta\underline{x})$ which is linear in $\delta\underline{x}^T$ is called the variation of J and is denoted $\delta J(\underline{x}^*)$. The variation of $J(\underline{x})$ is a generalization of the differential and can be applied to the optimization of a functional. Equation (1.6) can be used to develop necessary conditions for optimality. Indeed as $\delta\underline{x}$ approaches zero the terms $\delta\underline{x}^T \delta\underline{x}$ as well as *HOT* become arbitrarily small compared to $\delta\underline{x}$. As a consequence, *a necessary condition for \underline{x}^* to be a local extremum of the cost function J is that the first variation of J (its gradient) at \underline{x}^* is zero:*

$$\delta J(\underline{x}^*) = \nabla J(\underline{x}^*) = 0 \quad (1.7)$$

A critical (or stationary) point \underline{x}^* is a point where $\delta J(\underline{x}^*) = \nabla J(\underline{x}^*) = 0$. Furthermore the sign of the Hessian provides sufficient condition for a local extremum. Let's write the Hessian $\nabla^2 J(\underline{x}^*)$ at the critical point \underline{x}^* as follows:

$$\nabla^2 J(\underline{x}^*) = \left[\begin{array}{ccc} h_{11} & \cdots & h_{1n} \\ \vdots & & \vdots \\ h_{n1} & \cdots & h_{nn} \end{array} \right] \quad (1.8)$$

- The sufficient condition for the critical point \underline{x}^* to be a local minimum is that the Hessian is positive definite, that is that all the principal minor determinants are positive:

$$\Leftrightarrow \begin{cases} \forall 1 \leq k \leq n H_k > 0 \\ H_1 = h_{11} > 0 \\ H_2 = \begin{vmatrix} h_{11} & h_{12} \\ h_{21} & h_{22} \end{vmatrix} > 0 \\ H_3 = \begin{vmatrix} h_{11} & h_{12} & h_{13} \\ h_{21} & h_{22} & h_{23} \\ h_{31} & h_{32} & h_{33} \end{vmatrix} > 0 \\ \text{and so on...} \end{cases} \quad (1.9)$$

- The sufficient condition for the critical point \underline{x}^* to be a local maximum is that the Hessian is negative definite, or equivalently that the opposite of the Hessian is positive definite:

$$\Leftrightarrow \begin{cases} \forall 1 \leq k \leq n (-1)^k H_k > 0 \\ H_1 = h_{11} < 0 \\ H_2 = \begin{vmatrix} h_{11} & h_{12} \\ h_{21} & h_{22} \end{vmatrix} > 0 \\ H_3 = \begin{vmatrix} h_{11} & h_{12} & h_{13} \\ h_{21} & h_{22} & h_{23} \\ h_{31} & h_{32} & h_{33} \end{vmatrix} < 0 \\ \text{and so on...} \end{cases} \quad (1.10)$$

- If the Hessian has both positive and negative eigenvalues then the critical point \underline{x}^* is a saddle point for the cost function $J(\underline{x})$.

It should be emphasized that if the Hessian is positive semi-definite or negative semi-definite or has null eigenvalues at a critical point \underline{x}^* , then it cannot be concluded that the critical point is a minimizer or a maximizer or a saddle point of the cost function $J(\underline{x})$ and the test is inconclusive.

1.3 Example

Find the local maxima/minima for the following cost function:

$$J(\underline{x}) = 5 - (x_1 - 2)^2 - 2(x_2 - 1)^2 \quad (1.11)$$

First let's compute the first variation of J , or equivalently its gradient:

$$\frac{dJ(\underline{x})}{d\underline{x}} = \nabla J(\underline{x}) = \begin{bmatrix} \frac{dJ(\underline{x})}{dx_1} \\ \frac{dJ(\underline{x})}{dx_2} \end{bmatrix} = \begin{bmatrix} -2(x_1 - 2) \\ -4(x_2 - 1) \end{bmatrix} \quad (1.12)$$

A necessary condition for \underline{x}^* to be a local extremum is that the first variation of J at \underline{x}^* is zero for all $\delta\underline{x}$:

$$\delta J(\underline{x}^*) = \nabla J(\underline{x}^*) = 0 \quad (1.13)$$

As a consequence, the following point is a critical point:

$$\underline{x}^* = \begin{bmatrix} 2 \\ 1 \end{bmatrix} \quad (1.14)$$

Now, we compute the Hessian to conclude on the nature of this critical point:

$$\nabla^2 J(\underline{x}^*) = \begin{bmatrix} -2 & 0 \\ 0 & -4 \end{bmatrix} \quad (1.15)$$

As far as the Hessian is negative definite we conclude that the critical point \underline{x}^* is a local maximum.

1.4 Lagrange multipliers

Optimal control problems which will be tackled involve minimization of a cost function subject to constraints on the state vector and the control. The necessary condition given above is only applicable to unconstrained minimization problems; Lagrange multipliers provide a method of converting a constrained minimization problem into an unconstrained minimization problem of higher order. Optimization can then be performed using the above necessary condition. A constrained optimization problem is a problem of the form:

Maximize (or minimize) cost function $J(\underline{x})$ subject to the condition $g(\underline{x}) = 0$

The most popular technique to solve this constrained optimization problem is to use the Lagrange multiplier technique. Necessary condition for optimality of J at a point \underline{x}^* are that \underline{x}^* satisfies $g(\underline{x}) = 0$ and that the gradient of J is zero in all direction along the surface $g(\underline{x}) = 0$; this condition is satisfied if the gradient of J is normal to the surface at \underline{x}^* . As far as the gradient of $g(\underline{x})$ is normal to the surface, including \underline{x}^* , this condition is satisfied if the gradient of J is parallel (that is proportional) to the gradient of $g(\underline{x})$ at \underline{x}^* , or equivalently:

$$\left(\frac{\partial J(\underline{x})}{\partial \underline{x}} + \underline{\lambda}^T \frac{\partial g(\underline{x})}{\partial \underline{x}} \right) \Big|_{\underline{x}=\underline{x}^*} = 0 \quad (1.16)$$

It is worth noticing that the following relations hold:

$$\left\{ \begin{array}{l} J = a + \underline{b}^T \underline{x} = a + \underline{x}^T \underline{b} \Rightarrow \frac{\partial J}{\partial \underline{x}} = \begin{bmatrix} \frac{\partial J}{\partial x_1} \\ \frac{\partial J}{\partial x_2} \\ \vdots \\ \frac{\partial J}{\partial x_n} \end{bmatrix} = \underline{b} \\ J = a + \frac{\underline{b}^T \underline{x}}{\|\underline{x}\|^n} \Rightarrow \frac{\partial J}{\partial \underline{x}} = \begin{bmatrix} \frac{\partial J}{\partial x_1} \\ \frac{\partial J}{\partial x_2} \\ \vdots \\ \frac{\partial J}{\partial x_n} \end{bmatrix} = \frac{\underline{b}}{\|\underline{x}\|^n} - \frac{n}{\|\underline{x}\|^{n+2}} (\underline{x}^T \underline{b}) \underline{x} \end{array} \right. \quad (1.17)$$

As an illustration, consider the cost function $J(\underline{x}) = (x_1 - 1)^2 + (x_2 - 2)^2$: this is the equation of a circle of center $(1, 2)$ with radius $J(\underline{x})$. It is clear that $J(\underline{x})$ is minimal when (x_1, x_2) is situated on the center of the circle. In this case $J(\underline{x})^* = 0$. Nevertheless if we impose on (x_1, x_2) to belong to the straight line defined by $x_2 - 2x_1 - 6 = 0$ then $J(\underline{x})$ will be minimized as soon as the

circle of radius $J(\underline{x})$ tangent the straight line, that is if the gradient of $J(\underline{x})$ is normal to the surface at \underline{x}^* . Parameter $\underline{\lambda}$ is called the Lagrange multiplier and has the dimension of the number of constraints expressed through $g(\underline{x})$. The necessary condition for optimality can be obtained as the solution of the following unconstrained optimization problem where $L(\underline{x}, \underline{\lambda})$ is the Lagrange function:

$$L(\underline{x}, \underline{\lambda}) = J(\underline{x}) + \underline{\lambda}^T g(\underline{x}) \quad (1.18)$$

Setting to zero the gradient of the Lagrange function with respect to \underline{x} leads to (1.16) whereas setting to zero the derivative of the Lagrange function with respect to the Lagrange multiplier $\underline{\lambda}$ leads to the constraint $g(\underline{x}) = 0$. As a consequence, a necessary condition for \underline{x}^* to be a local extremum of the cost function J subject to the constraint $g(\underline{x}) = 0$ is that the first variation of Lagrange function (its gradient) at \underline{x}^* is zero:

$$\left. \frac{\partial L(\underline{x}, \underline{\lambda})}{\partial \underline{x}} \right|_{\underline{x}=\underline{x}^*} = 0 \Leftrightarrow \left(\frac{\partial J(\underline{x})}{\partial \underline{x}} + \underline{\lambda}^T \frac{\partial g(\underline{x})}{\partial \underline{x}} \right) \Big|_{\underline{x}=\underline{x}^*} = 0 \quad (1.19)$$

The bordered Hessian is the $(n+m) \times (n+m)$ symmetric matrix which is used for the second-derivative test. If there are m constraints represented by $g(\underline{x}) = 0$, then there are m border rows at the top-right and m border columns at the bottom-left (the transpose of the top-right matrix) and the zero in the south-east corner of the bordered Hessian is an $m \times m$ block of zeros, represented by $\mathbf{0}_{m \times m}$. The bordered Hessian $\mathbf{H}_b(p)$ is defined by:

$$\mathbf{H}_b(p) = \begin{bmatrix} \frac{\partial^2 L(\underline{x})}{\partial x_1 \partial x_1} - p & \frac{\partial^2 L(\underline{x})}{\partial x_1 \partial x_2} & \cdots & \frac{\partial^2 L(\underline{x})}{\partial x_1 \partial x_n} & \frac{\partial g_1(\underline{x})}{\partial x_1} & \cdots & \frac{\partial g_m(\underline{x})}{\partial x_1} \\ \frac{\partial^2 L(\underline{x})}{\partial x_2 \partial x_1} & \frac{\partial^2 L(\underline{x})}{\partial x_2 \partial x_2} - p & \cdots & \frac{\partial^2 L(\underline{x})}{\partial x_2 \partial x_n} & \frac{\partial g_1(\underline{x})}{\partial x_2} & \cdots & \frac{\partial g_m(\underline{x})}{\partial x_2} \\ \cdots & \cdots & \cdots & \cdots & \cdots & \cdots & \cdots \\ \frac{\partial^2 L(\underline{x})}{\partial x_n \partial x_1} & \frac{\partial^2 L(\underline{x})}{\partial x_n \partial x_2} & \cdots & \frac{\partial^2 L(\underline{x})}{\partial x_n \partial x_n} - p & \frac{\partial g_1(\underline{x})}{\partial x_n} & \cdots & \frac{\partial g_m(\underline{x})}{\partial x_n} \\ \frac{\partial g_1(\underline{x})}{\partial x_1} & \cdots & \cdots & \frac{\partial g_1(\underline{x})}{\partial x_n} & & & \\ \cdots & \cdots & \cdots & & & \mathbf{0}_{m \times m} & \\ \frac{\partial g_m(\underline{x})}{\partial x_1} & \cdots & \cdots & \frac{\partial g_m(\underline{x})}{\partial x_n} & & & \end{bmatrix} \Big|_{\underline{x}=\underline{x}^*} \quad (1.20)$$

The sufficient condition for the critical point \underline{x}^* to be an extrema is that the values of p obtained from $\det(\mathbf{H}_b(p)) = 0$ must be of the same sign.

- If all the values of p are strictly negative, then it is a maxima
- If all the values of p are strictly positive, then it is a minima
- However if some values of p are zero or of a different sign, then the critical point \underline{x}^* is a saddle point.

1.5 Example

Find the local maxima/minima for the following cost function:

$$J(\underline{x}) = x_1 + 3x_2 \quad (1.21)$$

Subject to the constraint:

$$g(\underline{x}) = x_1^2 + x_2^2 - 10 = 0 \quad (1.22)$$

First let's compute the Lagrange function of this problem:

$$L(\underline{x}, \lambda) = J(\underline{x}) + \lambda^T g(\underline{x}) = x_1 + 3x_2 + \lambda(x_1^2 + x_2^2 - 10) \quad (1.23)$$

A necessary condition for \underline{x}^* to be a local extremum is that the first variation of J at \underline{x}^* is zero for all $\delta\underline{x}$:

$$\frac{\partial L(\underline{x}^*)}{\partial \underline{x}} = \begin{bmatrix} 1 + 2\lambda x_1 \\ 3 + 2\lambda x_2 \end{bmatrix} = 0 \text{ s.t. } x_1^2 + x_2^2 - 10 = 0 \quad (1.24)$$

As a consequence, the Lagrange multiplier λ shall be chosen as follows:

$$\begin{bmatrix} x_1 = -\frac{1}{2\lambda} \\ x_2 = -\frac{3}{2\lambda} \end{bmatrix} \Rightarrow x_1^2 + x_2^2 - 10 = \frac{1}{4\lambda^2} + \frac{9}{4\lambda^2} - 10 = 0 \Leftrightarrow 10 - 40\lambda^2 = 0 \Leftrightarrow \lambda = \pm \frac{1}{2} \quad (1.25)$$

Using the values of the Lagrange multiplier within (1.24) we then obtain 2 critical points:

$$\lambda = \frac{1}{2} \Rightarrow x_1^* = \begin{bmatrix} -1 \\ -3 \end{bmatrix} \text{ and } \lambda = -\frac{1}{2} \Rightarrow x_2^* = \begin{bmatrix} 1 \\ 3 \end{bmatrix} \quad (1.26)$$

– For $\lambda = \frac{1}{2}$ the bordered Hessian is:

$$\mathbf{H}_b(p) = \begin{bmatrix} 2\lambda - p & 0 & 2x_1 \\ 0 & 2\lambda - p & 2x_2 \\ 2x_1 & 2x_2 & 0 \end{bmatrix}_{\underline{x}=\underline{x}^*} = \begin{bmatrix} 1 - p & 0 & -2 \\ 0 & 1 - p & -6 \\ -2 & -6 & 0 \end{bmatrix} \quad (1.27)$$

Thus:

$$\det(\mathbf{H}_b(p)) = -40 + 40p \quad (1.28)$$

We conclude that the critical point $(-1; -3)$ is a local minima because $\det(\mathbf{H}_b(p)) = 0$ for $p = +1$ which is strictly positive.

– For $\lambda = -\frac{1}{2}$ the bordered Hessian is:

$$\mathbf{H}_b(p) = \begin{bmatrix} 2\lambda - p & 0 & 2x_1 \\ 0 & 2\lambda - p & 2x_2 \\ 2x_1 & 2x_2 & 0 \end{bmatrix}_{\underline{x}=\underline{x}^*} = \begin{bmatrix} -1 - p & 0 & 2 \\ 0 & -1 - p & 6 \\ 2 & 6 & 0 \end{bmatrix} \quad (1.29)$$

Thus:

$$\det(\mathbf{H}_b(p)) = 40 + 40p \quad (1.30)$$

We conclude that the critical point $(+1; +3)$ is a local maxima because $\det(\mathbf{H}_b(p)) = 0$ for $p = -1$ which is strictly negative.

1.6 Euler-Lagrange equation

Historically, Euler-Lagrange equation came with the study of the tautochrone (or isochrone curve) problem. Lagrange solved this problem in 1755 and sent the solution to Euler. Their correspondence ultimately led to the calculus of variations ².

The problem considered was to find the expression of $\underline{x}(t)$ which minimizes the following performance index $J(\underline{x}(t))$ where $F(\underline{x}(t), \dot{\underline{x}}(t))$ is a real-valued twice continuous function:

$$J(\underline{x}(t)) = \int_0^{t_f} F(\underline{x}(t), \dot{\underline{x}}(t)) dt \quad (1.31)$$

Furthermore the initial and final values of $\underline{x}(t)$ are imposed:

$$\begin{cases} \underline{x}(0) = \underline{x}_0 \\ \underline{x}(t_f) = \underline{x}_f \end{cases} \quad (1.32)$$

Let $\underline{x}^*(t)$ be a candidate for the minimization of $J(\underline{x}(t))$. In order to see whether $\underline{x}^*(t)$ is indeed an optimal solution, this candidate optimal input is perturbed by a small amount $\delta\underline{x}$ which leads to a perturbation $\delta\underline{x}$ in the optimal state vector $\underline{x}^*(t)$:

$$\begin{cases} \underline{x}(t) = \underline{x}^*(t) + \delta\underline{x}(t) \\ \dot{\underline{x}}(t) = \dot{\underline{x}}^*(t) + \delta\dot{\underline{x}}(t) \end{cases} \quad (1.33)$$

The change δJ in the value of the performance index is obtained thanks to the calculus of variation:

$$\delta J = \int_0^{t_f} \delta F(\underline{x}(t), \dot{\underline{x}}(t)) dt = \int_0^{t_f} \left(\frac{\partial F^T}{\partial \underline{x}} \delta \underline{x} + \frac{\partial F^T}{\partial \dot{\underline{x}}} \delta \dot{\underline{x}} \right) dt \quad (1.34)$$

Integrating $\frac{\partial F^T}{\partial \dot{\underline{x}}} \delta \dot{\underline{x}}$ by parts leads to the following expression:

$$\begin{aligned} \frac{d}{dt} \left(\frac{\partial F^T}{\partial \dot{\underline{x}}} \delta \underline{x} \right) &= \frac{d}{dt} \frac{\partial F^T}{\partial \dot{\underline{x}}} \delta \underline{x} + \frac{\partial F^T}{\partial \dot{\underline{x}}} \delta \dot{\underline{x}} \\ \Rightarrow \delta J &= \int_0^{t_f} \left(\frac{\partial F^T}{\partial \underline{x}} \delta \underline{x} - \frac{d}{dt} \frac{\partial F^T}{\partial \dot{\underline{x}}} \delta \underline{x} \right) dt + \frac{\partial F^T}{\partial \dot{\underline{x}}} \delta \underline{x} \Big|_0^{t_f} \end{aligned} \quad (1.35)$$

Because $\delta\underline{x}$ is a perturbation around the optimal state vector $\underline{x}^*(t)$ we shall set to zero the first variation δJ whatever the value of the variation $\delta\underline{x}$:

$$\delta J = 0 \quad \forall \delta \underline{x} \quad (1.36)$$

This leads to the following necessary conditions for optimality:

$$\begin{cases} \frac{\partial F^T}{\partial \underline{x}} \delta \underline{x} - \frac{d}{dt} \frac{\partial F^T}{\partial \dot{\underline{x}}} \delta \underline{x} = 0 \\ \frac{\partial F^T}{\partial \dot{\underline{x}}} \delta \underline{x} \Big|_0^{t_f} = 0 \end{cases} \quad (1.37)$$

²https://en.wikipedia.org/wiki/Euler-Lagrange_equation

As far as the initial and final values of $\underline{x}(t)$ are imposed no variation are permitted on $\delta\underline{x}$:

$$\begin{cases} \underline{x}(0) = \underline{x}_0 \\ \underline{x}(t_f) = \underline{x}_f \end{cases} \Rightarrow \begin{cases} \delta\underline{x}(0) = 0 \\ \delta\underline{x}(t_f) = 0 \end{cases} \quad (1.38)$$

On the other hand it is worth noticing that if the final value was not imposed we shall have $\left. \frac{\partial F}{\partial \underline{x}} \right|_{t=t_f} = 0$.

Thus the first variation δJ of the functional cost reads:

$$\delta J = \int_0^{t_f} \left(\frac{\partial F^T}{\partial \underline{x}} \delta \underline{x} - \frac{d}{dt} \frac{\partial F^T}{\partial \dot{\underline{x}}} \delta \underline{x} \right) dt \quad (1.39)$$

In order to set to zero the first variation δJ whatever the value of the variation $\delta \underline{x}$ the following second-order partial differential equation has to be solved:

$$\frac{\partial F^T}{\partial \underline{x}} - \frac{d}{dt} \frac{\partial F^T}{\partial \dot{\underline{x}}} = 0 \quad (1.40)$$

Or by taking the transpose:

$$\frac{d}{dt} \frac{\partial F}{\partial \dot{\underline{x}}} - \frac{\partial F}{\partial \underline{x}} = 0 \quad (1.41)$$

We retrieve the well known Euler-Lagrange equation of classical mechanics.

Euler-Lagrange equation is a second order Ordinary Differential Equations (ODE) that \underline{x} shall satisfy to minimize $\int_0^{t_f} F(\underline{x}(t), \dot{\underline{x}}(t)) dt$. Euler-Lagrange equation is usually quite difficult to solve.

Nevertheless, because $F(\underline{x}(t), \dot{\underline{x}}(t))$ does not depends explicitly on time t , Beltrami identity³ provides a first integral of the Euler-Lagrange equation. Denoting by C a constant, the first integral of the Euler-Lagrange equation reads as follows:

$$\frac{d}{dt} \frac{\partial F}{\partial \dot{\underline{x}}} - \frac{\partial F}{\partial \underline{x}} = 0 \Leftrightarrow F - \frac{\partial F^T}{\partial \dot{\underline{x}}} \dot{\underline{x}} = C \quad (1.42)$$

Indeed, multiplying both sides of the Euler-Lagrange equation by $\dot{\underline{x}}^T$ we get:

$$\frac{d}{dt} \frac{\partial F}{\partial \dot{\underline{x}}} - \frac{\partial F}{\partial \underline{x}} = 0 \Rightarrow \dot{\underline{x}}^T \left(\frac{d}{dt} \frac{\partial F}{\partial \dot{\underline{x}}} \right) - \dot{\underline{x}}^T \frac{\partial F}{\partial \underline{x}} = 0 \quad (1.43)$$

Since $F(\underline{x}(t), \dot{\underline{x}}(t))$ does not depend explicitly on time t , we have:

$$\begin{aligned} \frac{dF(\underline{x}(t), \dot{\underline{x}}(t))}{dt} &= \frac{\partial F^T}{\partial \underline{x}} \frac{\partial \underline{x}}{\partial t} + \frac{\partial F^T}{\partial \dot{\underline{x}}} \frac{\partial \dot{\underline{x}}}{\partial t} \\ &= \dot{\underline{x}}^T \frac{\partial F}{\partial \underline{x}} + \frac{\partial F^T}{\partial \dot{\underline{x}}} \frac{\partial \dot{\underline{x}}}{\partial t} \\ \Rightarrow \dot{\underline{x}}^T \frac{\partial F}{\partial \underline{x}} &= \frac{dF}{dt} - \frac{\partial F^T}{\partial \dot{\underline{x}}} \frac{\partial \dot{\underline{x}}}{\partial t} \end{aligned} \quad (1.44)$$

Using this expression of $\dot{\underline{x}}^T \frac{\partial F}{\partial \underline{x}}$ in (1.43) reads:

$$\begin{aligned} \dot{\underline{x}}^T \left(\frac{d}{dt} \frac{\partial F}{\partial \dot{\underline{x}}} \right) - \left(\frac{dF}{dt} - \frac{\partial F^T}{\partial \dot{\underline{x}}} \frac{\partial \dot{\underline{x}}}{\partial t} \right) &= 0 \\ \Leftrightarrow \left(\frac{d}{dt} \frac{\partial F}{\partial \dot{\underline{x}}} \right)^T \dot{\underline{x}} + \frac{\partial F^T}{\partial \dot{\underline{x}}} \frac{\partial \dot{\underline{x}}}{\partial t} - \frac{dF}{dt} &= 0 \\ \Leftrightarrow \frac{d}{dt} \left(\frac{\partial F^T}{\partial \dot{\underline{x}}} \dot{\underline{x}} - F \right) &= 0 \end{aligned} \quad (1.45)$$

³https://en.wikipedia.org/wiki/Beltrami_identity

Denoting by C a constant, the first integral of the Euler-Lagrange equation finally reads as the Beltrami identity:

$$F - \frac{\partial F}{\partial \dot{x}} \dot{x} = C \quad (1.46)$$

Alternatively, Euler-Lagrange equation could be transformed into a set of first order Ordinary Differential Equations, which may be more convenient to manipulate, by introducing a control $\underline{u}(t)$ defined by $\dot{x}(t) = \underline{u}(t)$ and by using the Hamiltonian function \mathcal{H} as it will be seen in the next sections.

Example 1.1. *Let's find the shortest distance between two points $P_1 = (x_1, y_1)$ and $P_2 = (x_2, y_2)$ in the euclidean plane.*

The length of the path between the two points is defined by:

$$J(y(x)) = \int_{P_1}^{P_2} \sqrt{dx^2 + dy^2} = \int_{x_1}^{x_2} \sqrt{1 + (y'(x))^2} dx \quad (1.47)$$

For that example $F(y(x), y'(x))$ reads:

$$F(y(x), y'(x)) = \sqrt{1 + \left(\frac{dy(x)}{dx}\right)^2} = \sqrt{1 + (y'(x))^2} \quad (1.48)$$

The initial and final values on $y(x)$ are imposed as follows:

$$\begin{cases} y(x_1) = y_1 \\ y(x_2) = y_2 \end{cases} \quad (1.49)$$

The Euler-Lagrange equation for this example reads:

$$\frac{d}{dx} \frac{\partial F}{\partial y'} - \frac{\partial F}{\partial y} = 0 \Leftrightarrow \frac{d}{dx} \frac{y'(x)}{\sqrt{1 + (y'(x))^2}} = 0 \quad (1.50)$$

From the preceding relation it is clear that, denoting by c_1 a constant, $y'(x)$ shall satisfy the following first order differential equation:

$$\begin{aligned} \frac{y'(x)}{\sqrt{1 + (y'(x))^2}} = c_1 &\Rightarrow (y'(x))^2 = c_1^2 \left(1 + (y'(x))^2\right) \\ \Rightarrow (y'(x))^2 = \frac{c_1^2}{1 - c_1^2} &\Rightarrow y'(x) = a = \text{constant} \end{aligned} \quad (1.51)$$

Alternatively, Beltrami identity reads as follows:

$$\begin{cases} F(y, y') = \sqrt{1 + (y')^2} \\ F - \frac{\partial F}{\partial y'} y' = C \end{cases} \Rightarrow \begin{cases} \sqrt{1 + (y')^2} - \frac{(y')^2}{\sqrt{1 + (y')^2}} = C \\ \Rightarrow 1 = C \sqrt{1 + (y')^2} \\ \Rightarrow y'(x) = a = \text{constant} \end{cases} \quad (1.52)$$

Thus, the shortest distance between two fixed points in the euclidean plane is a curve with constant slope, that is a straight-line:

$$y(x) = ax + b \quad (1.53)$$

With initial and final values imposed on $y(x)$ we finally get for $y(x)$ the Lagrange polynomial of degree 1:

$$\begin{cases} y(x_1) = y_1 \\ y(x_2) = y_2 \end{cases} \Rightarrow y(x) = y_1 \frac{x - x_2}{x_1 - x_2} + y_2 \frac{x - x_1}{x_2 - x_1} \quad (1.54)$$

■

1.7 Fundamentals of optimal control theory

1.7.1 Problem to be solved

We first consider optimal control problems for general nonlinear *time invariant* systems of the form:

$$\begin{cases} \dot{\underline{x}} = f(\underline{x}, \underline{u}) \\ \underline{x}(0) = \underline{x}_0 \end{cases} \quad (1.55)$$

Where $\underline{x} \in \mathbb{R}^n$ and $\underline{u} \in \mathbb{R}^m$ are the state variable and control inputs, respectively, and $f(\underline{x}, \underline{u})$ is a continuous nonlinear function and \underline{x}_0 the initial conditions. The goal is to find a control \underline{u} that *minimizes* the following performance index:

$$J(\underline{u}(t)) = G(\underline{x}(t_f)) + \int_0^{t_f} F(\underline{x}(t), \underline{u}(t)) dt \quad (1.56)$$

Where:

- t is the current time and t_f the final time;
- $J(\underline{u}(t))$ is the integral cost function;
- $F(\underline{x}(t), \underline{u}(t))$ is the scalar running cost function;
- $G(\underline{x}(t_f))$ is the scalar terminal cost function.

Note that the state equation serves as constraints for the optimization of the performance index $J(\underline{u}(t))$. In addition, notice that the use of function $G(\underline{x}(t_f))$ is optional; indeed, if the final state $\underline{x}(t_f)$ is imposed then there is no need to insert the expression $G(\underline{x}(t_f))$ in the cost to be minimized.

1.7.2 Bolza, Mayer and Lagrange problems

The problem defined above is known as the Bolza problem. In the special case where $F(\underline{x}(t), \underline{u}(t)) = 0$ then the problem is known as the Mayer problem; on the other hand if $G(\underline{x}(t_f)) = 0$ the problem is known as the Lagrange problem.

The Bolza problem is equivalent to the Lagrange problem and in fact leads to it with the following change of variable:

$$\begin{cases} J_1(\underline{u}(t)) = \int_0^{t_f} (F(\underline{x}(t), \underline{u}(t)) + x_{n+1}(t)) dt \\ \dot{x}_{n+1}(t) = 0 \\ x_{n+1} = \frac{G(\underline{x}(t_f))}{t_f} \quad \forall t \end{cases} \quad (1.57)$$

It also leads to the Mayer problem if one sets:

$$\begin{cases} J_2(\underline{u}(t)) = G(\underline{x}(t_f)) + x_0(t_f) \\ \dot{\underline{x}}_0(t) = F(\underline{x}(t), \underline{u}(t)) \\ x_0(0) = 0 \end{cases} \quad (1.58)$$

1.7.3 First order necessary conditions

The optimal control problem is then a constrained optimization problem, with cost being a functional of $\underline{u}(t)$ and the state equation providing the constraint equations. This optimal control problem can be converted to an unconstrained optimization problem of higher dimension by the use of Lagrange multipliers. An augmented performance index is then constructed by adding a vector of Lagrange multipliers $\underline{\lambda}$ times each constraint imposed by the differential equations driving the dynamics of the plant; these constraints are added to the performance index by the addition of an integral to form the augmented performance index J_a :

$$J_a(\underline{u}(t)) = G(\underline{x}(t_f)) + \int_0^{t_f} (F(\underline{x}(t), \underline{u}(t)) + \underline{\lambda}^T(t)(f(\underline{x}, \underline{u}) - \dot{\underline{x}})) dt \quad (1.59)$$

Let $\underline{u}^*(t)$ be a candidate for the optimal input vector and let the corresponding state vector be $\underline{x}^*(t)$:

$$\dot{\underline{x}}^*(t) = f(\underline{x}^*(t), \underline{u}^*(t)) \quad (1.60)$$

In order to see whether $\underline{u}^*(t)$ is indeed an optimal solution, this candidate optimal input is perturbed by a small amount $\delta \underline{u}$ which leads to a perturbation $\delta \underline{x}$ in the optimal state vector $\underline{x}^*(t)$:

$$\begin{cases} \underline{u}(t) = \underline{u}^*(t) + \delta \underline{u}(t) \\ \underline{x}(t) = \underline{x}^*(t) + \delta \underline{x}(t) \end{cases} \quad (1.61)$$

Assuming that the final time t_f is known, the change δJ_a in the value of the augmented performance index is obtained thanks to the calculus of variation ⁴:

$$\begin{aligned} \delta J_a &= \frac{\partial G(\underline{x}(t_f))}{\partial \underline{x}(t_f)}^T \delta \underline{x}(t_f) + \\ &\quad \int_0^{t_f} \left(\frac{\partial F}{\partial \underline{x}}^T \delta \underline{x} + \frac{\partial F}{\partial \underline{u}}^T \delta \underline{u} + \underline{\lambda}^T(t) \left(\frac{\partial f}{\partial \underline{x}} \delta \underline{x} + \frac{\partial f}{\partial \underline{u}} \delta \underline{u} - \frac{d\delta \underline{x}}{dt} \right) \right) dt \\ &= \frac{\partial G(\underline{x}(t_f))}{\partial \underline{x}(t_f)}^T \delta \underline{x}(t_f) + \\ &\quad \int_0^{t_f} \left(\left(\frac{\partial F}{\partial \underline{x}}^T + \underline{\lambda}^T(t) \frac{\partial f}{\partial \underline{x}} \right) \delta \underline{x} + \left(\frac{\partial F}{\partial \underline{u}}^T + \underline{\lambda}^T(t) \frac{\partial f}{\partial \underline{u}} \right) \delta \underline{u} - \underline{\lambda}^T(t) \frac{d\delta \underline{x}}{dt} \right) dt \end{aligned} \quad (1.62)$$

In the preceding equation:

$$- \frac{\partial G(\underline{x}(t_f))}{\partial \underline{x}(t_f)}, \frac{\partial F}{\partial \underline{u}}^T \text{ and } \frac{\partial F}{\partial \underline{x}}^T \text{ are row vectors;}$$

⁴Ferguson J., Brief Survey of the History of the Calculus of Variations and its Applications (2004) arXiv:math/0402357

- $\frac{\partial f}{\partial \underline{x}}$ and $\frac{\partial f}{\partial \underline{u}}$ are matrices;
- $\frac{\partial f}{\partial \underline{x}} \delta \underline{x}$, $\frac{\partial f}{\partial \underline{u}} \delta \underline{u}$ and $\frac{d\delta \underline{x}}{dt}$ are column vectors.

Then we introduce the functional \mathcal{H} , known as the *Hamiltonian function*, which is defined as follows:

$$\boxed{\mathcal{H}(\underline{x}, \underline{u}, \underline{\lambda}) = F(\underline{x}, \underline{u}) + \underline{\lambda}^T(t) f(\underline{x}, \underline{u})} \quad (1.63)$$

Then:

$$\begin{cases} \frac{\partial \mathcal{H}^T}{\partial \underline{x}} = \frac{\partial F^T}{\partial \underline{x}} + \underline{\lambda}^T(t) \frac{\partial f}{\partial \underline{x}} \\ \frac{\partial \mathcal{H}^T}{\partial \underline{u}} = \frac{\partial F^T}{\partial \underline{u}} + \underline{\lambda}^T(t) \frac{\partial f}{\partial \underline{u}} \end{cases} \quad (1.64)$$

Equation (1.62) becomes:

$$\delta J_a = \frac{\partial G(\underline{x}(t_f))}{\partial \underline{x}(t_f)} \delta \underline{x}(t_f) + \int_0^{t_f} \left(\frac{\partial \mathcal{H}^T}{\partial \underline{x}} \delta \underline{x} + \frac{\partial \mathcal{H}^T}{\partial \underline{u}} \delta \underline{u} - \underline{\lambda}^T(t) \frac{d\delta \underline{x}}{dt} \right) dt \quad (1.65)$$

Let's concentrate on the last term within the integral that we integrate by parts:

$$\begin{aligned} \int_0^{t_f} \underline{\lambda}^T(t) \frac{d\delta \underline{x}}{dt} dt &= \underline{\lambda}^T(t) \delta \underline{x} \Big|_0^{t_f} - \int_0^{t_f} \dot{\underline{\lambda}}^T(t) \delta \underline{x} dt \\ \Leftrightarrow \int_0^{t_f} \underline{\lambda}^T(t) \frac{d\delta \underline{x}}{dt} dt &= \underline{\lambda}^T(t_f) \delta \underline{x}(t_f) - \underline{\lambda}^T(0) \delta \underline{x}(0) - \int_0^{t_f} \dot{\underline{\lambda}}^T(t) \delta \underline{x} dt \end{aligned} \quad (1.66)$$

As far as the initial state is imposed, the variation of the initial condition is null; consequently we have $\delta \underline{x}(0) = 0$ and:

$$\int_0^{t_f} \underline{\lambda}^T(t) \frac{d\delta \underline{x}}{dt} dt = \underline{\lambda}^T(t_f) \delta \underline{x}(t_f) - \int_0^{t_f} \dot{\underline{\lambda}}^T(t) \delta \underline{x} dt \quad (1.67)$$

Using (1.67) within (1.65) leads to the following expression for the first variation of the augmented functional cost:

$$\begin{aligned} \delta J_a &= \left(\frac{\partial G(\underline{x}(t_f))}{\partial \underline{x}(t_f)} - \underline{\lambda}^T(t_f) \right) \delta \underline{x}(t_f) + \\ &\int_0^{t_f} \left(\frac{\partial \mathcal{H}^T}{\partial \underline{u}} \delta \underline{u} + \left(\frac{\partial \mathcal{H}^T}{\partial \underline{x}} + \dot{\underline{\lambda}}^T(t) \right) \delta \underline{x} \right) dt \end{aligned} \quad (1.68)$$

In order to set the first variation of the augmented functional cost δJ_a to zero the time dependent Lagrange multipliers $\underline{\lambda}(t)$, which are also called costate functions, are chosen as follows:

$$\boxed{\dot{\underline{\lambda}}^T(t) + \frac{\partial \mathcal{H}^T}{\partial \underline{x}} = 0 \Leftrightarrow \dot{\underline{\lambda}}(t) = -\frac{\partial \mathcal{H}}{\partial \underline{x}}} \quad (1.69)$$

This equation is called the adjoint equation. As far as it is a differential equation we need to know the value of $\underline{\lambda}(t)$ at a specific value of time t to be able to compute its solution (also called its *trajectory*) :

- Assuming that final value $\underline{x}(t_f)$ is specified to be \underline{x}_f then the variation $\delta\underline{x}(t_f)$ in (1.68) is zero and $\underline{\lambda}(t_f)$ is set such that $\underline{x}(t_f) = \underline{x}_f$.
- Assuming that final value $\underline{x}(t_f)$ is *not* specified then the variation $\delta\underline{x}(t_f)$ in (1.68) is not equal to zero and the value of $\underline{\lambda}(t_f)$ is set by imposing that the following difference vanishes at final time t_f :

$$\boxed{\frac{\partial G(\underline{x}(t_f))^T}{\partial \underline{x}(t_f)} - \underline{\lambda}^T(t_f) = 0 \Leftrightarrow \underline{\lambda}(t_f) = \frac{\partial G(\underline{x}(t_f))}{\partial \underline{x}(t_f)}} \quad (1.70)$$

This is the boundary condition, also known as transversality condition, which set the final value of the Lagrange multipliers.

Hence in both situations the first variation of the augmented functional cost (1.68) can be written as:

$$\delta J_a = \int_0^{t_f} \left(\frac{\partial \mathcal{H}^T}{\partial \underline{u}} \delta \underline{u} \right) dt \quad (1.71)$$

Moreover if there is *no constraint on input* $\underline{u}(t)$, then $\delta \underline{u}$ is free and the first variation of the augmented functional cost δJ_a in (1.71) is set to zero through the following necessary condition for optimality:

$$\boxed{\delta J_a = 0 \Rightarrow \frac{\partial \mathcal{H}^T}{\partial \underline{u}} = 0 \Leftrightarrow \frac{\partial \mathcal{H}}{\partial \underline{u}} = 0} \quad (1.72)$$

1.8 Example: brachistochrone problem

1.8.1 Problem overview

A classic optimal control problem is the brachistochrone problem: it consists in computing the curve of fastest descent for a point of mass m which slides without friction and with constant gravitational acceleration g to a fixed end point in the shortest time⁵.

The control parameter is the slope $\gamma(t)$ of the curve. Variable $y(t)$ is the horizontal position of the point, $z(t)$ its vertical position in the down direction and $v(t)$ its velocity.

1.8.2 System dynamics

First let's focus on the dynamics of the system using Lagrangian Mechanics. Let \underline{q} be the vector of generalized coordinates. We choose:

$$\underline{q} := \begin{bmatrix} q_1(t) \\ q_2(t) \end{bmatrix} = \begin{bmatrix} y(t) \\ z(t) \end{bmatrix} \quad (1.73)$$

⁵<https://apmonitor.com/wiki/index.php/Apps/BrachistochroneProblem>

The kinetic energy $T(\underline{q}, \underline{\dot{q}})$ and potential energy $V(\underline{q})$ read as follows (remember that the vertical position is oriented downward):

$$\begin{cases} T(\underline{q}, \underline{\dot{q}}) = \frac{1}{2}m (\dot{y}(t)^2 + \dot{z}(t)^2) \\ V(\underline{q}) = -mgz(t) \end{cases} \quad (1.74)$$

The Lagrangian \mathcal{L} (for classical mechanics) is defined as the difference between kinetic and potential energy:

$$\mathcal{L} = T(\underline{q}, \underline{\dot{q}}) - V(\underline{q}) = \frac{1}{2}m (\dot{y}(t)^2 + \dot{z}(t)^2) + mgz(t) \quad (1.75)$$

The dynamics of the system is then obtained by applying Euler-Lagrange equation:

$$\frac{d}{dt} \left(\frac{\partial \mathcal{L}}{\partial \dot{q}_i} \right) - \frac{\partial \mathcal{L}}{\partial q_i} = 0 \Rightarrow \begin{cases} \ddot{y}(t) = 0 \\ \ddot{z}(t) = g \end{cases} \quad (1.76)$$

Now we introduce the following kinematic relations related to the velocity $v(t)$ of the point and to the slope $\gamma(t)$ of the curve on which the point slides on:

$$\begin{cases} \dot{y}(t) = v(t) \cos(\gamma(t)) \\ \dot{z}(t) = v(t) \sin(\gamma(t)) \end{cases} \quad (1.77)$$

When taking the time derivative of the square of the velocity $v(t)$ and using relations (1.76) we get the following expression of the time derivative of velocity $v(t)$:

$$\begin{aligned} v(t)^2 &= \dot{y}(t)^2 + \dot{z}(t)^2 \\ \Rightarrow v(t)\dot{v}(t) &= \dot{y}(t)\ddot{y}(t) + \dot{z}(t)\ddot{z}(t) \\ \Rightarrow \dot{v}(t) &= \frac{v(t) \sin(\gamma(t))g}{v(t)} \end{aligned} \quad (1.78)$$

Finally the dynamics of the system is of dimension 3 and reads as follows:

$$\begin{cases} \dot{y}(t) = v(t) \cos(\gamma(t)) \\ \dot{z}(t) = v(t) \sin(\gamma(t)) \\ \dot{v}(t) = g \sin(\gamma(t)) \end{cases} \quad (1.79)$$

In order to reduce the size of the system, it is worth noticing that $\dot{z}(t)$ and $\dot{v}(t)$ depend on $\sin(\gamma(t))$. So we can write:

$$\dot{v}(t) = g \frac{\dot{z}(t)}{v(t)} \Leftrightarrow v(t)\dot{v}(t) = g\dot{z}(t) \quad (1.80)$$

That is, after integration:

$$\begin{aligned} \frac{1}{2}v(t)^2 - \frac{1}{2}v(0)^2 &= g z(t) - g z(0) \\ \Leftrightarrow v(t) &= \sqrt{2g(z(t) - z(0)) + v(0)^2} \end{aligned} \quad (1.81)$$

Then the dynamics of the system is reduced to dimension 2:

$$\begin{cases} \dot{y}(t) = \cos(\gamma(t))\sqrt{2gz + l_0} \\ \dot{z}(t) = \sin(\gamma(t))\sqrt{2gz + l_0} \\ l_0 = v(0)^2 - 2gz(0) \end{cases} \quad (1.82)$$

Constant l_0 depends on initial conditions $v(0)$ and $z(0)$

The dynamics of the system is reduced one step further through the use of infinitesimal element of curvilinear abscissa ds . Indeed, on one side we have:

$$ds = \sqrt{dy^2 + dz^2} = \sqrt{1 + (z')^2} dy \quad (1.83)$$

where:

$$z' := \frac{dz}{dy} \quad (1.84)$$

On the other side, from (1.82) we have:

$$ds = \sqrt{dy^2 + dz^2} = \sqrt{y^2 + z^2} dt = \sqrt{2gz + l_0} dt \quad (1.85)$$

Thus by equating (1.83) and (1.85) we get the following relation between dy and dt :

$$\sqrt{2gz + l_0} dt = \sqrt{1 + (z')^2} dy \Rightarrow dt = \sqrt{\frac{1 + (z')^2}{2gz + l_0}} dy \quad (1.86)$$

Finally the system is reduced to dimension 1 through the following relation:

$$t' := \frac{dt}{dy} = \sqrt{\frac{1 + (z')^2}{2gz + l_0}} \quad (1.87)$$

1.8.3 Euler-Lagrange approach

Using Euler-Lagrange formalism, the optimal control problem can be formulated as follows:

$$\begin{aligned} & \text{find } z(y) \\ & \text{which minimizes } t_f = \int_0^{t_f} dt = \int_0^{y_f} F(z, z') dy \end{aligned} \quad (1.88)$$

According to (1.87) the functional $F(z, z')$ to be minimized reads:

$$F(z, z') = \sqrt{\frac{1 + (z')^2}{2gz + l_0}} \quad (1.89)$$

Then we have to find $z(y)$ which solves the Euler-Lagrange equation:

$$\frac{d}{dt} \frac{\partial F}{\partial \dot{x}} - \frac{\partial F}{\partial x} = 0 \quad (1.90)$$

Using Beltrami identity, the first integral of the Euler-Lagrange equation reads as follows where C is a constant:

$$F - \frac{\partial F}{\partial z'} z' = C \Leftrightarrow \sqrt{\frac{1 + (z')^2}{2gz + l_0}} - \frac{1}{\sqrt{2gz + l_0}} \frac{(z')^2}{\sqrt{1 + (z')^2}} = C \quad (1.91)$$

Multiplying both members by $\sqrt{(2gz + l_0)(1 + (z')^2)}$ and simplifying, we get:

$$C = \frac{1}{\sqrt{(2gz + l_0)(1 + (z')^2)}} \quad (1.92)$$

We thus obtain the following differential equation:

$$\begin{aligned} (2gz + l_0) \left(1 + (z')^2\right) &= \frac{1}{C^2} \\ \Leftrightarrow 2g \left(z + \frac{l_0}{2g}\right) \left(1 + (z')^2\right) &= \frac{1}{C^2} \end{aligned} \quad (1.93)$$

The following reduced height $z_r(t)$ is introduced in order to normalize the solution:

$$z_r := z + \frac{l_0}{2g} \Rightarrow dz_r = dz \quad (1.94)$$

We finally get:

$$z_r \left(1 + (z'_r)^2\right) = \frac{1}{2gC^2} \quad \text{where } z'_r = \frac{dz_r}{dy} \quad (1.95)$$

The solution of this differential equation is the cycloid curve. The parametric expression of the cycloid curve is the following where parameter θ varies from 0 to θ_f :

$$\begin{cases} y = R(C) (\theta - \sin(\theta)) \\ z_r = R(C) (1 - \cos(\theta)) \end{cases} \quad \text{where } R(C) := \frac{1}{4gC^2} \quad (1.96)$$

The cycloid curve corresponds to the trajectory of a point on a circle of radius $R(C)$ rolling along a straight line.

The values of C and θ_f shall then be chosen such that the final conditions on y and z_r are fulfilled:

$$\begin{cases} y(t_f) = R(C) (\theta_f - \sin(\theta_f)) \\ z_r(t_f) = R(C) (1 - \cos(\theta_f)) \end{cases} \quad (1.97)$$

1.8.4 Hamiltonian approach

We will use $z' := u$ as the control variable. The optimal control problem can be formulated as follows:

$$\begin{aligned} &\text{find } u(y) \\ &\text{which minimizes } J(u) = \int_0^{t_f} dt = \int_0^{y_f} \sqrt{\frac{1+u^2}{2gz(y)+l_0}} dy \\ &\text{under the following constraint :} \\ &z' = u \end{aligned} \quad (1.98)$$

The *Hamiltonian function* H reads:

$$H(\underline{x}, \underline{u}, \underline{\lambda}) = F(\underline{x}, \underline{u}) + \underline{\lambda}^T(t) f(\underline{x}, \underline{u}) = \sqrt{\frac{1+u^2}{2gz+l_0}} + \lambda_z u \quad (1.99)$$

Because there is no constraint on control u , the necessary conditions for optimality read as follows:

$$\begin{cases} \frac{\partial H}{\partial u} = 0 \\ \frac{\partial H}{\partial z} = -\lambda'_z \end{cases} \Rightarrow \begin{cases} \frac{1}{\sqrt{2gz+l_0}} \frac{u}{\sqrt{1+u^2}} + \lambda_z = 0 \\ -g\sqrt{1+u^2} (2gz+l_0)^{-3/2} = -\lambda'_z \end{cases} \quad (1.100)$$

Then we have to find the expression of control u as a function of z and λ_z and solve the differential equations involving z and λ_z :

$$\begin{cases} z' = u(z, \lambda_z) \\ \lambda'_z = g\sqrt{1+u(z, \lambda_z)^2} (2gz + l_0)^{-3/2} \end{cases} \quad (1.101)$$

This could be a tricky task but let's try it! First from the first equation of (1.100) we get the expression of $1+u^2$ as a function of z and λ_z :

$$\frac{u}{\sqrt{1+u^2}} = -\lambda_z \sqrt{2gz + l_0} \Rightarrow 1+u^2 = \frac{1}{1-\lambda_z^2(2gz + l_0)} \quad (1.102)$$

Using this expression in the second equation of (1.100), we get the following expression of λ'_z :

$$\begin{aligned} \lambda'_z &= g\sqrt{1+u^2} (2gz + l_0)^{-3/2} \\ &= g\sqrt{\frac{1}{1-\lambda_z^2(2gz+l_0)}} (2gz + l_0)^{-3/2} \end{aligned} \quad (1.103)$$

As far as the differential equation involving z is concerned, we use the expression of u^2 to get the following expression of $(z')^2$:

$$z' = u \Rightarrow (z')^2 = u^2 = \frac{1}{1-\lambda_z^2(2gz + l_0)} - 1 = \frac{\lambda_z^2(2gz + l_0)}{1-\lambda_z^2(2gz + l_0)} \quad (1.104)$$

From the first equation of (1.100), that is $\frac{1}{\sqrt{2gz+l_0}} \frac{u}{\sqrt{1+u^2}} + \lambda_z = 0$, it is clear that $u = z'$ and λ_z have opposite sign. Thus we get:

$$z' = -\lambda_z \sqrt{\frac{(2gz + l_0)}{1-\lambda_z^2(2gz + l_0)}} = -\lambda_z \sqrt{\frac{1}{1-\lambda_z^2(2gz + l_0)}} \sqrt{2gz + l_0} \quad (1.105)$$

Then we get the expression of $\sqrt{\frac{1}{1-\lambda_z^2(2gz+l_0)}}$ that we insert in (1.103). We get:

$$\begin{aligned} \sqrt{\frac{1}{1-\lambda_z^2(2gz+l_0)}} &= -\frac{z'}{\lambda_z \sqrt{2gz+l_0}} \\ \Rightarrow \lambda'_z &= -g \frac{z'}{\lambda_z \sqrt{2gz+l_0}} (2gz + l_0)^{-3/2} \\ &= -\frac{g}{\lambda_z} \frac{z'}{(2gz+l_0)^2} \end{aligned} \quad (1.106)$$

We finally get:

$$\lambda'_z \lambda_z = -\frac{g z'}{(2gz + l_0)^2} \quad (1.107)$$

Thus the first integral of this differential equation is the following where C_1 denotes a constant:

$$\lambda_z^2 = \frac{1}{2gz + l_0} + C_1 \quad (1.108)$$

Or, equivalently:

$$\lambda_z^2 (2gz + l_0) = 1 + C_1 (2gz + l_0) \quad (1.109)$$

Then this result is used in (1.102) to get the following relation:

$$\begin{aligned} 1 + u^2 &= \frac{1}{1 - \lambda_z^2 (2gz + l_0)} \\ &= \frac{1}{C_1 (2gz + l_0)} \\ \Rightarrow (2gz + l_0) (1 + u^2) &= -\frac{1}{C_1} \end{aligned} \quad (1.110)$$

Having in mind that $z' = u$, we retrieve the first integral (1.93) which has been obtained through Baltrami identity. Then the resolution process is similar to what has been done in the previous section.

1.9 Hamilton-Jacobi-Bellman (HJB) equation

1.9.1 Finite horizon control

Let $J^*(\underline{x}, t)$ be the optimal cost-to-go function between t and t_f :

$$J^*(\underline{x}, t) = \min_{\underline{u}(t) \in \mathcal{U}} \int_t^{t_f} F(\underline{x}(t), \underline{u}(t)) dt \quad (1.111)$$

The Hamilton-Jacobi-Bellman equation related to the optimal control problem (1.56) under the constraint (1.55) is the following first order partial derivative equation⁶:

$$\boxed{-\frac{\partial J^*(\underline{x}, t)}{\partial t} = \min_{\underline{u}(t) \in \mathcal{U}} \left(F(\underline{x}, \underline{u}) + \left(\frac{\partial J^*(\underline{x}, t)}{\partial \underline{x}} \right)^T f(\underline{x}, \underline{u}) \right)} \quad (1.112)$$

or, equivalently:

$$-\frac{\partial J^*(\underline{x}, t)}{\partial t} = \mathcal{H}^* \left(\frac{\partial J^*(\underline{x}, t)}{\partial \underline{x}}, \underline{x}(t) \right) \quad (1.113)$$

where

$$\mathcal{H}^*(\lambda(t), \underline{x}(t)) = \min_{\underline{u}(t) \in \mathcal{U}} \left(F(\underline{x}, \underline{u}) + \left(\frac{\partial J^*(\underline{x}, t)}{\partial \underline{x}} \right)^T f(\underline{x}, \underline{u}) \right) \quad (1.114)$$

For the time-dependent case, the terminal condition on the optimal cost-to-go function solution of (1.112) reads:

$$J^*(\underline{x}, t_f) = G(\underline{x}(t_f)) \quad (1.115)$$

It is worth noticing that the Lagrange multiplier $\lambda(t)$ represents the partial derivative with respect to the state of the optimal cost-to-go function⁷:

$$\boxed{\lambda(t) = \frac{\partial J^*(\underline{x}, t)}{\partial \underline{x}}} \quad (1.116)$$

⁶da Silva J., de Sousa J., Dynamic Programming Techniques for Feedback Control, Proceedings of the 18th World Congress, Milano (Italy) August 28 - September 2, 2011

⁷Alazard D., Optimal Control & Guidance: From Dynamic Programming to Pontryagin's Minimum Principle, lecture notes

1.9.2 Principle of optimality, dynamic programming

The preceding results lead to the so-called *dynamic programming* approach which has been introduced by Bellman⁸ in 1957. This is a very powerful approach which encompasses both necessary and sufficient conditions for optimality. Contrary to the Lagrange multipliers approach, the *dynamic programming* solves the constrained optimal problem directly. Behind the *dynamic programming* is the *principle of optimality*, which states that from any point on an optimal state space trajectory, the remaining trajectory is optimal for the corresponding problem initiated at that point. This result can be quite easily applied for discrete time system but for continuous time system it involves to find the solution of a partial derivative equation which may be difficult in practice.

1.9.3 Infinite horizon control

For *infinite horizon* control problem, the problem is to find the control $\underline{u}(t)$ which minimizes the following cost-to-go function:

$$J(\underline{x}) = \int_0^{\infty} F(\underline{x}(t), \underline{u}(t)) dt \quad (1.117)$$

under the following nonlinear *time invariant* dynamics of the form:

$$\begin{cases} \dot{\underline{x}} = f(\underline{x}, \underline{u}) \\ \underline{x}(0) = \underline{x}_0 \end{cases} \quad (1.118)$$

Then, denoting by $J^*(\underline{x})$ the optimal cost function (which now no more depends on time t), the Hamilton-Jacobi-Bellman equation related to this optimal control problem reads:

$$0 = \min_{\underline{u}(t) \in \mathcal{U}} \left(F(\underline{x}, \underline{u}) + \left(\frac{\partial J^*(\underline{x})}{\partial \underline{x}} \right)^T f(\underline{x}, \underline{u}) \right) \quad (1.119)$$

Lower bounds on the optimal cost are obtained by integrating the corresponding inequality:

$$0 \leq F(\underline{x}, \underline{u}) + \left(\frac{\partial J(\underline{x})}{\partial \underline{x}} \right)^T f(\underline{x}, \underline{u}) \quad \forall \underline{x}, \underline{u} \quad (1.120)$$

It is worth noticing that:

$$\begin{aligned} \int_0^{\infty} \left(\frac{\partial J(\underline{x})}{\partial \underline{x}} \right)^T f(\underline{x}, \underline{u}) dt &= \int_0^{\infty} \left(\frac{\partial J(\underline{x})}{\partial \underline{x}} \right)^T \dot{\underline{x}}(t) dt \\ &= \int_{\underline{x}(0)}^{\underline{x}(\infty)} \left(\frac{\partial J(\underline{x})}{\partial \underline{x}} \right)^T d\underline{x} \\ &= J(\underline{x}(\infty)) - J(\underline{x}(0)) \end{aligned} \quad (1.121)$$

Thus, assuming that $\underline{x}(\infty) = \underline{0}$, we get:

$$J(\underline{x}(0)) - J(\underline{0}) = - \int_0^{\infty} \left(\frac{\partial J(\underline{x})}{\partial \underline{x}} \right)^T f(\underline{x}, \underline{u}) dt \leq \int_0^{\infty} F(\underline{x}, \underline{u}) dt \quad (1.122)$$

⁸Bellman R., Dynamic programming, Princeton University Press, 1957

Moreover, the optimal cost $J^*(\underline{x})$ has a decay rate given by $-F(\underline{x}, \underline{u}^*)$, which is negative. Thus $J^*(\underline{x})$ may serve as a Lyapunov function to prove that the optimal control law is stabilizing⁹.

1.9.4 Application of HJB equation to linear time invariant systems

We consider in this section linear time invariant systems, where $\underline{x}(t)$ is the state vector and $\underline{u}(t)$ is the control vector of dimension m . Furthermore we assume that the cost-to-go function $J(\underline{x}, t)$ to be minimized is quadratic:

$$\begin{cases} \dot{\underline{x}}(t) = \mathbf{A}\underline{x}(t) + \mathbf{B}\underline{u}(t) \\ J(\underline{x}, t) = \int_t^{t_f} (\underline{x}^T(t)\mathbf{Q}\underline{x}(t) + \underline{u}^T(t)\mathbf{R}\underline{u}(t)) dt \end{cases} \quad (1.123)$$

where:

$$\begin{cases} \mathbf{Q} = \mathbf{Q}^T \geq 0 \\ \mathbf{R} = \mathbf{R}^T > 0 \end{cases} \quad (1.124)$$

Assuming that the final state at $t = t_f$ is set to zero, a candidate solution $J^*(\underline{x}, t)$ of the Hamilton-Jacobi-Bellman (HJB) partial differential equation is the following quadratic function:

$$J^*(\underline{x}, t) := \underline{x}^T \mathbf{P}(t) \underline{x} \text{ where } \mathbf{P}(t) = \mathbf{P}^T(t) \geq 0 \quad (1.125)$$

Thus:

$$\begin{cases} \frac{\partial J^*(\underline{x}, t)}{\partial t} = \underline{x}^T \dot{\mathbf{P}}(t) \underline{x} \\ \frac{\partial J^*(\underline{x}, t)}{\partial \underline{x}} = 2\mathbf{P}(t)\underline{x}(t) \end{cases} \quad (1.126)$$

Finally, assuming unconstrained control, that is $\underline{u}(t) \in \mathbb{R}^m$, the Hamilton-Jacobi-Bellman (HJB) equation (1.112) reads as follows:

$$\begin{aligned} -\underline{x}^T \dot{\mathbf{P}}(t) \underline{x} &= \min_{\underline{u}(t) \in \mathbb{R}^m} \left(F(\underline{x}, \underline{u}) + \left(\frac{\partial J^*(\underline{x})}{\partial \underline{x}} \right)^T f(\underline{x}, \underline{u}) \right) \\ &= \min_{\underline{u}(t) \in \mathbb{R}^m} \left(\underline{x}^T(t)\mathbf{Q}\underline{x}(t) + \underline{u}^T(t)\mathbf{R}\underline{u}(t) \right. \\ &\quad \left. + 2\underline{x}^T(t)\mathbf{P}(t)(\mathbf{A}\underline{x}(t) + \mathbf{B}\underline{u}(t)) \right) \end{aligned} \quad (1.127)$$

To get $\min_{\underline{u}(t) \in \mathbb{R}^m}$, we set the derivative of its argument with respect to \underline{u} to zero:

$$\begin{aligned} \frac{\partial}{\partial \underline{u}} (\underline{x}^T \mathbf{Q} \underline{x} + \underline{u}^T \mathbf{R} \underline{u} + 2\underline{x}^T \mathbf{P} (\mathbf{A} \underline{x} + \mathbf{B} \underline{u})) &= \underline{0} \\ \Rightarrow 2(\mathbf{R} \underline{u} + \mathbf{B}^T \mathbf{P} \underline{x}) &= \underline{0} \end{aligned} \quad (1.128)$$

We finally get:

$$\underline{u}(t) = -\mathbf{R}^{-1} \mathbf{B}^T \mathbf{P}(t) \underline{x}(t) \quad (1.129)$$

Thus the Hamilton-Jacobi-Bellman (HJB) partial differential equation reads:

$$-\underline{x}^T \dot{\mathbf{P}}(t) \underline{x} = \underline{x}^T \mathbf{Q} \underline{x} - \underline{x}^T \mathbf{P}(t) \mathbf{B} \mathbf{R}^{-1} \mathbf{B}^T \mathbf{P}(t) \underline{x} + 2\underline{x}^T \mathbf{P}(t) \mathbf{A} \underline{x} \quad (1.130)$$

⁹Anders Rantzer and Mikael Johansson, Piecewise Linear Quadratic Optimal Control, IEEE Transactions On Automatic Control, Vol. 45, No. 4, April 2000

Then, using the fact that $\mathbf{P}(t) = \mathbf{P}^T(t)$, we can write:

$$2\underline{x}^T \mathbf{P}(t) \mathbf{A} \underline{x} = 2\underline{x}^T \mathbf{A}^T \mathbf{P}(t) \underline{x} = \underline{x}^T (\mathbf{P}(t) \mathbf{A} + \mathbf{A}^T \mathbf{P}(t)) \underline{x} \quad (1.131)$$

Then the Hamilton-Jacobi-Bellman (HJB) partial differential equation becomes:

$$-\underline{x}^T \dot{\mathbf{P}}(t) \underline{x} = \underline{x}^T \mathbf{Q} \underline{x} - \underline{x}^T \mathbf{P}(t) \mathbf{B} \mathbf{R}^{-1} \mathbf{B}^T \mathbf{P}(t) \underline{x} + \underline{x}^T (\mathbf{P}(t) \mathbf{A} + \mathbf{A}^T \mathbf{P}(t)) \underline{x} \quad (1.132)$$

Because this equation must be true $\forall \underline{x}$, we conclude that $\mathbf{P}(t) = \mathbf{P}^T(t)$ shall solve the following differential Riccati differential equation:

$$-\dot{\mathbf{P}}(t) = \mathbf{A}^T \mathbf{P}(t) + \mathbf{P}(t) \mathbf{A} - \mathbf{P}(t) \mathbf{B} \mathbf{R}^{-1} \mathbf{B}^T \mathbf{P}(t) + \mathbf{Q} \quad (1.133)$$

For time invariant systems with infinite horizon ($t_f \rightarrow \infty$), the optimal cost-to-go function $J^*(\underline{x}, t)$ is independent of time t : $J^*(\underline{x}, t) = J^*(\underline{x})$. Thus matrix $\mathbf{P}(t)$ becomes a constant matrix:

$$t_f \rightarrow \infty \Rightarrow J^*(\underline{x}, t) = J^*(\underline{x}) \Rightarrow \mathbf{P}(t) = \mathbf{P} \quad (1.134)$$

1.10 Pontryagin's principle

In this section we consider the optimal control problem with possibly control-state constraints. More specifically we consider the problem of finding a control \underline{u} that *minimizes* the following performance index:

$$J(\underline{u}(t)) = G(\underline{x}(t_f)) + \int_0^{t_f} F(\underline{x}(t), \underline{u}(t)) dt \quad (1.135)$$

Under the following constraints:

– Dynamics and boundary conditions:

$$\begin{cases} \dot{\underline{x}} = f(\underline{x}, \underline{u}) \\ \underline{x}(0) = \underline{x}_0 \end{cases} \quad (1.136)$$

– Mixed control-state constraints:

$$c(\underline{x}, \underline{u}) \leq 0, \text{ where } c(\underline{x}, \underline{u}) : \mathbb{R}^n \times \mathbb{R}^m \rightarrow \mathbb{R} \quad (1.137)$$

Usually a slack variable $\alpha(t)$, which is actually a new control variable, is introduced in order to convert the preceding inequality constraint into an equality constraint:

$$c(\underline{x}, \underline{u}) + \alpha^2(t) = 0, \text{ where } \alpha(t) : \mathbb{R} \rightarrow \mathbb{R} \quad (1.138)$$

To solve this problem we introduce the *augmented Hamiltonian function* $\mathcal{H}_a(\underline{x}, \underline{u}, \underline{\lambda}, \underline{\mu})$ which is defined as follows¹⁰:

$$\begin{aligned} \mathcal{H}_a(\underline{x}, \underline{u}, \underline{\lambda}, \underline{\mu}, \alpha) &= \mathcal{H}(\underline{x}, \underline{u}, \underline{\lambda}) + \underline{\mu} (c(\underline{x}, \underline{u}) + \alpha^2) \\ &= F(\underline{x}, \underline{u}) + \underline{\lambda}^T(t) f(\underline{x}, \underline{u}) + \underline{\mu}(t) (c(\underline{x}, \underline{u}) + \alpha^2) \end{aligned} \quad (1.139)$$

Then the Pontryagin's principle states that the optimal control \underline{u}^* must satisfy the following conditions:

¹⁰Hull D. G., *Optimal Control Theory for Applications*, Springer (2003)

- Adjoint equation and transversality condition:

$$\begin{cases} \dot{\lambda}(t) = -\frac{\partial \mathcal{H}_a}{\partial \underline{x}} \\ \lambda(t_f) = \frac{\partial G(\underline{x}(t_f))}{\partial \underline{x}(t_f)} \end{cases} \quad (1.140)$$

- Local minimum condition for augmented Hamiltonian:

$$\begin{cases} \frac{\partial \mathcal{H}_a}{\partial \underline{u}} = 0 \\ \frac{\partial \mathcal{H}_a}{\partial \alpha} = 0 \Rightarrow 2\underline{\mu}\alpha = 0 \end{cases} \quad (1.141)$$

- Sign of multiplier $\underline{\mu}(t)$ and complementarity condition: the equation $\frac{\partial \mathcal{H}_a}{\partial \alpha} = 0$ implies $2\underline{\mu}\alpha = 0$. Thus either $\underline{\mu} = 0$, which is an off-boundary arc, or $\alpha = 0$ which is an on-boundary arc:

- For the off-boundary arc where $\underline{\mu} = 0$ control \underline{u} is obtained from $\frac{\partial \mathcal{H}_a}{\partial \underline{u}} = 0$ and α from the equality constraint $c(\underline{x}, \underline{u}) + \alpha^2 = 0$;

- For the on-boundary arc where $\alpha = 0$ control \underline{u} is obtained from equality constraint $c(\underline{x}, \underline{u}) = 0$. Indeed there always exists a smooth function $\underline{u}_b(\underline{x})$ called boundary control which satisfies:

$$c(\underline{x}, \underline{u}_b(\underline{x})) = 0 \quad (1.142)$$

Then multiplier $\underline{\mu}$ is obtained from $\frac{\partial \mathcal{H}_a}{\partial \underline{u}} = 0$:

$$0 = \frac{\partial \mathcal{H}_a}{\partial \underline{u}} = \frac{\partial \mathcal{H}}{\partial \underline{u}} + \underline{\mu} \frac{\partial c(\underline{x}, \underline{u})}{\partial \underline{u}} \Rightarrow \underline{\mu} = - \left. \frac{\frac{\partial \mathcal{H}_a}{\partial \underline{u}}}{\frac{\partial c(\underline{x}, \underline{u})}{\partial \underline{u}}} \right|_{\underline{u}=\underline{u}_b(\underline{x})} \quad (1.143)$$

Weierstrass conditions (proposed in 1879) for a variational extremum states that optimal control \underline{u}^* and α^* within the *augmented Hamiltonian function* \mathcal{H}_a must satisfy the following condition for a minimum at every point of the optimal path:

$$\mathcal{H}_a(\underline{x}^*, \underline{u}^*, \underline{\lambda}^*, \underline{\mu}^*, \alpha^*) - \mathcal{H}_a(\underline{x}^*, \underline{u}, \underline{\lambda}^*, \underline{\mu}^*, \alpha) < 0 \quad (1.144)$$

Since $c(\underline{x}, \underline{u}) + \alpha^2(t) = 0$, the Weierstrass conditions for a variational extremum can be rewritten as a function of the *Hamiltonian function* \mathcal{H} and the inequality constraint:

$$\begin{cases} \mathcal{H}(\underline{x}^*, \underline{u}^*, \underline{\lambda}^*) - \mathcal{H}(\underline{x}^*, \underline{u}, \underline{\lambda}^*) < 0 \\ c(\underline{x}^*, \underline{u}^*) \leq 0 \end{cases} \quad (1.145)$$

or, equivalently:

$$\boxed{\underline{u}^* = \min_{\underline{u}(t) \in \mathcal{U}} \mathcal{H}(\underline{x}^*, \underline{u}, \underline{\lambda}^*)} \quad (1.146)$$

where \mathcal{U} denotes the set of admissible values for the control \underline{u} (here $\underline{u}(t) \in \mathcal{U}$ as soon as $c(\underline{x}^*, \underline{u}) \leq 0$). The last relation is the so-called Pontryagin's principle.

1.11 Hamiltonian over time

1.11.1 General result

From Pontryagin's principle, special conditions for the Hamiltonian can be derived¹¹. When the final time t_f is fixed and the Hamiltonian \mathcal{H} does not depend explicitly on time, that is when $\frac{\partial \mathcal{H}}{\partial t} = 0$, then the Hamiltonian functional \mathcal{H} remains constant along an optimal trajectory:

$$\boxed{\mathcal{H}(\underline{x}^*, \underline{u}^*, \underline{\lambda}^*) = \text{constant}} \quad (1.147)$$

Moreover, if the terminal time t_f is free, then along the optimal trajectory we have:

$$\boxed{\mathcal{H}(\underline{x}^*, \underline{u}^*, \underline{\lambda}^*) = 0 \text{ when } t_f \text{ is free}} \quad (1.148)$$

1.11.2 Autonomous system without constraint on input

We will show that the Hamiltonian \mathcal{H} is constant along the optimal trajectory in the particular case of autonomous system assuming no constraint on input $\underline{u}(t)$. For an autonomous system, the function $f(\cdot)$ is not an explicit function of time. From (1.63) we get:

$$\frac{d\mathcal{H}}{dt} = \frac{\partial \mathcal{H}^T}{\partial \underline{x}} \frac{d\underline{x}}{dt} + \frac{\partial \mathcal{H}^T}{\partial \underline{u}} \frac{d\underline{u}}{dt} + \frac{\partial \mathcal{H}^T}{\partial \underline{\lambda}} \frac{d\underline{\lambda}}{dt} \quad (1.149)$$

According to (1.55), (1.63) and (1.69) we have

$$\begin{cases} \dot{\underline{\lambda}}^T(t) = -\frac{\partial \mathcal{H}^T}{\partial \underline{x}} \\ \frac{\partial \mathcal{H}^T}{\partial \underline{\lambda}} = f^T = \dot{\underline{x}}^T \end{cases} \Rightarrow \frac{d\mathcal{H}}{dt} = -\dot{\underline{\lambda}}^T(t) \frac{d\underline{x}}{dt} + \frac{\partial \mathcal{H}^T}{\partial \underline{u}} \frac{d\underline{u}}{dt} + \dot{\underline{x}}^T \frac{d\underline{\lambda}}{dt} \quad (1.150)$$

Having in mind that the Hamiltonian \mathcal{H} is a scalar functional we get:

$$\dot{\underline{\lambda}}^T(t) \frac{d\underline{x}}{dt} = \dot{\underline{x}}^T(t) \frac{d\underline{\lambda}}{dt} \Rightarrow \frac{d\mathcal{H}}{dt} = \frac{\partial \mathcal{H}^T}{\partial \underline{u}} \frac{d\underline{u}}{dt} \quad (1.151)$$

Finally, assuming no constraint on input $\underline{u}(t)$, we use (1.72) to obtain relation (1.147):

$$\frac{\partial \mathcal{H}}{\partial \underline{u}} = 0 \Rightarrow \frac{d\mathcal{H}}{dt} = 0 \Rightarrow \mathcal{H}(\underline{x}^*, \underline{u}^*, \underline{\lambda}^*) = \text{constant} \quad (1.152)$$

Example 1.2. As in example 1.1 we consider again the problem of finding the shortest distance between two points $P_1 = (x_1, y_1)$ and $P_2 = (x_2, y_2)$ in the euclidean plane.

Setting $u(x) = y'(x)$ the length of the path between the two points is defined by:

$$J(u(x)) = \int_{P_1}^{P_2} \sqrt{dx^2 + dy^2} = \int_{x_1}^{x_2} \sqrt{1 + u(x)^2} dx \quad (1.153)$$

¹¹[https://en.wikipedia.org/wiki/Hamiltonian_\(control_theory\)](https://en.wikipedia.org/wiki/Hamiltonian_(control_theory))

Here $J(u(x))$ is the performance index to be minimized under the following constraints:

$$\begin{cases} y'(x) = u(x) \\ y(x_1) = y_1 \\ y(x_2) = y_2 \end{cases} \quad (1.154)$$

Let $\lambda(x)$ be the Lagrange multiplier, which is here a scalar. The Hamiltonian \mathcal{H} reads:

$$\mathcal{H} = \sqrt{1 + u^2(x)} + \lambda(x)u(x) \quad (1.155)$$

The necessary conditions for optimality are the following:

$$\begin{cases} \frac{\partial \mathcal{H}}{\partial y} = -\lambda'(x) \Leftrightarrow \lambda'(x) = 0 \\ \frac{\partial \mathcal{H}}{\partial u} = 0 \Leftrightarrow \frac{u(x)}{\sqrt{1+u^2(x)}} + \lambda(x) = 0 \end{cases} \quad (1.156)$$

Denoting by c a constant we get from the first equation of (1.156):

$$\lambda(x) = c \quad (1.157)$$

Using this relation in the second equation of (1.156) leads to the following expression of $u(x)$ where constant a is introduced:

$$\frac{u(x)}{\sqrt{1+u^2(x)}} + c = 0 \Rightarrow u^2(x) = \frac{c^2}{1-c^2} \Rightarrow u(x) = \sqrt{\frac{c^2}{1-c^2}} := a = \text{constant} \quad (1.158)$$

Thus, the shortest distance between two fixed points in the euclidean plane is a curve with constant slope, that is a straight-line:

$$y(x) = ax + b \quad (1.159)$$

We obviously retrieve the result of example 1.1.

Moreover, we can check that over the optimal trajectory the Hamiltonian \mathcal{H} is constant (not null because here the final value of x is set to x_2). Indeed:

$$\begin{cases} \lambda(x) = c \\ u(x) = \sqrt{\frac{c^2}{1-c^2}} \end{cases} \Rightarrow \mathcal{H} = \sqrt{1 + u^2(x)} + \lambda(x)u(x) = \text{constant} \quad (1.160)$$

■

1.11.3 Free final time

It is worth noticing that if final time t_f is not specified, and after having noticed that $f(t_f) - \dot{x}(t_f) = 0$, the following term shall be added to δJ_a in (1.62):

$$\left(F(t_f) + \frac{\partial G(\underline{x}(t_f))^T}{\partial \underline{x}} f(t_f) \right) \delta t_f \quad (1.161)$$

In this case the first variation of the augmented performance index with respect to δt_f is zero as soon as:

$$F(t_f) + \frac{\partial G(\underline{x}(t_f))^T}{\partial \underline{x}} f(t_f) = 0 \quad (1.162)$$

As far as boundary conditions (1.70) apply we get:

$$\underline{\lambda}(t_f) = \frac{\partial G(\underline{x}(t_f))}{\partial \underline{x}(t_f)} \Rightarrow F(t_f) + \underline{\lambda}(t_f)f(t_f) = 0 \quad (1.163)$$

The preceding equation is called transversality condition. We recognize in $F(t_f) + \underline{\lambda}(t_f)f(t_f)$ the value of the *Hamiltonian function* $\mathcal{H}(t)$ defined in (1.63) at final time t_f . Because the Hamiltonian $\mathcal{H}(t)$ is constant along an optimal trajectory for an autonomous system (see (1.147)) it is concluded that $\mathcal{H}(t) = 0$ along an optimal trajectory for an autonomous system when final time t_f is free.

Alternatively we can introduce a new variable, denoted s for example, which is related to time t as follows:

$$t(s) = t_0 + (t_f - t_0)s \quad \forall s \in [0, 1] \quad (1.164)$$

From the preceding equation we get:

$$dt = (t_f - t_0) ds \quad (1.165)$$

Then the optimal control problem with respect to time t where the final time t_f is free is changed into an optimal control problem with respect to new variable s and an additional state $t_f(s)$ which is constant with respect to s . The optimal control problem reads:

Minimize:

$$J(\underline{u}(s)) = G(\underline{x}(1)) + \int_0^1 (t_f(s) - t_0) F(\underline{x}(s), \underline{u}(s)) ds \quad (1.166)$$

Under the following constraints:

– Dynamics and boundary conditions:

$$\begin{cases} \frac{d}{ds}\underline{x}(s) = \frac{d\underline{x}(t)}{dt} \frac{dt}{ds} = (t_f(s) - t_0)f(\underline{x}(s), \underline{u}(s)) \\ \frac{d}{ds}t_f(s) = 0 \\ \underline{x}(0) = \underline{x}_0 \end{cases} \quad (1.167)$$

– Mixed control-state constraints:

$$c(\underline{x}(s), \underline{u}(s)) \leq 0, \text{ where } c(\underline{x}(s), \underline{u}(s)) : \mathbb{R}^n \times \mathbb{R}^m \rightarrow \mathbb{R} \quad (1.168)$$

1.12 Bang-bang control

1.12.1 Pontryagin's principle application

Bang-bang control is a term used to indicate that the control \underline{u} switches abruptly between two values. It appears when the control \underline{u} is restricted to be between a lower and an upper bound. We apply Pontryagin's principle in the following cases:

- For a problem where the *Hamiltonian function* \mathcal{H} is linear in the *scalar control* u we can write:

$$\mathcal{H} = a + \sigma u \quad (1.169)$$

When *scalar control* u is limited between u_{min} and u_{max} , Pontryagin's principle provides the following necessary condition for optimality:

$$u_{min} \leq u(t) \leq u_{max} \Rightarrow u(t) = \begin{cases} u_{max} & \text{if } \sigma(t) = \frac{\partial \mathcal{H}}{\partial u} < 0 \\ u_{min} & \text{if } \sigma(t) = \frac{\partial \mathcal{H}}{\partial u} > 0 \\ \in [u_{min}, u_{max}] & \text{if } \sigma(t) = \frac{\partial \mathcal{H}}{\partial u} = 0 \end{cases} \quad (1.170)$$

- For multi-inputs systems, suppose that the *Hamiltonian function* \mathcal{H} is related to the control *vector* $\underline{u}(t)$ as follows:

$$\mathcal{H} = a + \underline{b}^T \underline{u} + \|\underline{u}\| \quad \text{where } \underline{b} \neq \underline{0} \quad (1.171)$$

Cauchy–Schwartz inequality may be applied to get¹²:

$$\underline{b}^T \underline{u} \geq -\|\underline{b}\| \|\underline{u}\| \Rightarrow \mathcal{H} \geq a + \|\underline{u}\| (1 - \|\underline{b}\|) \quad (1.172)$$

and the equality is obtained when \underline{u} is proportionnal to \underline{b} :

$$\underline{u} = -\alpha \frac{\underline{b}}{\|\underline{b}\|} \quad \text{where } \alpha \geq 0 \quad (1.173)$$

Moreover Pontryagin's principle provides the following necessary condition for optimality¹², assuming that $\|\underline{u}\| \leq u_{max}$:

$$\|\underline{u}\| \leq u_{max} \Rightarrow \alpha = \begin{cases} u_{max} & \text{if } \sigma < 0 \\ 0 & \text{if } \sigma > 0 \\ \in [0, u_{max}] & \text{if } \sigma = 0 \end{cases} \quad \text{where } \sigma = 1 - \|\underline{b}\| \quad (1.174)$$

Function σ is usually called the switching function. Thus optimal control $u(t)$ switches at times when switching function σ switches from negative to positive (or vice-versa). This type of control where the control is always set to boundary values is called *bang-bang control*.

In addition, and as the unconstrained control case, the *Hamiltonian functional* \mathcal{H} remains constant along an optimal trajectory for an autonomous system when there are constraints on input $\underline{u}(t)$. Indeed in that situation control $\underline{u}(t)$ is constant (it is set either to its minimum or maximum value) and consequently $\frac{d\underline{u}}{dt}$ is zero. From (1.151) we get $\frac{d\mathcal{H}}{dt} = 0$.

¹²Bertrand R., Epenoy R., New smoothing techniques for solving bang-bang optimal control problems - Numerical results and statistical interpretation, Optimal Control Applications and Methods 23(4):171 - 197, July 2002, DOI:10.1002/oca.709

Last but not least, assume that the performance index to be minimized reads as follows where $\lambda_0 > 0$:

$$J(\underline{u}(t)) = \frac{\lambda_0}{2} \int_0^{t_f} \|\underline{u}(t)\| dt \quad (1.175)$$

Then, as suggested by Bertrand & Epenoy¹², it could be valuable to deduce the solution of the initial problem from the successive solutions of an auxiliary problem through an homotopic approach by defining the following perturbed performance index:

$$J_\epsilon(\underline{u}(t)) = \frac{\lambda_0}{2} \int_0^{t_f} (\|\underline{u}(t)\| - \epsilon h(\|\underline{u}(t)\|)) dt \quad (1.176)$$

Parameter ϵ is assumed to be in the interval $]0, 1]$ and function h is a continuous function satisfying $h(w) \geq 0 \forall w \in [0, 1]$. For example, one could choose $h(w) = w - w^2$; with this choice $\|\underline{u}(t)\| - \epsilon h(\|\underline{u}(t)\|) = \|\underline{u}(t)\|^2$ for $\epsilon = 1$ and $\|\underline{u}(t)\| - \epsilon h(\|\underline{u}(t)\|) = \|\underline{u}(t)\|$ for $\epsilon = 0$.

If $h(w) \rightarrow \infty$ as w approaches 1 or 0, then h is called a barrier function, otherwise it is a penalty function.

The homotopic (or continuation) approach¹² consists in solving the perturbed problem with $\epsilon = 1$. Then, after defining a decreasing sequence of ϵ values ($\epsilon_1 = 1 > \epsilon_2 > \dots > \epsilon_n > 0$), the current optimal control problem associated with $\epsilon = \epsilon_k$ where $k = 2, \dots, n$ is solved with the solution of the previous one as a starting point.

1.12.2 Example 1

Consider a simple mass m which moves on the x -axis and is subject to a force $f(t)$ ¹³. Equation of motion reads:

$$m\ddot{y}(t) = f(t) \quad (1.177)$$

We set control $u(t)$ as:

$$u(t) = \frac{f(t)}{m} \quad (1.178)$$

Consequently the equation of motion reduces to:

$$\ddot{y}(t) = u(t) \quad (1.179)$$

The state space realization of this system is the following:

$$\begin{cases} x_1(t) = y(t) \\ x_2(t) = \dot{y}(t) \end{cases} \Rightarrow \begin{cases} \dot{x}_1(t) = x_2(t) \\ \dot{x}_2(t) = u(t) \end{cases} \Leftrightarrow f(x, u) = \begin{bmatrix} x_2(t) \\ u(t) \end{bmatrix} \quad (1.180)$$

We will assume that the initial position of the mass is zero and that the movement starts from rest:

$$\begin{cases} y(0) = 0 \\ \dot{y}(0) = 0 \end{cases} \quad (1.181)$$

¹³ Linear Systems: Optimal and Robust Control 1st Edition, by Alok Sinha, CRC Press

We will assume that control $u(t)$ is subject to the following constraint:

$$u_{min} \leq u(t) \leq u_{max} \quad (1.182)$$

First we are looking for the optimal control $u(t)$ which enables the mass to cover the maximum distance in a fixed time t_f :

The objective of the problem is to maximize $y(t_f)$. This corresponds to minimize the opposite of $y(t_f)$; consequently the cost $J(u(t))$ reads as follows where $F(x, u) = 0$ when compared to (1.56):

$$J(u(t)) = G(x(t_f)) = -y(t_f) := -x_1(t_f) \quad (1.183)$$

As $F(x, u) = 0$ the Hamiltonian for this problem reads:

$$\begin{aligned} \mathcal{H}(\underline{x}, u, \underline{\lambda}) &= \lambda(t)^T f(x, u) \\ &= [\lambda_1(t) \quad \lambda_2(t)] \begin{bmatrix} x_2(t) \\ u(t) \end{bmatrix} \\ &= \lambda_1(t)x_2(t) + \lambda_2(t)u(t) \end{aligned} \quad (1.184)$$

Adjoint equations read:

$$\dot{\lambda}(t) = -\frac{\partial \mathcal{H}}{\partial x} \Leftrightarrow \begin{cases} \dot{\lambda}_1(t) = -\frac{\partial \mathcal{H}}{\partial x_1} = 0 \\ \dot{\lambda}_2(t) = -\frac{\partial \mathcal{H}}{\partial x_2} = -\lambda_1(t) \end{cases} \quad (1.185)$$

Solutions of adjoint equations are the following where c and d are constants:

$$\begin{cases} \lambda_1(t) = c \\ \lambda_2(t) = -ct + d \end{cases} \quad (1.186)$$

As far as final time t_f is not specified values of constants c and d are determined by transversality condition (1.70):

$$\lambda(t_f) = \frac{\partial G(x(t_f))}{\partial x(t_f)} \Rightarrow \begin{cases} \lambda_1(t_f) = \frac{\partial(-x_1(t_f))}{\partial x_1(t_f)} = -1 \\ \lambda_2(t_f) = \frac{\partial(-x_1(t_f))}{\partial x_2(t_f)} = 0 \end{cases} \quad (1.187)$$

Consequently:

$$\begin{cases} c = -1 \\ d = -t_f \end{cases} \Rightarrow \begin{cases} \lambda_1(t) = -1 \\ \lambda_2(t) = t - t_f \end{cases} \quad (1.188)$$

Thus the Hamiltonian \mathcal{H} reads as follows:

$$\mathcal{H}(\underline{x}, u, \underline{\lambda}) = \lambda_1(t)x_2(t) + \lambda_2(t)u(t) = -x_2(t) + (t - t_f)u(t) \quad (1.189)$$

Then $\frac{\partial \mathcal{H}}{\partial u} = t - t_f \leq 0 \forall 0 \leq t \leq t_f$. Applying (1.170) leads to the expression of control $u(t)$:

$$\frac{\partial \mathcal{H}}{\partial u} \leq 0 \Rightarrow u(t) = u_{max} \quad \forall 0 \leq t \leq t_f \quad (1.190)$$

This is of common sense when the objective is to cover the maximum distance in a fixed time without any constraint on the vehicle velocity at the

final time. The optimal state trajectory can be easily obtained by solving the state equations with given initial conditions:

$$\begin{cases} \dot{x}_1 = x_2 \\ \dot{x}_2 = u_{max} \end{cases} \Rightarrow \begin{cases} x_1(t) = \frac{1}{2}u_{max}t^2 \\ x_2(t) = u_{max}t \end{cases} \quad (1.191)$$

The Hamiltonian along the optimal trajectory has the following value:

$$\mathcal{H}(\underline{x}, u, \underline{\lambda}) = \lambda_1(t)x_2(t) + \lambda_2(t)u(t) = -u_{max}t + (t - t_f)u_{max} = -u_{max}t_f \quad (1.192)$$

As expected the Hamiltonian along the optimal trajectory is constant. The minimum value of the performance index is:

$$J(u(t)) = -x_1(t_f) = -\frac{1}{2}u_{max}t_f^2 \quad (1.193)$$

Alternatively, we can write $J(u(t))$ as follows:

$$J(u(t)) = -y(t_f) = \int_0^{t_f} \left(-\frac{dy}{dt}\right) dt = \int_0^{t_f} (-x_2(t)) dt \quad (1.194)$$

The Hamiltonian for this equivalent $J(u(t))$ now reads:

$$\begin{aligned} \mathcal{H}(\underline{x}, u, \underline{\lambda}) &= -x_2(t) + \lambda(t)^T f(x, u) \\ &= -x_2(t) + \lambda_1(t)x_2(t) + \lambda_2(t)u(t) \end{aligned} \quad (1.195)$$

Adjoint equations become:

$$\dot{\lambda}(t) = -\frac{\partial \mathcal{H}}{\partial x} \Leftrightarrow \begin{cases} \dot{\lambda}_1(t) = -\frac{\partial \mathcal{H}}{\partial x_1} = 0 \\ \dot{\lambda}_2(t) = -\frac{\partial \mathcal{H}}{\partial x_2} = 1 - \lambda_1(t) \end{cases} \quad (1.196)$$

Solutions of adjoint equations are the following where c and d are constants:

$$\begin{cases} \lambda_1(t) = c \\ \lambda_2(t) = (1 - c)t + d \end{cases} \quad (1.197)$$

Because the final value of $\underline{x}(t_f)$ is no specified, we have $G(x(t_f)) = 0$ and the transversality condition (1.70) now reads:

$$G(x(t_f)) = 0 \Rightarrow \lambda(t_f) = \frac{\partial G(x(t_f))}{\partial x(t_f)} = 0 \Rightarrow \begin{cases} \lambda_1(t_f) = \frac{\partial(-x_1(t_f))}{\partial x_1(t_f)} = 0 \\ \lambda_2(t_f) = \frac{\partial(-x_1(t_f))}{\partial x_2(t_f)} = 0 \end{cases} \quad (1.198)$$

Consequently:

$$\begin{cases} c = 0 \\ d = -t_f \end{cases} \Rightarrow \begin{cases} \lambda_1(t) = 0 \\ \lambda_2(t) = t - t_f \end{cases} \quad (1.199)$$

Obviously, we retrieve the same expressions for $\lambda_1(t)$ and $\lambda_2(t)$ than those obtained previously, and we finally get the same bang-bang optimal control.

1.12.3 Example 2

We re-use the preceding example but now we are looking for the optimal control $u(t)$ which enables the mass to cover the maximum distance in a fixed time t_f with the additional constraint that the final velocity is equal to zero:

$$x_2(t_f) = 0 \quad (1.200)$$

The solution of this problem starts as in the previous case and leads to the solution of adjoint equations where c and d are constants:

$$\begin{cases} \lambda_1(t) = c \\ \lambda_2(t) = -ct + d \end{cases} \quad (1.201)$$

The difference when compared with the previous case is that now the final velocity is equal to zero, that is $x_2(t_f) = 0$. Consequently transversality condition (1.70) involves only state x_1 and reads as follows:

$$\lambda(t_f) = \frac{\partial G(x(t_f))}{\partial x(t_f)} \Leftrightarrow \lambda_1(t_f) = \frac{\partial(-x_1(t_f))}{\partial x_1(t_f)} = -1 \quad (1.202)$$

Taking into account (1.202) into (1.201) leads to:

$$\begin{cases} \lambda_1(t) = -1 \\ \lambda_2(t) = t + d \end{cases} \quad (1.203)$$

The Hamiltonian \mathcal{H} reads as follows:

$$\mathcal{H}(x, u, \lambda) = \lambda_1(t)x_2(t) + \lambda_2(t)u(t) = -x_2(t) + (t + d)u(t) \quad (1.204)$$

Thus $\frac{\partial \mathcal{H}}{\partial u} = t + d = \lambda_2(t) \forall 0 \leq t \leq t_f$ where the value of constant d is not known: it can be either $d < -t_f$, $d \in [-t_f, 0]$ or $d > 0$. Figure 1.1 plots the three possibilities.

- The possibility $d < -t_f$ leads to $u(t) = u_{min} \forall t \in [0, t_f]$ according to (1.170), that is $y(t) := x_1(t) = 0.5u_{min}t^2$ when taking into account initial conditions (1.181). Thus there is no way to achieve the constraint that the velocity is zero at instant t_f and the possibility $d < -t_f$ is ruled out;
- Similarly, the possibility $d > 0$ leads to $u(t) = u_{max} \forall t \in [0, t_f]$, that is $y(t) := x_1(t) = 0.5u_{max}t^2$ when taking into account initial conditions (1.181). Thus the possibility $d > 0$ is also ruled out.

Hence d shall be chosen between $-t_f$ and 0. According to (1.170) and Figure 1.1 we have:

$$u(t) = \begin{cases} u_{max} \quad \forall 0 \leq t \leq t_s \\ u_{min} \quad \forall t_s < t \leq t_f \end{cases} \quad (1.205)$$

Instant t_s is the switching instant, that is time at which $\frac{\partial \mathcal{H}}{\partial u} = \lambda_2(t)$ changes in sign. Solving the state equations with initial velocity set to zero yields the

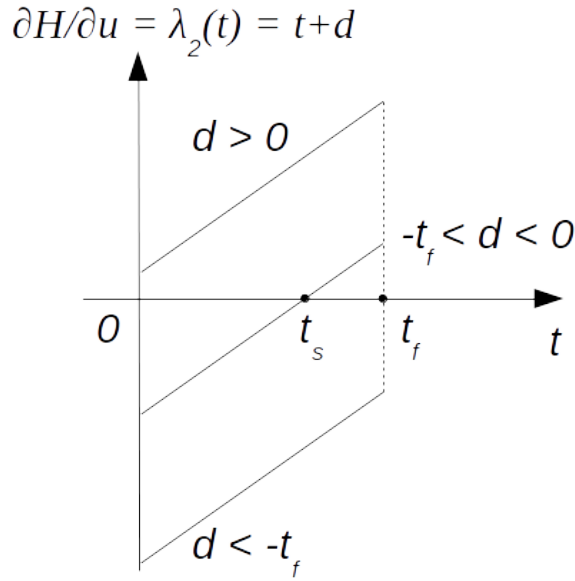
Figure 1.1: Three possibilities for the values of $\partial\mathcal{H}/\partial u = \lambda_2(t)$

expression of $x_2(t) \forall t_s < t \leq t_f$:

$$\begin{cases} \dot{x}_2 = u_{max} \quad \forall 0 \leq t \leq t_s \\ \dot{x}_2 = u_{min} \quad \forall t_s < t \leq t_f \\ x_2(0) = 0 \end{cases} \quad (1.206)$$

$$\Rightarrow \begin{cases} x_2(t_s) = u_{max}t_s \\ x_2(t) = u_{max}t_s + u_{min}(t - t_s) \quad \forall t_s < t \leq t_f \end{cases}$$

Imposing $x_2(t_f) = 0$ leads to the value of the switching instant t_s :

$$\begin{aligned} x_2(t_f) = 0 &\Rightarrow u_{max}t_s + u_{min}(t_f - t_s) = 0 \\ &\Rightarrow t_s = \frac{u_{min}t_f}{u_{min} - u_{max}} = -\frac{u_{min}t_f}{u_{max} - u_{min}} \end{aligned} \quad (1.207)$$

From Figure 1.1 it is clear that at $t = t_s$ we have $\lambda_2(t_s) = 0$. Using the fact that $\lambda_2(t) = t + d$ we finally get the value of constant d :

$$\begin{cases} \lambda_2(t) = t + d \\ \lambda_2(t_s) = 0 \end{cases} \Rightarrow d = -t_s \quad (1.208)$$

Furthermore the Hamiltonian along the optimal trajectory has the following value:

$$\begin{cases} \forall 0 \leq t \leq t_s \quad \mathcal{H}(\underline{x}, u, \underline{\lambda}) &= \lambda_1(t)x_2(t) + \lambda_2(t)u(t) \\ &= -u_{max}t + (t + d)u_{max} = -t_s u_{max} \\ \forall t_s < t \leq t_f \quad \mathcal{H}(\underline{x}, u, \underline{\lambda}) &= -u_{max}t_s - u_{min}(t - t_s) + (t - t_s)u_{max} \\ &= -t_s u_{max} \end{cases} \quad (1.209)$$

As expected the Hamiltonian along the optimal trajectory is constant.

1.13 Singular arc - Legendre-Clebsch condition

The case where $\partial\mathcal{H}/\partial\mathbf{u}$ does not yield to a definite value for the control $\mathbf{u}(t)$ is called *singular* control. Usually singular control arises when a multiplier $\sigma(t)$ of the control $\mathbf{u}(t)$ (which is called the switching function) in the Hamiltonian \mathcal{H} vanishes over a finite length of time $t_1 \leq t \leq t_2$:

$$\sigma(t) := \frac{\partial\mathcal{H}}{\partial\mathbf{u}} = 0 \quad \forall t_1 \leq t \leq t_2 \quad (1.210)$$

The *singular* control can be determined by the condition that the switching function $\sigma(t)$ and its time derivatives vanish along the so-called singular arc. Hence over a singular arc we have:

$$\frac{d^k}{dt^k}\sigma(t) = 0 \quad \forall t_1 \leq t \leq t_2, \quad \forall k \in \mathbb{N} \quad (1.211)$$

At some derivative order the control $\mathbf{u}(t)$ does appear explicitly and its value is thereby determined. Furthermore it can be shown that the control $\mathbf{u}(t)$ appears at an even derivative order. So the derivative order at which the control $\mathbf{u}(t)$ does appear explicitly will be denoted $2q$. Thus:

$$k := 2q \Rightarrow \frac{d^{2q}\sigma(t)}{dt^{2q}} := A(t, \mathbf{x}, \lambda) + B(t, \mathbf{x}, \lambda)\mathbf{u} = 0 \quad (1.212)$$

The previous equation gives an explicit equation for the singular control, once the Lagrange multiplier λ have been obtained through the relation $\dot{\lambda}(t) = -\frac{\partial\mathcal{H}}{\partial\mathbf{x}}$.

The singular arc will be optimal if it satisfies the following generalized Legendre-Clebsch condition, which is also known as the Kelley condition¹⁴, where $2q$ is the (always even) value of k at which the control $\mathbf{u}(t)$ explicitly appears in $\frac{d^k}{dt^k}\sigma(t)$ for the first time:

$$(-1)^q \frac{\partial}{\partial\mathbf{u}} \left[\frac{d^{2q}\sigma(t)}{dt^{2q}} \right] \geq 0 \quad (1.213)$$

Note that for the *regular* arc the second order necessary condition for optimality to achieve a minimum cost is the positive semi-definiteness of the Hessian matrix of the Hamiltonian along an optimal trajectory. This condition is obtained by setting $q = 0$ in the generalized Legendre-Clebsch condition (1.213):

$$q = 0 \Rightarrow \frac{\partial}{\partial\mathbf{u}}\sigma(t) = \frac{\partial^2\mathcal{H}}{\partial\mathbf{u}^2} = \mathcal{H}_{uu} \geq 0 \quad (1.214)$$

This inequality is also termed *regular* Legendre-Clebsch condition.

¹⁴Douglas M. Pargett & Douglas Mark D. Ardema, Flight Path Optimization at Constant Altitude, Journal of Guidance Control and Dynamics, July 2007, 30(4):1197-1201, DOI: 10.2514/1.28954

Chapter 2

Finite Horizon Linear Quadratic Regulator

2.1 Problem to be solved

The Linear Quadratic Regulator (*LQR*) is an optimal control problem where the state equation of the plant is linear, the performance index is quadratic and the initial conditions are known. We discuss in this chapter linear quadratic regulation in the case where the final time which appears in the cost to be minimized is finite whereas the next chapter will focus on the infinite horizon case. The optimal control problem to be solved is the following: assume a plant driven by a linear dynamical equation of the form:

$$\begin{cases} \dot{\underline{x}}(t) = \mathbf{A}\underline{x}(t) + \mathbf{B}\underline{u}(t) \\ \underline{x}(0) = \underline{x}_0 \end{cases} \quad (2.1)$$

Where:

- \mathbf{A} is the state (or system) matrix
- \mathbf{B} is the input matrix
- $\underline{x}(t)$ is the state vector of dimension n
- $\underline{u}(t)$ is the control vector of dimension m

Then we have to find the control $\underline{u}(t)$ which minimizes the following quadratic performance index:

$$J(\underline{u}(t)) = \frac{1}{2} (\underline{x}(t_f) - \underline{x}_f)^T \mathbf{S} (\underline{x}(t_f) - \underline{x}_f) + \frac{1}{2} \int_0^{t_f} \underline{x}^T(t) \mathbf{Q} \underline{x}(t) + \underline{u}^T(t) \mathbf{R} \underline{u}(t) dt \quad (2.2)$$

where the final time t_f is set and \underline{x}_f is the final state to be reached. The performance index relates to the fact that a trade-off has been done between the rate of variation of $\underline{x}(t)$ and the magnitude of the control input $\underline{u}(t)$. Matrices

\mathbf{S} and \mathbf{Q} shall be chosen to be symmetric positive semi-definite and matrix \mathbf{R} symmetric positive definite.

$$\begin{cases} \mathbf{S} = \mathbf{S}^T \geq 0 \\ \mathbf{Q} = \mathbf{Q}^T \geq 0 \\ \mathbf{R} = \mathbf{R}^T > 0 \end{cases} \quad (2.3)$$

Notice that the use of matrix \mathbf{S} is optional; indeed, if the final state \underline{x}_f is imposed then there is no need to insert the expression $\frac{1}{2}(\underline{x}(t_f) - \underline{x}_f)^T \mathbf{S}(\underline{x}(t_f) - \underline{x}_f)$ in the cost to be minimized.

2.2 Positive definite and positive semi-definite matrix

A positive definite matrix \mathbf{M} is denoted $\mathbf{M} > 0$. We remind that a real $n \times n$ symmetric matrix $\mathbf{M} = \mathbf{M}^T$ is called positive definite if and only if we have either:

- $\underline{x}^T \mathbf{M} \underline{x} > 0$ for all $\underline{x} \neq 0$;
- All eigenvalues of \mathbf{M} are strictly positive;
- All of the leading principal minors are strictly positive (the leading principal minor of order k is the minor of order k obtained by deleting the last $n - k$ rows and columns);
- Matrix \mathbf{M} can be written as follows where matrix $\mathbf{M}^{0.5}$ is square, symmetric and invertible:

$$\mathbf{M} = \mathbf{M}^{0.5} \mathbf{M}^{0.5} \text{ where } (\mathbf{M}^{0.5})^T = \mathbf{M}^{0.5} \quad (2.4)$$

Matrix $\mathbf{M}^{0.5}$ is called the root square of matrix \mathbf{M} . By getting the modal decomposition of matrix \mathbf{M} , that is $\mathbf{M} = \mathbf{V} \mathbf{D} \mathbf{V}^{-1}$ where \mathbf{V} is the matrix whose columns are the eigenvectors of \mathbf{M} and \mathbf{D} is the diagonal matrix whose diagonal elements are the corresponding positive eigenvalues, the square root $\mathbf{M}^{0.5}$ of \mathbf{M} is given by $\mathbf{M}^{0.5} = \mathbf{V} \mathbf{D}^{0.5} \mathbf{V}^{-1}$, where $\mathbf{D}^{0.5}$ is any diagonal matrix whose elements are the square root of the diagonal elements of \mathbf{D}^1 .

Similarly a semi-definite positive matrix \mathbf{M} is denoted $\mathbf{M} \geq 0$. We remind that a $n \times n$ real symmetric matrix $\mathbf{M} = \mathbf{M}^T$ is called positive semi-definite if and only if we have either:

- $\underline{x}^T \mathbf{M} \underline{x} \geq 0$ for all $\underline{x} \neq 0$;
- All eigenvalues of \mathbf{M} are non-negative;
- All of the principal (not only leading) minors are non-negative (the principal minor of order k is the minor of order k obtained by deleting $n - k$ rows and the $n - k$ columns with the same position than the rows. For instance, in a principal minor where you have deleted rows 1 and 3, you should also delete columns 1 and 3);

¹https://en.wikipedia.org/wiki/Square_root_of_a_matrix

- Matrix \mathbf{M} can be written as $(\mathbf{M}^{0.5})^T \mathbf{M}^{0.5}$ where matrix $\mathbf{M}^{0.5}$ is full row rank.

Furthermore a real symmetric matrix \mathbf{M} is called negative (semi-)definite if $-\mathbf{M}$ is positive (semi-)definite.

Example 2.1. Check that $\mathbf{M}_1 = \mathbf{M}_1^T = \begin{bmatrix} 1 & 2 \\ 2 & 3 \end{bmatrix}$ is not positive definite and that $\mathbf{M}_2 = \mathbf{M}_2^T = \begin{bmatrix} 1 & -2 \\ -2 & 5 \end{bmatrix}$ is positive definite. ■

2.3 Hamiltonian matrix

For this optimal control problem, the Hamiltonian (1.63) reads:

$$\mathcal{H}(\underline{x}, \underline{u}, \underline{\lambda}) = \frac{1}{2} (\underline{x}^T(t) \mathbf{Q} \underline{x}(t) + \underline{u}^T(t) \mathbf{R} \underline{u}(t)) + \underline{\lambda}^T(t) (\mathbf{A} \underline{x}(t) + \mathbf{B} \underline{u}(t)) \quad (2.5)$$

The necessary condition for optimality (1.72) yields:

$$\frac{\partial \mathcal{H}}{\partial \underline{u}} = \mathbf{R} \underline{u}(t) + \mathbf{B}^T \underline{\lambda}(t) = \underline{0} \quad (2.6)$$

Taking into account that \mathbf{R} is a symmetric matrix, we get:

$$\underline{u}(t) = -\mathbf{R}^{-1} \mathbf{B}^T \underline{\lambda}(t) \quad (2.7)$$

Eliminating $\underline{u}(t)$ in equation (2.1) reads:

$$\begin{cases} \dot{\underline{x}}(t) = \mathbf{A} \underline{x}(t) - \mathbf{B} \mathbf{R}^{-1} \mathbf{B}^T \underline{\lambda}(t) \\ \underline{x}(0) = \underline{x}_0 \end{cases} \quad (2.8)$$

The dynamics of Lagrange multipliers $\underline{\lambda}(t)$ is given by (see (1.69)):

$$\dot{\underline{\lambda}}(t) = -\frac{\partial \mathcal{H}}{\partial \underline{x}} = -\mathbf{Q} \underline{x}(t) - \mathbf{A}^T \underline{\lambda}(t) \quad (2.9)$$

The final values of the Lagrange multipliers are given by (1.70). Using the fact that \mathbf{S} is a symmetric matrix we get:

$$\underline{\lambda}(t_f) = \frac{\partial}{\partial \underline{x}(t_f)} \left(\frac{1}{2} (\underline{x}(t_f) - \underline{x}_f)^T \mathbf{S} (\underline{x}(t_f) - \underline{x}_f) \right) = \mathbf{S} (\underline{x}(t_f) - \underline{x}_f) \quad (2.10)$$

Taking into account that matrices \mathbf{Q} and \mathbf{S} are symmetric matrices, equations (2.9) and (2.10) are written as follows:

$$\begin{cases} \dot{\underline{\lambda}}(t) = -\mathbf{Q} \underline{x}(t) - \mathbf{A}^T \underline{\lambda}(t) \\ \underline{\lambda}(t_f) = \mathbf{S} (\underline{x}(t_f) - \underline{x}_f) \end{cases} \quad (2.11)$$

Equations (2.8) and (2.11) represent a two-point boundary value problem. Combining (2.8) and (2.11) into a single state equation yields:

$$\begin{bmatrix} \dot{\underline{x}}(t) \\ \dot{\underline{\lambda}}(t) \end{bmatrix} = \begin{bmatrix} \mathbf{A} & -\mathbf{B} \mathbf{R}^{-1} \mathbf{B}^T \\ -\mathbf{Q} & -\mathbf{A}^T \end{bmatrix} \begin{bmatrix} \underline{x}(t) \\ \underline{\lambda}(t) \end{bmatrix} = \mathbf{H} \begin{bmatrix} \underline{x}(t) \\ \underline{\lambda}(t) \end{bmatrix} \quad (2.12)$$

where we have introduced the Hamiltonian matrix \mathbf{H} defined by:

$$\mathbf{H} = \begin{bmatrix} \mathbf{A} & -\mathbf{B}\mathbf{R}^{-1}\mathbf{B}^T \\ -\mathbf{Q} & -\mathbf{A}^T \end{bmatrix} \quad (2.13)$$

By definition, a matrix \mathbf{H} is said to be an Hamiltonian matrix as soon as the following property holds:

$$(\mathbf{J}\mathbf{H})^T = \mathbf{J}\mathbf{H} \quad (2.14)$$

where \mathbf{J} is the following skew-symmetric matrix:

$$\mathbf{J} = -\mathbf{J}^T = \begin{bmatrix} \mathbf{0} & \mathbb{I} \\ -\mathbb{I} & \mathbf{0} \end{bmatrix} \quad (2.15)$$

2.4 Optimal control

2.4.1 State vector expression

Solving (2.12) yields:

$$\begin{bmatrix} \underline{x}(t) \\ \underline{\lambda}(t) \end{bmatrix} = e^{\mathbf{H}t} \begin{bmatrix} \underline{x}(0) \\ \underline{\lambda}(0) \end{bmatrix} \quad (2.16)$$

In the previous equation, the value of $\underline{\lambda}(0)$ is not known. On the other hand, $\underline{x}(t_f)$ or $\underline{\lambda}(t_f)$ is known, depending on whether the final state is imposed or weighted. Thus by replacing t by $t - t_f$ in the previous equation we obtain:

$$\begin{bmatrix} \underline{x}(t) \\ \underline{\lambda}(t) \end{bmatrix} = e^{\mathbf{H}t} \begin{bmatrix} \underline{x}(0) \\ \underline{\lambda}(0) \end{bmatrix} = e^{\mathbf{H}(t-t_f)} \begin{bmatrix} \underline{x}(t_f) \\ \underline{\lambda}(t_f) \end{bmatrix} \quad (2.17)$$

Then exponential matrix $e^{\mathbf{H}(t-t_f)}$ is partitioned as follows:

$$e^{\mathbf{H}(t-t_f)} := \begin{bmatrix} \mathbf{Y}_1(t) & \mathbf{X}_1(t) \\ \mathbf{Y}_2(t) & \mathbf{X}_2(t) \end{bmatrix} \quad (2.18)$$

Then (2.17) yields:

$$\begin{cases} \underline{x}(t) = \mathbf{Y}_1(t) \underline{x}(t_f) + \mathbf{X}_1(t) \underline{\lambda}(t_f) \\ \underline{\lambda}(t) = \mathbf{Y}_2(t) \underline{x}(t_f) + \mathbf{X}_2(t) \underline{\lambda}(t_f) \end{cases} \quad (2.19)$$

Furthermore notice the following relations obtained when $t = t_f$:

$$e^{\mathbf{H}(t-t_f)} \Big|_{t=t_f} = \mathbb{I} := \begin{bmatrix} \mathbf{Y}_1(t_f) & \mathbf{X}_1(t_f) \\ \mathbf{Y}_2(t_f) & \mathbf{X}_2(t_f) \end{bmatrix} \Rightarrow \begin{cases} \mathbf{Y}_1(t_f) = \mathbf{X}_2(t_f) = \mathbb{I} \\ \mathbf{X}_1(t_f) = \mathbf{Y}_2(t_f) = \mathbf{0} \end{cases} \quad (2.20)$$

2.4.2 Lagrange multipliers for imposed final state

Assume that the final state $\underline{x}(t_f)$ is imposed:

$$\underline{x}(t_f) := \underline{x}_f \quad (2.21)$$

Then (2.19) can be manipulated to get rid of the unknown vector $\underline{\lambda}(t_f)$:

$$\begin{cases} \underline{\lambda}(t_f) = \mathbf{X}_1^{-1}(t) (\underline{x}(t) - \mathbf{Y}_1(t) \underline{x}_f) \\ \underline{\lambda}(t_f) = \mathbf{X}_2^{-1}(t) (\underline{\lambda}(t) - \mathbf{Y}_2(t) \underline{x}_f) \end{cases} \quad (2.22)$$

Then equating $\underline{\lambda}(t_f) = \underline{\lambda}(t_f)$ we get:

$$\begin{aligned} \mathbf{X}_2^{-1}(t) (\underline{\lambda}(t) - \mathbf{Y}_2(t) \underline{x}_f) &= \mathbf{X}_1^{-1}(t) (\underline{x}(t) - \mathbf{Y}_1(t) \underline{x}_f) \\ \Leftrightarrow \underline{\lambda}(t) &= \mathbf{X}_2(t) \mathbf{X}_1^{-1}(t) (\underline{x}(t) - \mathbf{Y}_1(t) \underline{x}_f) + \mathbf{Y}_2(t) \underline{x}_f \\ \Leftrightarrow \underline{\lambda}(t) &= \mathbf{X}_2(t) \mathbf{X}_1^{-1}(t) \underline{x}(t) - (\mathbf{X}_2(t) \mathbf{X}_1^{-1}(t) \mathbf{Y}_1(t) - \mathbf{Y}_2(t)) \underline{x}_f \end{aligned} \quad (2.23)$$

In order to factor $\underline{x}(t)$ and \underline{x}_f , let $\mathbf{P}(t)$ and $\mathbf{F}(t)$ be the following matrices:

$$\begin{cases} \mathbf{P}(t) := \mathbf{X}_2(t) \mathbf{X}_1^{-1}(t) \\ \mathbf{F}(t) := \mathbf{P}(t) \mathbf{Y}_1(t) - \mathbf{Y}_2(t) \end{cases} \quad (2.24)$$

We finally get:

$$\boxed{\underline{\lambda}(t) = \mathbf{P}(t) \underline{x}(t) - \mathbf{F}(t) \underline{x}_f} \quad (2.25)$$

2.4.3 Lagrange multipliers for weighted final state

In the case where final state $\underline{x}(t_f)$ is expected to be close to the final value \underline{x}_f then the final condition $\underline{\lambda}(t_f)$ is given by (2.10):

$$\underline{\lambda}(t_f) = \mathbf{S} (\underline{x}(t_f) - \underline{x}_f) \quad (2.26)$$

Then (2.19) can be manipulated to get rid of the unknown vector $\underline{x}(t_f)$:

$$\begin{aligned} \underline{x}(t) &= \mathbf{Y}_1(t) \underline{x}(t_f) + \mathbf{X}_1(t) \underline{\lambda}(t_f) \\ &= \mathbf{Y}_1(t) \underline{x}(t_f) + \mathbf{X}_1(t) \mathbf{S} (\underline{x}(t_f) - \underline{x}_f) \\ &= (\mathbf{Y}_1(t) + \mathbf{X}_1(t) \mathbf{S}) \underline{x}(t_f) - \mathbf{X}_1(t) \mathbf{S} \underline{x}_f \\ \Rightarrow \underline{x}(t_f) &= (\mathbf{Y}_1(t) + \mathbf{X}_1(t) \mathbf{S})^{-1} (\underline{x}(t) + \mathbf{X}_1(t) \mathbf{S} \underline{x}_f) \\ \text{and } \underline{\lambda}(t) &= \mathbf{Y}_2(t) \underline{x}(t_f) + \mathbf{X}_2(t) \underline{\lambda}(t_f) \\ &= \mathbf{Y}_2(t) \underline{x}(t_f) + \mathbf{X}_2(t) \mathbf{S} (\underline{x}(t_f) - \underline{x}_f) \\ &= (\mathbf{Y}_2(t) + \mathbf{X}_2(t) \mathbf{S}) \underline{x}(t_f) - \mathbf{X}_2(t) \mathbf{S} \underline{x}_f \\ \Rightarrow \underline{x}(t_f) &= (\mathbf{Y}_2(t) + \mathbf{X}_2(t) \mathbf{S})^{-1} (\underline{\lambda}(t) + \mathbf{X}_2(t) \mathbf{S} \underline{x}_f) \end{aligned} \quad (2.27)$$

Then equating $\underline{x}(t_f) = \underline{x}(t_f)$:

$$\begin{aligned} (\mathbf{Y}_2(t) + \mathbf{X}_2(t) \mathbf{S})^{-1} (\underline{\lambda}(t) + \mathbf{X}_2(t) \mathbf{S} \underline{x}_f) \\ = (\mathbf{Y}_1(t) + \mathbf{X}_1(t) \mathbf{S})^{-1} (\underline{x}(t) + \mathbf{X}_1(t) \mathbf{S} \underline{x}_f) \end{aligned} \quad (2.28)$$

Thus:

$$\begin{aligned} \underline{\lambda}(t) = (\mathbf{Y}_2(t) + \mathbf{X}_2(t) \mathbf{S}) \left((\mathbf{Y}_1(t) + \mathbf{X}_1(t) \mathbf{S})^{-1} (\underline{x}(t) + \mathbf{X}_1(t) \mathbf{S} \underline{x}_f) \right) \\ - \mathbf{X}_2(t) \mathbf{S} \underline{x}_f \end{aligned} \quad (2.29)$$

In order to factor $\underline{x}(t)$ and \underline{x}_f , let $\mathbf{P}_S(t)$ and $\mathbf{F}_S(t)$ be the following matrices:

$$\begin{cases} \mathbf{P}_S(t) := (\mathbf{Y}_2(t) + \mathbf{X}_2(t) \mathbf{S}) (\mathbf{Y}_1(t) + \mathbf{X}_1(t) \mathbf{S})^{-1} \\ \mathbf{F}_S(t) := (\mathbf{X}_2(t) - \mathbf{P}_S(t) \mathbf{X}_1(t)) \mathbf{S} \end{cases} \quad (2.30)$$

We finally get:

$$\boxed{\underline{\lambda}(t) = \mathbf{P}_S(t) \underline{x}(t) - \mathbf{F}_S(t) \underline{x}_f} \quad (2.31)$$

2.4.4 Limit values when final state weighting matrix increases

In order to assess what happens when the final state weighting matrix $\|\mathbf{S}\| \rightarrow \infty$, we first recall the Neumann series:

$$(\mathbb{I} - \mathbf{T})^{-1} = \sum_{k=0}^{\infty} \mathbf{T}^k \quad (2.32)$$

Applying this result to the right term of $\mathbf{P}_S(t)$ reads:

$$\begin{aligned} (\mathbf{Y}_1(t) + \mathbf{X}_1(t) \mathbf{S})^{-1} &= \left(\mathbb{I} + \left(\mathbf{Y}_1(t) (\mathbf{X}_1(t) \mathbf{S})^{-1} \right) \mathbf{X}_1(t) \mathbf{S} \right)^{-1} \\ &= (\mathbf{X}_1(t) \mathbf{S})^{-1} \left(\mathbb{I} + \mathbf{Y}_1(t) (\mathbf{X}_1(t) \mathbf{S})^{-1} \right)^{-1} \\ &= (\mathbf{X}_1(t) \mathbf{S})^{-1} \sum_{k=0}^{\infty} \left(-\mathbf{Y}_1(t) (\mathbf{X}_1(t) \mathbf{S})^{-1} \right)^k \\ &\approx (\mathbf{X}_1(t) \mathbf{S})^{-1} \left(\mathbb{I} - \mathbf{Y}_1(t) (\mathbf{X}_1(t) \mathbf{S})^{-1} \right) \\ &= \mathbf{S}^{-1} \mathbf{X}_1^{-1}(t) \left(\mathbb{I} - \mathbf{Y}_1(t) (\mathbf{X}_1(t) \mathbf{S})^{-1} \right) \end{aligned} \quad (2.33)$$

Thus $\mathbf{P}_S(t)$ can be approximated as follows when $\|\mathbf{S}\| \rightarrow \infty$:

$$\begin{aligned} \mathbf{P}_S(t) &\approx (\mathbf{Y}_2(t) + \mathbf{X}_2(t) \mathbf{S}) \mathbf{S}^{-1} \mathbf{X}_1^{-1}(t) \left(\mathbb{I} - \mathbf{Y}_1(t) (\mathbf{X}_1(t) \mathbf{S})^{-1} \right) \\ &\approx (\mathbf{Y}_2(t) \mathbf{S}^{-1} \mathbf{X}_1^{-1}(t) + \mathbf{X}_2(t) \mathbf{X}_1^{-1}(t)) \left(\mathbb{I} - \mathbf{Y}_1(t) (\mathbf{X}_1(t) \mathbf{S})^{-1} \right) \\ &\approx (\mathbf{Y}_2(t) \mathbf{S}^{-1} \mathbf{X}_1^{-1}(t) + \mathbf{X}_2(t) \mathbf{X}_1^{-1}(t)) \left(\mathbb{I} - \mathbf{Y}_1(t) \mathbf{S}^{-1} \mathbf{X}_1^{-1}(t) \right) \end{aligned} \quad (2.34)$$

When $\|\mathbf{S}\| \rightarrow \infty$ we retrieve the expression of $\mathbf{P}(t)$ in (2.24) by using the order 0 approximation of $\mathbf{P}_S(t)$. Indeed:

$$\|\mathbf{S}\| \rightarrow \infty \Rightarrow \mathbf{P}_S(t) \approx \mathbf{X}_2(t) \mathbf{X}_1^{-1}(t) \mathbb{I} = \mathbf{X}_2(t) \mathbf{X}_1^{-1}(t) = \mathbf{P}(t) \quad (2.35)$$

As far as $\mathbf{F}_S(t)$ is concerned, we also retrieve the expression of $\mathbf{F}(t)$ in (2.24)

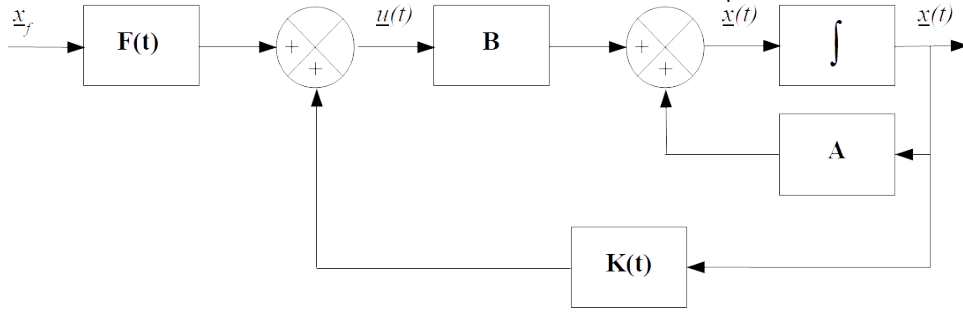

Figure 2.1: Finite horizon closed-loop optimal control

when $\|\mathbf{S}\| \rightarrow \infty$ by using the order 1 approximation of $\mathbf{P}_S(t)$. Indeed:

$$\begin{aligned}
 \|\mathbf{S}\| \rightarrow \infty &\Rightarrow \mathbf{P}_S(t) \mathbf{X}_1(t) \approx (\mathbf{Y}_2(t) \mathbf{S}^{-1} \mathbf{X}_1^{-1}(t) + \mathbf{X}_2(t) \mathbf{X}_1^{-1}(t)) (\mathbf{X}_1(t) - \mathbf{Y}_1(t) \mathbf{S}^{-1}) \\
 &\approx \mathbf{Y}_2(t) \mathbf{S}^{-1} + \mathbf{X}_2(t) - \mathbf{X}_2(t) \mathbf{X}_1^{-1}(t) \mathbf{Y}_1(t) \mathbf{S}^{-1} \\
 \Rightarrow \mathbf{X}_2(t) - \mathbf{P}_S(t) \mathbf{X}_1(t) &\approx \mathbf{X}_2(t) \mathbf{X}_1^{-1}(t) \mathbf{Y}_1(t) \mathbf{S}^{-1} - \mathbf{Y}_2(t) \mathbf{S}^{-1} \\
 \Rightarrow \mathbf{F}_S(t) &:= (\mathbf{X}_2(t) - \mathbf{P}_S(t) \mathbf{X}_1(t)) \mathbf{S} \\
 &\approx \mathbf{X}_2(t) \mathbf{X}_1^{-1}(t) \mathbf{Y}_1(t) - \mathbf{Y}_2(t) \\
 &= \mathbf{P}(t) \mathbf{Y}_1(t) - \mathbf{Y}_2(t) \\
 &= \mathbf{F}(t)
 \end{aligned} \tag{2.36}$$

2.4.5 Closed-loop block diagram

Finally, using (2.7), optimal control $\underline{u}(t)$ reads as follows when the final state is imposed (when the final state is weighted, $\mathbf{P}(t)$ and $\mathbf{F}(t)$ have to be replaced by $\mathbf{P}_S(t)$ and $\mathbf{F}_S(t)$, respectively):

$$\begin{aligned}
 \underline{u}(t) &= -\mathbf{R}^{-1} \mathbf{B}^T \underline{\lambda}(t) \\
 &= -\mathbf{R}^{-1} \mathbf{B}^T (\mathbf{P}(t) \underline{x}(t) - \mathbf{F}(t) \underline{x}_f) \\
 &:= -\mathbf{K}(t) \underline{x}(t) + \mathbf{F}(t) \underline{x}_f
 \end{aligned} \tag{2.37}$$

where:

$$\mathbf{K}(t) = \mathbf{R}^{-1} \mathbf{B}^T \mathbf{P}(t) \tag{2.38}$$

The preceding expression leads to the closed-loop block diagram shown in Figure 2.1.

It is worth noticing that $\mathbf{P}(t_f) = \mathbf{X}_2(t_f) \mathbf{X}_1^{-1}(t_f) \rightarrow \infty$ because $\mathbf{X}_1(t_f) = \mathbf{0}$ when the final value \underline{x}_f of $\underline{x}(t_f)$ is imposed, as indicated by (2.20). This is in line with the final value of $\mathbf{P}(t)$ as indicated by (2.10) when the final state is close to zero:

$$\underline{x}_f = \underline{0} \Rightarrow \underline{\lambda}(t_f) = \mathbf{P}(t_f) \underline{x}(t_f) = \mathbf{S} \underline{x}(t_f) \Rightarrow \mathbf{P}(t_f) = \mathbf{S} \tag{2.39}$$

Consequently, when it is desired that the final value $\underline{x}(t_f)$ tends towards \underline{x}_f , then $\mathbf{S} \rightarrow \infty$. Thus $\mathbf{S} = \mathbf{P}(t_f)$ is singular when the final value $\underline{x}(t_f)$ is set to \underline{x}_f . In that case, and to avoid the numerical difficulty when $t = t_f$, we shall set $\underline{u}(t_f) = \underline{0}$. Thus the optimal control reads:

$$\underline{u}(t) = \begin{cases} -\mathbf{K}(t) \underline{x}(t) + \mathbf{F}(t) \underline{x}_f & \forall 0 \leq t < t_f \\ \underline{0} & \text{for } t = t_f \end{cases} \tag{2.40}$$

2.5 Riccati differential equation

When the final value \underline{x}_f is set to zero, we have seen that the Lagrange multipliers $\underline{\lambda}(t)$ linearly depend on the state vector $\underline{x}(t)$ through the time dependent matrix $\mathbf{P}(t)$:

$$\underline{x}_f = \underline{0} \Rightarrow \underline{\lambda}(t) = \mathbf{P}(t)\underline{x}(t) \quad (2.41)$$

Using (2.9) and (2.10), we can compute the time derivative of the Lagrange multipliers $\underline{\lambda}(t) = \mathbf{P}(t)\underline{x}(t)$ as follows:

$$\begin{cases} \dot{\underline{\lambda}}(t) = \dot{\mathbf{P}}(t)\underline{x}(t) + \mathbf{P}(t)\dot{\underline{x}}(t) = -\mathbf{Q}\underline{x}(t) - \mathbf{A}^T\underline{\lambda}(t) \\ \underline{\lambda}(t_f) = \mathbf{P}(t_f)\underline{x}(t_f) = \mathbf{S}\underline{x}(t_f) \end{cases} \quad (2.42)$$

Then substituting (2.1), (2.7) and (2.41) within (2.42) we get:

$$\begin{aligned} & \begin{cases} \dot{\underline{x}} = \mathbf{A}\underline{x}(t) + \mathbf{B}\underline{u}(t) \\ \underline{u}(t) = -\mathbf{R}^{-1}\mathbf{B}^T\underline{\lambda}(t) \\ \underline{\lambda}(t) = \mathbf{P}(t)\underline{x}(t) \end{cases} \\ \Rightarrow & \begin{cases} \dot{\mathbf{P}}(t)\underline{x}(t) + \mathbf{P}(t)(\mathbf{A}\underline{x}(t) - \mathbf{B}\mathbf{R}^{-1}\mathbf{B}^T\mathbf{P}(t)\underline{x}(t)) = -\mathbf{Q}\underline{x}(t) - \mathbf{A}^T\mathbf{P}(t)\underline{x}(t) \\ \mathbf{P}(t_f)\underline{x}(t_f) = \mathbf{S}\underline{x}(t_f) \end{cases} \end{aligned} \quad (2.43)$$

Because the previous equation is true for all $\underline{x}(t)$ and $\underline{x}(t_f)$ we obtain the following equation, which is known as the *Riccati differential equation*:

$$\boxed{\begin{cases} \mathbf{A}^T\mathbf{P}(t) + \mathbf{P}(t)\mathbf{A} - \mathbf{P}(t)\mathbf{B}\mathbf{R}^{-1}\mathbf{B}^T\mathbf{P}(t) + \mathbf{Q} = -\dot{\mathbf{P}}(t) \\ \mathbf{P}(t_f) = \mathbf{S} \end{cases}} \quad (2.44)$$

From a computational point of view, the *Riccati differential equation* (2.44) may be integrated backward. The kernel $\mathbf{P}(t)$ is stored for each values of t and then is used to compute $\mathbf{K}(t)$ and $\underline{u}(t)$.

Alternatively, the analytic solution of the *Riccati differential equation* (2.44) is given either by $\mathbf{P}(t) := \mathbf{X}_2(t)\mathbf{X}_1^{-1}(t)$ in (2.24) when the final state $\underline{x}_f = \underline{0}$ is imposed or by $\mathbf{P}_S(t) := (\mathbf{Y}_2(t) + \mathbf{X}_2(t)\mathbf{S})(\mathbf{Y}_1(t) + \mathbf{X}_1(t)\mathbf{S})^{-1}$ in (2.30) when the final state $\underline{x}_f = \underline{0}$ is weighted by matrix $\mathbf{S} = \mathbf{S}^T \geq 0$. The key point to solve the *Riccati differential equation* is the partition of matrix $e^{\mathbf{H}(t-t_f)}$ shown in (2.18):

$$e^{\mathbf{H}(t-t_f)} := \begin{bmatrix} \mathbf{Y}_1(t) & \mathbf{X}_1(t) \\ \mathbf{Y}_2(t) & \mathbf{X}_2(t) \end{bmatrix} \quad (2.45)$$

It is worth noticing that the Riccati differential equation can be written in a compact form as follows where \mathbf{H} denotes the Hamiltonian matrix defined in (2.13):

$$\begin{aligned} -\dot{\mathbf{P}}(t) &= \mathbf{A}^T\mathbf{P}(t) + \mathbf{P}(t)\mathbf{A} - \mathbf{P}(t)\mathbf{B}\mathbf{R}^{-1}\mathbf{B}^T\mathbf{P}(t) + \mathbf{Q} \\ \Leftrightarrow -\dot{\mathbf{P}}(t) &= \begin{bmatrix} \mathbf{P}(t) & -\mathbb{I}_n \end{bmatrix} \mathbf{H} \begin{bmatrix} \mathbb{I}_n \\ \mathbf{P}(t) \end{bmatrix} \end{aligned} \quad (2.46)$$

2.6 Examples

2.6.1 Example 1

Given the following scalar plant:

$$\begin{cases} \dot{x}(t) = ax(t) + bu(t) \\ x(0) = x_0 \end{cases} \quad (2.47)$$

Find control $u(t)$ which minimizes the following performance index where $x_f = 0$, $S \geq 0$ and $\rho > 0$:

$$J(u(t)) = \frac{1}{2}x^T(t_f)Sx(t_f) + \frac{1}{2} \int_0^{t_f} \rho u^2(t) dt \quad (2.48)$$

Hamiltonian matrix \mathbf{H} defined in (2.13) reads:

$$\mathbf{H} = \begin{bmatrix} \mathbf{A} & -\mathbf{B}\mathbf{R}^{-1}\mathbf{B}^T \\ -\mathbf{Q} & -\mathbf{A}^T \end{bmatrix} = \begin{bmatrix} a & \frac{-b^2}{\rho} \\ 0 & -a \end{bmatrix} \quad (2.49)$$

Denoting by s the Laplace variable, the exponential of matrix $e^{\mathbf{H}t}$ is obtained thanks to the inverse of the Laplace transform, which is denoted \mathcal{L}^{-1} :

$$\begin{aligned} e^{\mathbf{H}t} &= \mathcal{L}^{-1} \left((sI - \mathbf{H})^{-1} \right) = \mathcal{L}^{-1} \left(\begin{bmatrix} s-a & b^2/\rho \\ 0 & s+a \end{bmatrix}^{-1} \right) \\ &= \mathcal{L}^{-1} \left(\frac{1}{(s-a)(s+a)} \begin{bmatrix} s+a & -b^2/\rho \\ 0 & s-a \end{bmatrix} \right) \\ &= \mathcal{L}^{-1} \left(\begin{bmatrix} \frac{1}{s-a} & \frac{-b^2}{\rho(s^2-a^2)} \\ 0 & \frac{1}{s+a} \end{bmatrix} \right) \\ &= \begin{bmatrix} e^{at} & \frac{-b^2(e^{at}-e^{-at})}{2\rho a} \\ 0 & e^{-at} \end{bmatrix} \end{aligned} \quad (2.50)$$

Following (2.18), the partition of $e^{\mathbf{H}(t-t_f)}$ reads:

$$e^{\mathbf{H}(t-t_f)} = \begin{bmatrix} e^{a(t-t_f)} & \frac{-b^2(e^{a(t-t_f)}-e^{-a(t-t_f)})}{2\rho a} \\ 0 & e^{-a(t-t_f)} \end{bmatrix} := \begin{bmatrix} \mathbf{Y}_1(t) & \mathbf{X}_1(t) \\ \mathbf{Y}_2(t) & \mathbf{X}_2(t) \end{bmatrix} \quad (2.51)$$

Because the final state $\underline{x}_f = \underline{0}$ is weighted by matrix $S \geq 0$, we finally get the solution of the Riccati differential equation thanks to $\mathbf{P}_S(t)$ in (2.30):

$$\begin{aligned} \mathbf{P}_S(t) &:= (\mathbf{Y}_2(t) + \mathbf{X}_2(t)\mathbf{S}) (\mathbf{Y}_1(t) + \mathbf{X}_1(t)\mathbf{S})^{-1} \\ &= e^{-a(t-t_f)} S \left(e^{a(t-t_f)} + \frac{-b^2(e^{a(t-t_f)}-e^{-a(t-t_f)})}{2\rho a} S \right)^{-1} \\ &= \frac{S e^{-a(t-t_f)}}{e^{a(t-t_f)} \frac{S b^2 (e^{a(t-t_f)} - e^{-a(t-t_f)})}{2\rho a}} \\ &= \frac{S}{e^{2a(t-t_f)} + \frac{S b^2 (1 - e^{-2a(t-t_f)})}{2\rho a}} \end{aligned} \quad (2.52)$$

Finally the optimal control reads:

$$\begin{aligned}
u(t) &= -\mathbf{K}(t)x(t) \\
&= -\mathbf{R}^{-1}\mathbf{B}^T\mathbf{P}_S(t)x(t) \\
&= -\frac{b}{\rho}\mathbf{P}_S(t)x(t) \\
&= \frac{-bS}{\rho e^{2a(t-t_f)} + \frac{Sb^2(1-e^{2a(t-t_f)})}{2a}}x(t)
\end{aligned} \tag{2.53}$$

If we want to ensure that the optimal control drives $x(t_f)$ exactly to $x_f = 0$, we let $S \rightarrow \infty$ to weight heavily $x(t_f)$ in the performance index $J(u(t))$. Then:

$$\mathbf{P}_S(t) \xrightarrow[S \rightarrow \infty]{} \mathbf{P}(t) = \mathbf{X}_2(t)\mathbf{X}_1^{-1}(t) = \frac{2\rho a}{b^2(1-e^{2a(t-t_f)})} \tag{2.54}$$

and:

$$u(t) = -\mathbf{R}^{-1}\mathbf{B}^T\mathbf{P}(t)x(t) = \frac{-2a}{b(1-e^{2a(t-t_f)})}x(t) \tag{2.55}$$

2.6.2 Example 2

Given the following plant, which actually represents a double integrator:

$$\begin{bmatrix} \dot{x}_1(t) \\ \dot{x}_2(t) \end{bmatrix} = \begin{bmatrix} 0 & 1 \\ 0 & 0 \end{bmatrix} \begin{bmatrix} x_1(t) \\ x_2(t) \end{bmatrix} + \begin{bmatrix} 0 \\ 1 \end{bmatrix} \underline{u}(t) \tag{2.56}$$

Find control $\underline{u}(t)$ which minimizes the following performance index where $\underline{x}_f = \underline{0}$ and $\mathbf{S} = \mathbf{S}^T \geq 0$:

$$J(\underline{u}(t)) = \frac{1}{2}\underline{x}^T(t_f)\mathbf{S}\underline{x}(t_f) + \frac{1}{2}\int_0^{t_f} \underline{u}^2(t)dt \tag{2.57}$$

Weighting matrix \mathbf{S} reads as follows:

$$\mathbf{S} = \mathbf{S}^T = \begin{bmatrix} s_p & 0 \\ 0 & s_v \end{bmatrix} \geq 0 \tag{2.58}$$

Hamiltonian matrix \mathbf{H} defined in (2.13) reads:

$$\mathbf{H} = \begin{bmatrix} \mathbf{A} & -\mathbf{B}\mathbf{R}^{-1}\mathbf{B}^T \\ -\mathbf{Q} & -\mathbf{A}^T \end{bmatrix} = \begin{bmatrix} 0 & 1 & 0 & 0 \\ 0 & 0 & 0 & -1 \\ 0 & 0 & 0 & 0 \\ 0 & 0 & -1 & 0 \end{bmatrix} \tag{2.59}$$

In order to compute $e^{\mathbf{H}t}$ we use the following relation where \mathcal{L}^{-1} stands for the inverse Laplace transform:

$$e^{\mathbf{H}t} = \mathcal{L}^{-1} \left[(s\mathbb{I} - \mathbf{H})^{-1} \right] \tag{2.60}$$

We get:

$$\begin{aligned}
s\mathbb{I} - \mathbf{H} &= \begin{bmatrix} s & -1 & 0 & 0 \\ 0 & s & 0 & 1 \\ 0 & 0 & s & 0 \\ 0 & 0 & 1 & s \end{bmatrix} \Rightarrow (s\mathbb{I} - \mathbf{H})^{-1} = \begin{bmatrix} \frac{1}{s} & \frac{1}{s^2} & \frac{1}{s^4} & -\frac{1}{s^3} \\ 0 & \frac{1}{s} & \frac{1}{s^3} & -\frac{1}{s^2} \\ 0 & 0 & \frac{1}{s} & 0 \\ 0 & 0 & -\frac{1}{s^2} & \frac{1}{s} \end{bmatrix} \\
\Rightarrow e^{\mathbf{H}t} = \mathcal{L}^{-1} \left[(s\mathbb{I} - \mathbf{H})^{-1} \right] &= \begin{bmatrix} 1 & t & \frac{t^3}{6} & -\frac{t^2}{2} \\ 0 & 1 & \frac{t^2}{2} & -t \\ 0 & 0 & 1 & 0 \\ 0 & 0 & -t & 1 \end{bmatrix}
\end{aligned} \tag{2.61}$$

Following (2.18), the partition of $e^{\mathbf{H}(t-t_f)}$ reads:

$$e^{\mathbf{H}(t-t_f)} = \begin{bmatrix} 1 & (t-t_f) & \frac{(t-t_f)^3}{6} & -\frac{(t-t_f)^2}{2} \\ 0 & 1 & \frac{(t-t_f)^2}{2} & -(t-t_f) \\ 0 & 0 & 1 & 0 \\ 0 & 0 & -(t-t_f) & 1 \end{bmatrix} := \begin{bmatrix} \mathbf{Y}_1(t) & \mathbf{X}_1(t) \\ \mathbf{Y}_2(t) & \mathbf{X}_2(t) \end{bmatrix} \tag{2.62}$$

Because the final state $\underline{x}_f = \underline{0}$ is weighted by matrix $\mathbf{S} \geq 0$, we finally get the solution of the Riccati differential equation thanks to $\mathbf{P}_S(t)$ in (2.30):

$$\begin{aligned}
\mathbf{P}_S(t) &:= (\mathbf{Y}_2(t) + \mathbf{X}_2(t) \mathbf{S}) (\mathbf{Y}_1(t) + \mathbf{X}_1(t) \mathbf{S})^{-1} \\
&= \begin{bmatrix} s_p & 0 \\ -s_p(t-t_f) & s_v \end{bmatrix} \begin{bmatrix} 1 + s_p \frac{(t-t_f)^3}{6} & t-t_f - s_v \frac{(t-t_f)^2}{2} \\ s_p \frac{(t-t_f)^2}{2} & 1 - s_v(t-t_f) \end{bmatrix}^{-1} \\
&= \frac{1}{\Delta} \begin{bmatrix} s_p & 0 \\ -s_p(t-t_f) & s_v \end{bmatrix} \begin{bmatrix} 1 - s_v(t-t_f) & t_f - t + s_v \frac{(t-t_f)^2}{2} \\ -s_p \frac{(t-t_f)^2}{2} & 1 + s_p \frac{(t-t_f)^3}{6} \end{bmatrix}
\end{aligned} \tag{2.63}$$

where:

$$\Delta = \left(1 + s_p \frac{(t-t_f)^3}{6} \right) (1 - s_v(t-t_f)) - s_p \frac{(t-t_f)^2}{2} \left(t-t_f - s_v \frac{(t-t_f)^2}{2} \right) \tag{2.64}$$

2.7 Second order necessary condition for optimality

It is worth noticing that the second order necessary condition for optimality to achieve a minimum cost is the positive semi-definiteness of the Hessian matrix of the Hamiltonian along an optimal trajectory (see (1.214)). This condition is always satisfied as soon as $\mathbf{R} > 0$. Indeed we get from (2.6):

$$\frac{\partial^2 H}{\partial u^2} = \mathbf{H}_{uu} = \mathbf{R} > 0 \tag{2.65}$$

2.8 Minimum cost achieved

The minimum cost achieved is given by:

$$J^* = J(\underline{u}^*(t)) = \frac{1}{2} \underline{x}^T(0) \mathbf{P}(0) \underline{x}(0) \tag{2.66}$$

Indeed, from the Riccati equation (2.44), we deduce that:

$$\begin{aligned}
& \underline{x}^T \left(\dot{\mathbf{P}} + \mathbf{P}\mathbf{A} + \mathbf{A}^T\mathbf{P} - \mathbf{P}\mathbf{B}\mathbf{R}^{-1}\mathbf{B}^T\mathbf{P} + \mathbf{Q} \right) \underline{x} = 0 \\
& \Leftrightarrow \underline{x}^T \dot{\mathbf{P}}\underline{x} + \underline{x}^T \mathbf{P}\mathbf{A}\underline{x} + \underline{x}^T \mathbf{A}^T\mathbf{P}\underline{x} - \underline{x}^T \mathbf{P}\mathbf{B}\mathbf{R}^{-1}\mathbf{B}^T\mathbf{P}\underline{x} + \underline{x}^T \mathbf{Q}\underline{x} = 0 \quad (2.67) \\
& \Leftrightarrow \underline{x}^T \dot{\mathbf{P}}\underline{x} + \underline{x}^T \mathbf{P}\mathbf{A}\underline{x} + (\underline{x}^T \mathbf{P}\mathbf{A}\underline{x})^T - \underline{x}^T \mathbf{P}\mathbf{B}\mathbf{R}^{-1}\mathbf{B}^T\mathbf{P}\underline{x} + \underline{x}^T \mathbf{Q}\underline{x} = 0
\end{aligned}$$

Taking into account the fact that $\mathbf{P} = \mathbf{P}^T > 0$, $\mathbf{R} = \mathbf{R}^T > 0$ as well as (2.1), (2.37) with $\underline{x}_f = \underline{0}$ and (2.38) it can be shown that:

$$\left\{ \begin{array}{l}
\underline{x}^T \mathbf{P}\mathbf{B}\mathbf{R}^{-1}\mathbf{B}^T\mathbf{P}\underline{x} = -\underline{x}^T \mathbf{P}\mathbf{B}\underline{u}^* \\
= -\underline{x}^T \mathbf{P}\mathbf{B}\mathbf{R}^{-1}\mathbf{R}\underline{u}^* \\
= \underline{u}^{*T} \mathbf{R}\underline{u}^* \\
\underline{x}^T \mathbf{P}\mathbf{A}\underline{x} = \underline{x}^T \mathbf{P}(\mathbf{A}\underline{x} + \mathbf{B}\underline{u}^* - \mathbf{B}\underline{u}^*) \\
= \underline{x}^T \mathbf{P}\dot{\underline{x}} - \underline{x}^T \mathbf{P}\mathbf{B}\underline{u}^* \\
= \underline{x}^T \dot{\mathbf{P}}\underline{x} + \underline{u}^{*T} \mathbf{R}\underline{u}^* \\
\Rightarrow \underline{x}^T \dot{\mathbf{P}}\underline{x} + \underline{x}^T \mathbf{P}\mathbf{A}\underline{x} + (\underline{x}^T \mathbf{P}\mathbf{A}\underline{x})^T - \underline{x}^T \mathbf{P}\mathbf{B}\mathbf{R}^{-1}\mathbf{B}^T\mathbf{P}\underline{x} \\
= \underline{x}^T \dot{\mathbf{P}}\underline{x} + \underline{x}^T \mathbf{P}\dot{\underline{x}} + \dot{\underline{x}}^T \mathbf{P}\underline{x} + \underline{u}^{*T} \mathbf{R}\underline{u}^* \\
= \frac{d}{dt} (\underline{x}^T \mathbf{P}\underline{x}) + \underline{u}^{*T} \mathbf{R}\underline{u}^*
\end{array} \right. \quad (2.68)$$

As a consequence equation (2.67) can be written as follows:

$$\frac{d}{dt} (\underline{x}^T(t)\mathbf{P}(t)\underline{x}(t)) + \underline{x}^T(t)\mathbf{Q}\underline{x}(t) + \underline{u}^{*T}(t)\mathbf{R}\underline{u}^*(t) = 0 \quad (2.69)$$

And the performance index (2.2) to be minimized can be re-written as:

$$\begin{aligned}
J(\underline{u}^*(t)) &= \frac{1}{2} \underline{x}^T(t_f) \mathbf{S} \underline{x}(t_f) + \frac{1}{2} \int_0^{t_f} \underline{x}^T(t) \mathbf{Q} \underline{x}(t) + \underline{u}^{*T}(t) \mathbf{R} \underline{u}^*(t) dt \\
&\Leftrightarrow J(\underline{u}^*(t)) = \frac{1}{2} \left(\underline{x}^T(t_f) \mathbf{S} \underline{x}(t_f) - \int_0^{t_f} \frac{d}{dt} (\underline{x}^T(t) \mathbf{P}(t) \underline{x}(t)) dt \right) \quad (2.70) \\
&\Leftrightarrow J(\underline{u}^*(t)) = \frac{1}{2} (\underline{x}^T(t_f) \mathbf{S} \underline{x}(t_f) - \underline{x}^T(t_f) \mathbf{P}(t_f) \underline{x}(t_f) + \underline{x}^T(0) \mathbf{P}(0) \underline{x}(0))
\end{aligned}$$

Then taking into account the boundary conditions $\mathbf{P}(t_f) = \mathbf{S}$ we finally get (2.66).

2.9 Application to minimum energy control problem

Minimum energy control problem appears when $\mathbf{Q} := \mathbf{0}$.

2.9.1 Moving a linear system close to a final state with minimum energy

Let's consider the following dynamical system:

$$\dot{\underline{x}}(t) = \mathbf{A}\underline{x}(t) + \mathbf{B}\underline{u}(t) \quad (2.71)$$

We are looking for the control $\underline{u}(t)$ which moves the system from the initial state $\underline{x}(0) = \underline{x}_0$ to a final state which should be close to a given value $\underline{x}(t_f) = \underline{x}_f$ at final time $t = t_f$. We will assume that the performance index to be minimized

is the following quadratic performance index where \mathbf{R} is a symmetric positive definite matrix:

$$J(\underline{u}(t)) = \frac{1}{2} (\underline{x}(t_f) - \underline{x}_f)^T \mathbf{S} (\underline{x}(t_f) - \underline{x}_f) + \frac{1}{2} \int_0^{t_f} \underline{u}^T(t) \mathbf{R} \underline{u}(t) dt \quad (2.72)$$

For this optimal control problem, the Hamiltonian (2.5) is:

$$H(\underline{x}, \underline{u}, \underline{\lambda}) = \frac{1}{2} \underline{u}^T(t) \mathbf{R} \underline{u}(t) + \underline{\lambda}^T(t) (\mathbf{A} \underline{x}(t) + \mathbf{B} \underline{u}(t)) \quad (2.73)$$

The necessary condition for optimality (2.6) yields:

$$\frac{\partial H}{\partial \underline{u}} = \mathbf{R} \underline{u}(t) + \mathbf{B}^T \underline{\lambda}(t) = 0 \quad (2.74)$$

We get:

$$\underline{u}(t) = -\mathbf{R}^{-1} \mathbf{B}^T \underline{\lambda}(t) \quad (2.75)$$

Eliminating $\underline{u}(t)$ in equation (2.72) reads:

$$\dot{\underline{x}}(t) = \mathbf{A} \underline{x}(t) - \mathbf{B} \mathbf{R}^{-1} \mathbf{B}^T \underline{\lambda}(t) \quad (2.76)$$

The dynamics of Lagrange multipliers $\underline{\lambda}(t)$ is given by (2.9):

$$\dot{\underline{\lambda}}(t) = -\frac{\partial H}{\partial \underline{x}} = -\mathbf{A}^T \underline{\lambda}(t) \quad (2.77)$$

We get from the preceding equation:

$$\underline{\lambda}(t) = e^{-\mathbf{A}^T t} \underline{\lambda}(0) \quad (2.78)$$

The value of $\underline{\lambda}(0)$ will influence the final value of the state vector $\underline{x}(t)$. Indeed let's integrate the linear differential equation:

$$\dot{\underline{x}}(t) = \mathbf{A} \underline{x}(t) - \mathbf{B} \mathbf{R}^{-1} \mathbf{B}^T \underline{\lambda}(t) = \mathbf{A} \underline{x}(t) + \mathbf{B} \mathbf{R}^{-1} \mathbf{B}^T e^{-\mathbf{A}^T t} \underline{\lambda}(0) \quad (2.79)$$

This leads to the following expression of the state vector $\underline{x}(t)$:

$$\begin{aligned} \underline{x}(t) &= e^{\mathbf{A}t} \underline{x}_0 + e^{\mathbf{A}t} \int_0^t e^{-\mathbf{A}\tau} \mathbf{B} \mathbf{R}^{-1} \mathbf{B}^T e^{-\mathbf{A}^T \tau} \underline{\lambda}(0) d\tau \\ &= e^{\mathbf{A}t} \underline{x}_0 + e^{\mathbf{A}t} \left(\int_0^t e^{-\mathbf{A}\tau} \mathbf{B} \mathbf{R}^{-1} \mathbf{B}^T e^{-\mathbf{A}^T \tau} d\tau \right) \underline{\lambda}(0) \end{aligned} \quad (2.80)$$

Or:

$$\underline{x}(t) = e^{\mathbf{A}t} \underline{x}_0 + e^{\mathbf{A}t} \mathbf{W}_c(t) \underline{\lambda}(0) \quad (2.81)$$

where matrix $\mathbf{W}_c(t)$ is defined as follows:

$$\mathbf{W}_c(t) = \int_0^t e^{-\mathbf{A}\tau} \mathbf{B} \mathbf{R}^{-1} \mathbf{B}^T e^{-\mathbf{A}^T \tau} d\tau \quad (2.82)$$

Now using (2.10) we set $\underline{\lambda}(t_f)$ as follows:

$$\underline{\lambda}(t_f) = \mathbf{S} (\underline{x}(t_f) - \underline{x}_f) \quad (2.83)$$

Using (2.78) and (2.81) we get:

$$\begin{cases} \underline{\lambda}(t_f) = e^{-\mathbf{A}^T t_f} \underline{\lambda}(0) \\ \underline{x}(t_f) = e^{\mathbf{A} t_f} \underline{x}_0 + e^{\mathbf{A} t_f} \mathbf{W}_c(t_f) \underline{\lambda}(0) \end{cases} \quad (2.84)$$

And the transversality condition (2.83) is rewritten as follows:

$$\begin{aligned} \underline{\lambda}(t_f) &= \mathbf{S} (\underline{x}(t_f) - \underline{x}_f) \\ \Leftrightarrow e^{-\mathbf{A}^T t_f} \underline{\lambda}(0) &= \mathbf{S} (e^{\mathbf{A} t_f} \underline{x}_0 + e^{\mathbf{A} t_f} \mathbf{W}_c(t_f) \underline{\lambda}(0) - \underline{x}_f) \end{aligned} \quad (2.85)$$

Solving the preceding linear equation in $\underline{\lambda}(0)$ gives the following expression:

$$\begin{aligned} \left(e^{-\mathbf{A}^T t_f} - \mathbf{S} e^{\mathbf{A} t_f} \mathbf{W}_c(t_f) \right) \underline{\lambda}(0) &= \mathbf{S} (e^{\mathbf{A} t_f} \underline{x}_0 - \underline{x}_f) \\ \Leftrightarrow \underline{\lambda}(0) &= \left(e^{-\mathbf{A}^T t_f} - \mathbf{S} e^{\mathbf{A} t_f} \mathbf{W}_c(t_f) \right)^{-1} \mathbf{S} (e^{\mathbf{A} t_f} \underline{x}_0 - \underline{x}_f) \end{aligned} \quad (2.86)$$

Using the expression of $\underline{\lambda}(0)$ in (2.78) leads to the expression of the Lagrange multiplier $\underline{\lambda}(t)$:

$$\underline{\lambda}(t) = e^{-\mathbf{A}^T t} \left(e^{-\mathbf{A}^T t_f} - \mathbf{S} e^{\mathbf{A} t_f} \mathbf{W}_c(t_f) \right)^{-1} \mathbf{S} (e^{\mathbf{A} t_f} \underline{x}_0 - \underline{x}_f) \quad (2.87)$$

Finally control $\underline{u}(t)$ is obtained thanks equation (2.75):

$$\underline{u}(t) = -\mathbf{R}^{-1} \mathbf{B}^T \underline{\lambda}(t) \quad (2.88)$$

It is clear from the expression of $\underline{\lambda}(t)$ that the control $\underline{u}(t)$ explicitly depends on the initial state \underline{x}_0 .

2.9.2 Moving a linear system exactly to a final state with minimum energy

We are now looking for the control $\underline{u}(t)$ which moves the system from the initial state $\underline{x}(0) = \underline{x}_0$ to a given final state $\underline{x}(t_f) = \underline{x}_f$ at final time $t = t_f$. We will assume that the performance index to be minimized is the following quadratic performance index where \mathbf{R} is a symmetric positive definite matrix:

$$J = \frac{1}{2} \int_0^{t_f} \underline{u}^T(t) \mathbf{R} \underline{u}(t) dt \quad (2.89)$$

To solve this problem the same reasoning applies than in the previous example. As far as control $\underline{u}(t)$ is concerned this leads to equation (2.75). The change is that now the final value of the state vector $\underline{x}(t)$ is imposed to be $\underline{x}(t_f) = \underline{x}_f$. So there is no final value for the Lagrange multipliers. Indeed $\underline{\lambda}(t_f)$, or equivalently $\underline{\lambda}(0)$, has to be set such that $\underline{x}(t_f) = \underline{x}_f$. We have seen in (2.81) that the state vector $\underline{x}(t)$ has the following expression:

$$\underline{x}(t) = e^{\mathbf{A} t} \underline{x}_0 + e^{\mathbf{A} t} \mathbf{W}_c(t) \underline{\lambda}(0) \quad (2.90)$$

where matrix $\mathbf{W}_c(t)$ is defined as follows:

$$\mathbf{W}_c(t) = \int_0^t e^{-\mathbf{A} \tau} \mathbf{B} \mathbf{R}^{-1} \mathbf{B}^T e^{-\mathbf{A}^T \tau} d\tau \quad (2.91)$$

Then we set $\underline{\lambda}(0)$ as follows where \underline{c}_0 is a constant vector:

$$\underline{\lambda}(0) = \mathbf{W}_c^{-1}(t_f)\underline{c}_0 \quad (2.92)$$

We get:

$$\underline{x}(t) = e^{\mathbf{A}t}\underline{x}_0 + e^{\mathbf{A}t}\mathbf{W}_c(t)\mathbf{W}_c^{-1}(t_f)\underline{c}_0 \quad (2.93)$$

Constant vector \underline{c}_0 is used to satisfy the final value on the state vector $\underline{x}(t)$. Setting $\underline{x}(t_f) = \underline{x}_f$ leads to the value of constant vector \underline{c}_0 :

$$\underline{x}(t_f) = \underline{x}_f \Rightarrow \underline{c}_0 = e^{-\mathbf{A}t_f}\underline{x}_f - \underline{x}_0 \quad (2.94)$$

Thus:

$$\underline{\lambda}(0) = \mathbf{W}_c^{-1}(t_f)(e^{-\mathbf{A}t_f}\underline{x}_f - \underline{x}_0) \quad (2.95)$$

Using (2.95) in (2.78) leads to the expression of the Lagrange multiplier $\underline{\lambda}(t)$:

$$\begin{aligned} \underline{\lambda}(t) &= e^{-\mathbf{A}^T t}\underline{\lambda}(0) \\ &= e^{-\mathbf{A}^T t}\mathbf{W}_c^{-1}(t_f)(e^{-\mathbf{A}t_f}\underline{x}_f - \underline{x}_0) \end{aligned} \quad (2.96)$$

Finally the control $\underline{u}(t)$ which moves with the minimum energy the system from the initial state $\underline{x}(0) = \underline{x}_0$ to a given final state $\underline{x}(t_f) = \underline{x}_f$ at final time $t = t_f$ has the following expression:

$$\begin{aligned} \underline{u}(t) &= -\mathbf{R}^{-1}\mathbf{B}^T\underline{\lambda}(t) \\ &= -\mathbf{R}^{-1}\mathbf{B}^T e^{-\mathbf{A}^T t}\underline{\lambda}(0) \\ &= -\mathbf{R}^{-1}\mathbf{B}^T e^{-\mathbf{A}^T t}\mathbf{W}_c^{-1}(t_f)(e^{-\mathbf{A}t_f}\underline{x}_f - \underline{x}_0) \end{aligned} \quad (2.97)$$

It is clear from the preceding expression that the control $\underline{u}(t)$ explicitly depends on the initial state \underline{x}_0 . When comparing the initial value $\underline{\lambda}(0)$ of the Lagrange multiplier obtained in (2.95) in the case where the final state is imposed to be $\underline{x}(t_f) = \underline{x}_f$ with the expression of the initial value of the Lagrange multiplier obtained in (2.86) in the case where the final state $\underline{x}(t_f)$ is close to a given final state \underline{x}_f we can see that the expression in (2.95) corresponds to the limit of the initial value (2.86) when matrix \mathbf{S} moves towards infinity (note that $(e^{\mathbf{A}t_f})^{-1} = e^{-\mathbf{A}t_f}$):

$$\begin{aligned} \lim_{\mathbf{S} \rightarrow \infty} & \left(e^{-\mathbf{A}^T t_f} - \mathbf{S}e^{\mathbf{A}t_f}\mathbf{W}_c(t_f) \right)^{-1} \mathbf{S} (e^{\mathbf{A}t_f}\underline{x}_0 - \underline{x}_f) \\ &= \lim_{\mathbf{S} \rightarrow \infty} \left(-\mathbf{S}e^{\mathbf{A}t_f}\mathbf{W}_c(t_f) \right)^{-1} \mathbf{S} (e^{\mathbf{A}t_f}\underline{x}_0 - \underline{x}_f) \\ &= \lim_{\mathbf{S} \rightarrow \infty} \mathbf{W}_c^{-1}(t_f)e^{-\mathbf{A}t_f}\mathbf{S}^{-1}\mathbf{S} (e^{\mathbf{A}t_f}\underline{x}_0 - \underline{x}_f) \\ &= \mathbf{W}_c^{-1}(t_f)e^{-\mathbf{A}t_f} (e^{\mathbf{A}t_f}\underline{x}_0 - \underline{x}_f) \end{aligned} \quad (2.98)$$

2.9.3 Example

Given the following scalar plant:

$$\begin{cases} \dot{x}(t) = ax(t) + bu(t) \\ x(0) = x_0 \end{cases} \quad (2.99)$$

Find the optimal control for the following cost functional and final states constraints:

We wish to compute a finite horizon Linear Quadratic Regulator with either a fixed or a weighted final state x_f .

- When the final state $x(t_f)$ is set to a fixed value x_f and the cost functional is set to:

$$J = \frac{1}{2} \int_0^{t_f} \rho u^2(t) dt \quad (2.100)$$

- When the final state $x(t_f)$ shall be close of a fixed value x_f so that the cost functional is modified as follows where is a positive scalar ($\mathbf{S} > 0$):

$$J = \frac{1}{2} (x(t_f) - x_f)^T \mathbf{S} (x(t_f) - x_f) + \frac{1}{2} \int_0^{t_f} \rho u^2(t) dt \quad (2.101)$$

In both cases the two-point boundary value problem which shall be solved depends on the solution of the following differential equation where Hamiltonian matrix \mathbf{H} appears:

$$\begin{bmatrix} \dot{x}(t) \\ \dot{\lambda}(t) \end{bmatrix} = \begin{bmatrix} \mathbf{A} & -\mathbf{B}\mathbf{R}^{-1}\mathbf{B}^T \\ -\mathbf{Q} & -\mathbf{A}^T \end{bmatrix} \begin{bmatrix} x(t) \\ \lambda(t) \end{bmatrix} = \begin{bmatrix} a & -b^2/\rho \\ 0 & -a \end{bmatrix} \begin{bmatrix} x(t) \\ \lambda(t) \end{bmatrix} = \mathbf{H} \begin{bmatrix} x(t) \\ \lambda(t) \end{bmatrix} \quad (2.102)$$

The solution of this differential equation reads:

$$\begin{bmatrix} x(t) \\ \lambda(t) \end{bmatrix} = e^{\mathbf{H}t} \begin{bmatrix} x(0) \\ \lambda(0) \end{bmatrix} \quad (2.103)$$

Denoting by s the Laplace variable, the exponential of matrix $\mathbf{H}t$ is obtained thanks to the inverse of the Laplace transform denoted \mathcal{L}^{-1} :

$$\begin{aligned} e^{\mathbf{H}t} &= \mathcal{L}^{-1} \left((s\mathbb{I} - \mathbf{H})^{-1} \right) \\ &= \mathcal{L}^{-1} \left(\begin{bmatrix} s-a & b^2/\rho \\ 0 & s+a \end{bmatrix}^{-1} \right) \\ &= \mathcal{L}^{-1} \left(\frac{1}{(s-a)(s+a)} \begin{bmatrix} s+a & -b^2/\rho \\ 0 & s-a \end{bmatrix} \right) \\ &= \mathcal{L}^{-1} \left(\begin{bmatrix} \frac{1}{s-a} & \frac{-b^2}{\rho(s^2-a^2)} \\ 0 & \frac{1}{s+a} \end{bmatrix} \right) \\ \Leftrightarrow e^{\mathbf{H}t} &= \begin{bmatrix} e^{at} & \frac{-b^2(e^{at}-e^{-at})}{2\rho a} \\ 0 & e^{-at} \end{bmatrix} \end{aligned} \quad (2.104)$$

That is:

$$\begin{bmatrix} x(t) \\ \lambda(t) \end{bmatrix} = e^{\mathbf{H}t} \begin{bmatrix} x(0) \\ \lambda(0) \end{bmatrix} = \begin{bmatrix} e^{at} & \frac{-b^2(e^{at}-e^{-at})}{2\rho a} \\ 0 & e^{-at} \end{bmatrix} \begin{bmatrix} x(0) \\ \lambda(0) \end{bmatrix} \quad (2.105)$$

- If the final state $x(t_f)$ is set to the value x_f then the value $\lambda(0)$ is obtained by solving the first equation of (2.105):

$$\begin{aligned} x(t_f) = x_f &= e^{at_f} x(0) - \frac{b^2(e^{at_f}-e^{-at_f})}{2\rho a} \lambda(0) \\ \Rightarrow \lambda(0) &= \frac{-2\rho a}{b^2(e^{at_f}-e^{-at_f})} (x_f - e^{at_f} x(0)) \end{aligned} \quad (2.106)$$

And:

$$\begin{cases} x(t) &= e^{at}x(0) + \frac{e^{at}-e^{-at}}{e^{at_f}-e^{-at_f}} (x_f - e^{at_f}x(0)) \\ \lambda(t) &= e^{-at}\lambda(0) = \frac{-2\rho ae^{-at}}{b^2(e^{at_f}-e^{-at_f})} (x_f - e^{at_f}x(0)) \end{cases} \quad (2.107)$$

The optimal control $u(t)$ is given by:

$$u(t) = -\mathbf{R}^{-1}\mathbf{B}^T\lambda(t) = \frac{-b}{\rho}\lambda(t) = \frac{2ae^{-at}}{b(e^{at_f}-e^{-at_f})} (x_f - e^{at_f}x(0)) \quad (2.108)$$

Interestingly enough, the open-loop control is independent of the control weighting ρ .

- If the final state $x(t_f)$ is expected to be close to the final value x_f then we have to mix the two equations of (2.105) and the constraint $\lambda(t_f) = \mathbf{S}(x(t_f) - x_f)$ to compute the value of $\lambda(0)$:

$$\begin{aligned} \lambda(t_f) &= \mathbf{S}(x(t_f) - x_f) \\ \Rightarrow e^{-at_f}\lambda(0) &= \mathbf{S}\left(e^{at_f}x(0) - \frac{b^2(e^{at_f}-e^{-at_f})}{2\rho a}\lambda(0) - x_f\right) \\ \Leftrightarrow \lambda(0) &= \frac{\mathbf{S}(e^{at_f}x(0)-x_f)}{e^{-at_f} + \frac{\mathbf{S}b^2(e^{at_f}-e^{-at_f})}{2\rho a}} \end{aligned} \quad (2.109)$$

Obviously, when $\mathbf{S} \rightarrow \infty$ we obtain for $\lambda(0)$ the same expression than (2.106).

2.10 Finite horizon LQ regulator with cross-term in the performance index

Consider the following time invariant state differential equation:

$$\begin{cases} \dot{\underline{x}}(t) = \mathbf{A}\underline{x}(t) + \mathbf{B}\underline{u}(t) \\ \underline{x}(0) = \underline{x}_0 \end{cases} \quad (2.110)$$

Where:

- \mathbf{A} is the state (or system) matrix
- \mathbf{B} is the input matrix
- $\underline{x}(t)$ is the state vector of dimension n
- $\underline{u}(t)$ is the control vector of dimension m

We will assume that the pair (\mathbf{A}, \mathbf{B}) is controllable. The purpose of this section is to explicit the control $\underline{u}(t)$ which minimizes the following quadratic performance index with cross-terms:

$$J(\underline{u}(t)) = \frac{1}{2} \int_0^{t_f} \underline{x}^T(t) \mathbf{Q} \underline{x}(t) + \underline{u}^T(t) \mathbf{R} \underline{u}(t) + 2 \underline{x}^T(t) \mathbf{S} \underline{u}(t) dt \quad (2.111)$$

With the constraint on terminal state:

$$\underline{x}(t_f) = \underline{0} \quad (2.112)$$

Matrices \mathbf{S} and \mathbf{Q} are symmetric positive semi-definite and matrix \mathbf{R} symmetric positive definite:

$$\begin{cases} \mathbf{S} = \mathbf{S}^T \geq 0 \\ \mathbf{Q} = \mathbf{Q}^T \geq 0 \\ \mathbf{R} = \mathbf{R}^T > 0 \end{cases} \quad (2.113)$$

It can be seen that:

$$\underline{x}^T(t) \mathbf{Q} \underline{x}(t) + \underline{u}^T(t) \mathbf{R} \underline{u}(t) + 2 \underline{x}^T(t) \mathbf{S} \underline{u}(t) = \underline{x}^T(t) \mathbf{Q}_m \underline{x}(t) + \underline{v}^T(t) \mathbf{R} \underline{v}(t) \quad (2.114)$$

Where:

$$\begin{cases} \mathbf{Q}_m = \mathbf{Q} - \mathbf{S} \mathbf{R}^{-1} \mathbf{S}^T \\ \underline{v}(t) = \underline{u}(t) + \mathbf{R}^{-1} \mathbf{S}^T \underline{x}(t) \end{cases} \quad (2.115)$$

Hence cost (2.111) to be minimized can be rewritten as:

$$J(\underline{u}(t)) = \frac{1}{2} \int_0^\infty \underline{x}^T(t) \mathbf{Q}_m \underline{x}(t) + \underline{v}^T(t) \mathbf{R} \underline{v}(t) dt \quad (2.116)$$

Furthermore (2.110) is rewritten as follows, where $\underline{v}(t)$ appears as the control vector rather than $\underline{u}(t)$. Using $\underline{u}(t) = \underline{v}(t) - \mathbf{R}^{-1} \mathbf{S}^T \underline{x}(t)$ in (2.110) leads to the following state equation:

$$\begin{aligned} \dot{\underline{x}}(t) &= \mathbf{A} \underline{x}(t) + \mathbf{B} (\underline{v}(t) - \mathbf{R}^{-1} \mathbf{S}^T \underline{x}(t)) \\ &= (\mathbf{A} - \mathbf{B} \mathbf{R}^{-1} \mathbf{S}^T) \underline{x}(t) + \mathbf{B} \underline{v}(t) \\ &= \mathbf{A}_m \underline{x}(t) + \mathbf{B} \underline{v}(t) \end{aligned} \quad (2.117)$$

We will assume that symmetric matrix \mathbf{Q}_m is positive semi-definite:

$$\mathbf{Q}_m = \mathbf{Q} - \mathbf{S} \mathbf{R}^{-1} \mathbf{S}^T \geq 0 \quad (2.118)$$

Hamiltonian matrix \mathbf{H} reads:

$$\mathbf{H} = \begin{bmatrix} \mathbf{A}_m & -\mathbf{B} \mathbf{R}^{-1} \mathbf{B}^T \\ -\mathbf{Q}_m & -\mathbf{A}_m^T \end{bmatrix} = \begin{bmatrix} \mathbf{A} - \mathbf{B} \mathbf{R}^{-1} \mathbf{S}^T & -\mathbf{B} \mathbf{R}^{-1} \mathbf{B}^T \\ -\mathbf{Q} + \mathbf{S} \mathbf{R}^{-1} \mathbf{S}^T & -\mathbf{A}^T + \mathbf{S} \mathbf{R}^{-1} \mathbf{B}^T \end{bmatrix} \quad (2.119)$$

The problem can be solved through the following Hamiltonian system whose state is obtained by extending the state $\underline{x}(t)$ of system (2.110) with costate $\underline{\lambda}(t)$:

$$\begin{bmatrix} \dot{\underline{x}}(t) \\ \dot{\underline{\lambda}}(t) \end{bmatrix} = \begin{bmatrix} \mathbf{A} - \mathbf{B} \mathbf{R}^{-1} \mathbf{S}^T & -\mathbf{B} \mathbf{R}^{-1} \mathbf{B}^T \\ -\mathbf{Q} + \mathbf{S} \mathbf{R}^{-1} \mathbf{S}^T & -\mathbf{A}^T + \mathbf{S} \mathbf{R}^{-1} \mathbf{B}^T \end{bmatrix} \begin{bmatrix} \underline{x}(t) \\ \underline{\lambda}(t) \end{bmatrix} := \mathbf{H} \begin{bmatrix} \underline{x}(t) \\ \underline{\lambda}(t) \end{bmatrix} \quad (2.120)$$

Ntogramatzidis² has shown the following results: let \mathbf{P}_1 and \mathbf{P}_2 be the *positive semi-definite solutions* of the following continuous time algebraic Riccati equations:

$$\begin{cases} \mathbf{0} = \mathbf{A}^T \mathbf{P}_1 + \mathbf{P}_1 \mathbf{A} - (\mathbf{S} + \mathbf{P}_1 \mathbf{B}) \mathbf{R}^{-1} (\mathbf{S} + \mathbf{P}_1 \mathbf{B})^T + \mathbf{Q} \\ \mathbf{0} = -\mathbf{A}^T \mathbf{P}_2 - \mathbf{P}_2 \mathbf{A} - (\mathbf{S} - \mathbf{P}_2 \mathbf{B}) \mathbf{R}^{-1} (\mathbf{S} - \mathbf{P}_2 \mathbf{B})^T + \mathbf{Q} \end{cases} \quad (2.121)$$

Notice that pair (\mathbf{A}, \mathbf{B}) has been replaced by $(-\mathbf{A}, -\mathbf{B})$ in the second equation. We will denote by \mathbf{K}_1 and \mathbf{K}_2 the following *infinite* horizon gain matrices:

$$\begin{cases} \mathbf{K}_1 = \mathbf{R}^{-1} (\mathbf{S}^T + \mathbf{B}^T \mathbf{P}_1) \\ \mathbf{K}_2 = \mathbf{R}^{-1} (\mathbf{S}^T - \mathbf{B}^T \mathbf{P}_2) \end{cases} \quad (2.122)$$

Then the optimal control reads:

$$\underline{u}(t) = \begin{cases} -\mathbf{K}(t)\underline{x}(t) & \forall 0 \leq t < t_f \\ 0 & \text{for } t = t_f \end{cases} \quad (2.123)$$

Where:

$$\begin{cases} \mathbf{K}(t) = \mathbf{R}^{-1} (\mathbf{S}^T + \mathbf{B}^T \mathbf{P}(t)) \\ \mathbf{P}(t) = \mathbf{X}_2(t) \mathbf{X}_1^{-1}(t) \end{cases} \quad (2.124)$$

And:

$$\begin{cases} \mathbf{X}_1(t) = e^{(\mathbf{A}-\mathbf{BK}_1)t} - e^{(\mathbf{A}-\mathbf{BK}_2)(t-t_f)} e^{(\mathbf{A}-\mathbf{BK}_1)t_f} \\ \mathbf{X}_2(t) = \mathbf{P}_1 e^{(\mathbf{A}-\mathbf{BK}_1)t} + \mathbf{P}_2 e^{(\mathbf{A}-\mathbf{BK}_2)(t-t_f)} e^{(\mathbf{A}-\mathbf{BK}_1)t_f} \end{cases} \quad (2.125)$$

Matrix $\mathbf{P}(t)$ satisfy the following Riccati differential equation:

$$-\dot{\mathbf{P}}(t) = \mathbf{A}^T \mathbf{P} + \mathbf{P} \mathbf{A} - (\mathbf{S} + \mathbf{B} \mathbf{P}(t)) \mathbf{R}^{-1} (\mathbf{S} + \mathbf{B} \mathbf{P}(t))^T + \mathbf{Q} \quad (2.126)$$

Furthermore the optimal state $\underline{x}(t)$ and costate $\underline{\lambda}(t)$ have the following expressions:

$$\begin{cases} \underline{x}(t) = \mathbf{X}_1(t) \mathbf{X}_1^{-1}(0) \underline{x}_0 \\ \underline{\lambda}(t) = \mathbf{X}_2(t) \mathbf{X}_1^{-1}(0) \underline{x}_0 \end{cases} \quad (2.127)$$

2.11 Extension to nonlinear system affine in control

We consider the following finite horizon optimal control problem consisting in finding the control \underline{u} that minimizes the following performance index where $q(\underline{x})$ is positive semi-definite and $\mathbf{R} = \mathbf{R}^T > 0$:

$$J(\underline{u}(t)) = G(\underline{x}(t_f)) + \frac{1}{2} \int_0^{t_f} (q(\underline{x}) + \underline{u}^T(t) \mathbf{R} \underline{u}(t)) dt \quad (2.128)$$

under the *constraint* that the system is nonlinear but affine in control:

$$\begin{cases} \dot{\underline{x}}(t) = \underline{f}(\underline{x}) + \underline{g}(\underline{x}) \underline{u}(t) \\ \underline{x}(0) = \underline{x}_0 \end{cases} \quad (2.129)$$

²Lorenzo Ntogramatzidis, A simple solution to the finite-horizon LQ problem with zero terminal state, Kybernetika - 39(4):483-492, January 2003

Assuming no constraint, control $\underline{u}^*(t)$ that *minimizes* the performance index $J(\underline{u}(t))$ is defined by:

$$\underline{u}^*(t) = -\mathbf{R}^{-1}\underline{g}^T(\underline{x})\underline{\lambda}(t) \quad (2.130)$$

where:

$$\begin{aligned} \dot{\underline{\lambda}}(t) &= -\left(\frac{1}{2}\left(\frac{\partial q(\underline{x})}{\partial \underline{x}}\right)^T + \frac{\partial(f(\underline{x})+g(\underline{x})\underline{u}^*)}{\partial \underline{x}}\underline{\lambda}(t)\right) \\ &= -\left(\frac{1}{2}\left(\frac{\partial q(\underline{x})}{\partial \underline{x}}\right)^T + \frac{\partial(f(\underline{x})-g(\underline{x})\mathbf{R}^{-1}\underline{g}^T(\underline{x})\underline{\lambda}(t))}{\partial \underline{x}}\underline{\lambda}(t)\right) \end{aligned} \quad (2.131)$$

For boundary value problems, efficient minimization of the Hamiltonian is possible³.

³Todorov E. and Tassa Y., Iterative Local Dynamic Programming, IEEE ADPRL, 2009

Chapter 3

Infinite Horizon Linear Quadratic Regulator (LQR)

3.1 Problem to be solved

We recall that we consider the following linear time invariant system, where $\underline{x}(t)$ is the state vector of dimension n , $\underline{u}(t)$ is the control vector of dimension m and $\underline{z}(t)$ is the *controlled* output (that is not the *actual* output of the system but the output of *interest* for the design):

$$\begin{cases} \dot{\underline{x}}(t) = \mathbf{A}\underline{x}(t) + \mathbf{B}\underline{u}(t) \\ \underline{z}(t) = \mathbf{N}\underline{x}(t) \\ \underline{x}(0) = \underline{x}_0 \end{cases} \quad (3.1)$$

We recall hereafter the performance index which was under consideration in the previous chapter dealing with finite horizon Linear Quadratic Regulator (LQR) when the final state \underline{x}_f is set:

$$J(\underline{u}(t)) = \frac{1}{2} \int_0^{t_f} \underline{x}^T(t) \mathbf{Q} \underline{x}(t) + \underline{u}^T(t) \mathbf{R} \underline{u}(t) dt \quad (3.2)$$

where $\mathbf{Q} = \mathbf{N}^T \mathbf{N} \geq 0$ (thus \mathbf{Q} is symmetric and positive semi-definite) and $\mathbf{R} = \mathbf{R}^T > 0$ is a symmetric and positive definite matrix.

In this chapter we will focus on the case where the final time t_f tends toward infinity ($t_f \rightarrow \infty$). The performance index to be minimized turns to be:

$$J(\underline{u}(t)) = \frac{1}{2} \int_0^{\infty} (\underline{x}^T(t) \mathbf{Q} \underline{x}(t) + \underline{u}^T(t) \mathbf{R} \underline{u}(t)) dt \quad (3.3)$$

The results presented in this chapter can be envisioned as the results of the previous chapter as $\|\mathbf{S}\| \rightarrow \infty$ ($\underline{x}_f := \underline{0}$ here) and $t_f \rightarrow \infty$. When the final time t_f is set to infinity, the Kalman gain $\mathbf{K}(t)$ which has been computed in the previous chapter becomes constant. As a consequence, the control is easier to implement as far as it is no more necessary to integrate the differential Riccati equation and to store the gain $\mathbf{K}(t)$ before applying the control. In practice *infinity* means that final time t_f becomes large when compared to the time constants of the plant.

3.2 Stabilizability and detectability

We will assume in the following that (\mathbf{A}, \mathbf{B}) is stabilizable and (\mathbf{A}, \mathbf{N}) is detectable. We recall that the pair (\mathbf{A}, \mathbf{B}) is said stabilizable if the uncontrollable eigenvalues of \mathbf{A} , if any, have negative real parts. Thus even though not all system modes are controllable, the ones that are not controllable do not require stabilization.

Similarly the pair (\mathbf{A}, \mathbf{N}) is said detectable if the unobservable eigenvalues of \mathbf{A} , if any, have negative real parts. Thus even though not all system modes are observable, the ones that are not observable do not require stabilization. We may use the Kalman test to check the controllability of the system:

$$\text{rank} [\mathbf{B} \quad \mathbf{AB} \quad \cdots \quad \mathbf{A}^{n-1}\mathbf{B}] = n \quad \text{where } n = \text{size of state vector } \underline{x} \quad (3.4)$$

Or equivalently the Popov-Belevitch-Hautus (*PBH*) test which shall be applied to all eigenvalues of \mathbf{A} , denoted λ_i , to check the controllability of the system, or only on the eigenvalues which are not contained in the left half plane to check the stabilizability of the system:

$$\text{rank} [\mathbf{A} - \lambda_i \mathbb{I} \quad \mathbf{B}] = n \quad \begin{cases} \forall \lambda_i \text{ for controllability} \\ \forall \lambda_i \text{ s.t. } \text{Re}(\lambda_i) \geq 0 \text{ for stabilizability} \end{cases} \quad (3.5)$$

Similarly we may use the Kalman test to check the observability of the system:

$$\text{rank} \begin{bmatrix} \mathbf{N} \\ \mathbf{NA} \\ \vdots \\ \mathbf{NA}^{n-1} \end{bmatrix} = n \quad \text{where } n = \text{size of state vector } \underline{x} \quad (3.6)$$

Or equivalently the Popov-Belevitch-Hautus (*PBH*) test which shall be applied to all eigenvalues of \mathbf{A} , denoted λ_i , to check the observability of the system, or only on the eigenvalues which are not contained in the left half plane to check the detectability of the system:

$$\text{rank} \begin{bmatrix} \mathbf{A} - \lambda_i \mathbb{I} \\ \mathbf{N} \end{bmatrix} = n \quad \begin{cases} \forall \lambda_i \text{ for observability} \\ \forall \lambda_i \text{ s.t. } \text{Re}(\lambda_i) \geq 0 \text{ for detectability} \end{cases} \quad (3.7)$$

3.3 Algebraic Riccati equation

When final time t_f tends toward infinity the matrix $\mathbf{P}(t)$ turns to be a constant symmetric positive definite matrix denoted \mathbf{P} . The *Riccati* equation (2.44) reduces to an algebraic equation, which is known as the *algebraic Riccati equation* (ARE):

$$\mathbf{A}^T \mathbf{P} + \mathbf{P} \mathbf{A} - \mathbf{P} \mathbf{B} \mathbf{R}^{-1} \mathbf{B}^T \mathbf{P} + \mathbf{Q} = \mathbf{0} \quad (3.8)$$

It is worth noticing that the *algebraic Riccati* equation (3.8) may have several solutions. The solution of the optimal control problem only retains the *positive semi-definite solution of the algebraic Riccati* equation.

The convergence of $\lim_{t_f \rightarrow \infty} \mathbf{P}(t) \rightarrow \mathbf{P}$ where $\mathbf{P} \geq 0$ is some positive semi-definite symmetric constant matrix is guaranteed by the stabilizability assumption (\mathbf{P}^T is indeed a solution of the algebraic Riccati equation (3.8)). Since the matrix $\mathbf{P} = \mathbf{P}^T \geq 0$ is constant, the optimal gain $\mathbf{K}(t)$ also turns to be also a constant denoted \mathbf{K} . The optimal gain \mathbf{K} and the optimal stabilizing control $\underline{u}(t)$ are then defined as follows:

$$\begin{cases} \underline{u}(t) = -\mathbf{K}\underline{x}(t) \\ \mathbf{K} = \mathbf{R}^{-1}\mathbf{B}^T\mathbf{P} \end{cases} \quad (3.9)$$

The need for the detectability assumption is to ensure that the optimal control computed using the $\lim_{t_f \rightarrow \infty} \mathbf{P}(t)$ generates a feedback gain $\mathbf{K} = \mathbf{R}^{-1}\mathbf{B}^T\mathbf{P}$ that stabilizes the plant, i.e. all the eigenvalues of $\mathbf{A} - \mathbf{BK}$ lie on the open left half plane. In addition, it can be shown that the minimum cost achieved is given by:

$$J^* = \frac{1}{2}\underline{x}^T(0)\mathbf{P}\underline{x}(0) \quad (3.10)$$

To get this result first we notice that the Hamiltonian (1.63) reads:

$$\mathcal{H}(\underline{x}, \underline{u}, \underline{\lambda}) = \frac{1}{2}(\underline{x}^T(t)\mathbf{Q}\underline{x}(t) + \underline{u}^T(t)\mathbf{R}\underline{u}(t)) + \underline{\lambda}^T(t)(\mathbf{A}\underline{x}(t) + \mathbf{B}\underline{u}(t)) \quad (3.11)$$

The necessary condition for optimality (1.72) yields:

$$\frac{\partial \mathcal{H}}{\partial \underline{u}} = \mathbf{R}\underline{u}(t) + \mathbf{B}^T\underline{\lambda}(t) = 0 \quad (3.12)$$

Taking into account that \mathbf{R} is a symmetric matrix, we get:

$$\underline{u}(t) = -\mathbf{R}^{-1}\mathbf{B}^T\underline{\lambda}(t) \quad (3.13)$$

Eliminating $\underline{u}(t)$ in equation (3.1) reads:

$$\dot{\underline{x}}(t) = \mathbf{A}\underline{x}(t) - \mathbf{B}\mathbf{R}^{-1}\mathbf{B}^T\underline{\lambda}(t) \quad (3.14)$$

The dynamics of Lagrange multipliers $\underline{\lambda}(t)$ is given by (1.69):

$$\dot{\underline{\lambda}}(t) = -\frac{\partial \mathcal{H}}{\partial \underline{x}} = -\mathbf{Q}\underline{x}(t) - \mathbf{A}^T\underline{\lambda}(t) \quad (3.15)$$

The key point in the LQR design is that Lagrange multipliers $\underline{\lambda}(t)$ are now assume to linearly depends on state vector $\underline{x}(t)$ through a constant symmetric positive definite matrix denoted \mathbf{P} :

$$\underline{\lambda}(t) = \mathbf{P}\underline{x}(t) \text{ where } \mathbf{P} = \mathbf{P}^T \geq 0 \quad (3.16)$$

By taking the time derivative of the Lagrange multipliers $\underline{\lambda}(t)$ and using again equation (3.1) we get:

$$\dot{\underline{\lambda}}(t) = \mathbf{P}\dot{\underline{x}}(t) = \mathbf{P}(\mathbf{A}\underline{x}(t) + \mathbf{B}\underline{u}(t)) = \mathbf{P}\mathbf{A}\underline{x}(t) + \mathbf{P}\mathbf{B}\underline{u}(t) \quad (3.17)$$

Then using the expression of control $\underline{u}(t)$ provided in (3.13) as well as (3.16) we get:

$$\begin{aligned}\dot{\underline{\lambda}}(t) &= \mathbf{P}\mathbf{A}\underline{x}(t) - \mathbf{P}\mathbf{B}\mathbf{R}^{-1}\mathbf{B}^T\underline{\lambda}(t) \\ &= \mathbf{P}\mathbf{A}\underline{x}(t) - \mathbf{P}\mathbf{B}\mathbf{R}^{-1}\mathbf{B}^T\mathbf{P}\underline{x}(t)\end{aligned}\quad (3.18)$$

Finally using (3.18) within (3.15) and using $\underline{\lambda}(t) = \mathbf{P}\underline{x}(t)$ (see (3.16)) we get:

$$\begin{aligned}-\mathbf{P}\mathbf{A}\underline{x}(t) + \mathbf{P}\mathbf{B}\mathbf{R}^{-1}\mathbf{B}^T\mathbf{P}\underline{x}(t) &= \mathbf{Q}\underline{x}(t) + \mathbf{A}^T\mathbf{P}\underline{x}(t) \\ \Leftrightarrow (\mathbf{A}^T\mathbf{P} + \mathbf{P}\mathbf{A} - \mathbf{P}\mathbf{B}\mathbf{R}^{-1}\mathbf{B}^T\mathbf{P} + \mathbf{Q})\underline{x}(t) &= \underline{\mathbf{0}}\end{aligned}\quad (3.19)$$

As far as this equality stands for every value of the state vector $\underline{x}(t)$ we retrieve the algebraic Riccati equation (3.8):

$$\mathbf{A}^T\mathbf{P} + \mathbf{P}\mathbf{A} - \mathbf{P}\mathbf{B}\mathbf{R}^{-1}\mathbf{B}^T\mathbf{P} + \mathbf{Q} = \mathbf{0}\quad (3.20)$$

3.4 Extension to nonlinear system affine in control

We consider the following infinite horizon optimal control problem consisting in finding the control \underline{u} that minimizes the following performance index where $q(\underline{x})$ is positive semi-definite:

$$J(\underline{u}(t)) = \frac{1}{2} \int_0^\infty (q(\underline{x}) + \underline{u}^T(t)\underline{u}(t)) dt \quad (3.21)$$

under the *constraint* that the system is nonlinear but affine in control:

$$\begin{cases} \dot{\underline{x}} = \underline{f}(\underline{x}) + \underline{g}(\underline{x})\underline{u}(t) \\ \underline{x}(0) = \underline{x}_0 \end{cases} \quad (3.22)$$

We assume that vector field \underline{f} is such that $\underline{f}(\underline{x}) = \underline{\mathbf{0}}$. Thus $(\underline{x}_e := \underline{\mathbf{0}}, \underline{u}_e := \underline{\mathbf{0}})$ is an equilibrium point for the nonlinear system affine in control. Consequently $\underline{f}(\underline{x}) = \mathbf{F}(\underline{x})\underline{x}$ for some, possibly not unique, continuous function $\mathbf{F} : \mathbb{R}^n \rightarrow \mathbb{R}^{n \times n}$. The classical optimal control design methodology relies on the solution of the Hamilton-Jacobi-Bellman (HJB) equation (1.112):

$$0 = \min_{\underline{u}(t) \in \mathcal{U}} \left(\frac{1}{2} (q(\underline{x}) + \underline{u}^T \underline{u}) + \left(\frac{\partial J^*(\underline{x})}{\partial \underline{x}} \right)^T (\underline{f}(\underline{x}) + \underline{g}(\underline{x}) \underline{u}) \right) \quad (3.23)$$

Assuming no constraint, the minimum of the preceding Hamilton-Jacobi-Bellman (HJB) equation with respect to \underline{u} is attained for optimal control $\underline{u}^*(t)$ defined by:

$$\underline{u}^*(t) = -\underline{g}^T(\underline{x}) \left(\frac{\partial J^*(\underline{x})}{\partial \underline{x}} \right) \quad (3.24)$$

Then replacing \underline{u} by $\underline{u}^* = -\underline{g}^T(\underline{x}) \left(\frac{\partial J^*(\underline{x})}{\partial \underline{x}} \right)$, the Hamilton-Jacobi-Bellman (HJB) equation reads:

$$\begin{aligned}0 &= \frac{1}{2} \left(q(\underline{x}) + \left(\frac{\partial J^*(\underline{x})}{\partial \underline{x}} \right)^T \underline{g}(\underline{x}) \underline{g}^T(\underline{x}) \left(\frac{\partial J^*(\underline{x})}{\partial \underline{x}} \right) \right) \\ &\quad + \left(\frac{\partial J^*(\underline{x})}{\partial \underline{x}} \right)^T \left(\underline{f}(\underline{x}) - \underline{g}(\underline{x}) \underline{g}^T(\underline{x}) \left(\frac{\partial J^*(\underline{x})}{\partial \underline{x}} \right) \right)\end{aligned}\quad (3.25)$$

We finally get:

$$\frac{1}{2}q(\underline{x}) + \left(\frac{\partial J^*(\underline{x})}{\partial \underline{x}} \right)^T \underline{f}(\underline{x}) - \frac{1}{2} \left(\frac{\partial J^*(\underline{x})}{\partial \underline{x}} \right)^T \underline{g}(\underline{x}) \underline{g}^T(\underline{x}) \left(\frac{\partial J^*(\underline{x})}{\partial \underline{x}} \right) = 0 \quad (3.26)$$

In the linearized case the solution of the optimal control problem is a linear static state feedback of the form $\underline{u} = -\mathbf{B}^T \bar{\mathbf{P}}$, where $\bar{\mathbf{P}}$ is the symmetric positive definite solution of the algebraic Riccati equation:

$$\mathbf{A}^T \bar{\mathbf{P}} + \bar{\mathbf{P}} \mathbf{A} - \bar{\mathbf{P}} \mathbf{B} \mathbf{B}^T \bar{\mathbf{P}} + \mathbf{Q} = \mathbf{0} \quad (3.27)$$

where:

$$\begin{cases} \mathbf{A} = \left. \frac{\partial \underline{f}(\underline{x})}{\partial \underline{x}} \right|_{\underline{x}=\underline{0}} \\ \mathbf{B} = \underline{g}(\underline{0}) \\ \mathbf{Q} = \left. \frac{1}{2} \frac{\partial^2 q(\underline{x})}{\partial \underline{x}^2} \right|_{\underline{x}=\underline{0}} \end{cases} \quad (3.28)$$

Following Sassano and Astolfi¹, there exists a matrix $\mathbf{R} = \mathbf{R}^T > 0$, a neighbourhood of the origin $\Omega \subseteq \mathbb{R}^{2n}$ and $\bar{k} \geq 0$ such that for all $k \geq \bar{k}$ the function $V(\underline{x}, \underline{\xi})$ is positive definite and satisfies the following partial differential inequality:

$$\frac{1}{2}q(\underline{x}) + V_{\underline{x}}(\underline{x}, \underline{\xi}) \underline{f}(\underline{x}) + V_{\underline{\xi}}(\underline{x}, \underline{\xi}) \dot{\underline{\xi}} - \frac{1}{2} V_{\underline{x}}(\underline{x}, \underline{\xi}) \underline{g}(\underline{x}) \underline{g}^T(\underline{x}) V_{\underline{x}}^T(\underline{x}, \underline{\xi}) \leq 0 \quad (3.29)$$

where:

$$\begin{cases} V(\underline{x}, \underline{\xi}) = P(\underline{\xi}) \underline{x} + \frac{1}{2} (\underline{x} - \underline{\xi})^T \mathbf{R} (\underline{x} - \underline{\xi}) \\ \dot{\underline{\xi}} = -k V_{\underline{\xi}}^T(\underline{x}, \underline{\xi}) \quad \forall (\underline{x}, \underline{\xi}) \in \Omega \end{cases} \quad (3.30)$$

The \mathcal{C}^1 mapping $P : \mathbb{R}^n \rightarrow \mathbb{R}^{1 \times n}$, $P(\underline{0}) = \underline{0}^T$, is defined as follows:

$$\frac{1}{2}q(\underline{x}) + P(\underline{x}) \underline{f}(\underline{x}) - \frac{1}{2} P(\underline{x}) \underline{g}(\underline{x}) \underline{g}^T(\underline{x}) P(\underline{x})^T + \sigma(\underline{x}) = 0 \quad (3.31)$$

where $\sigma(\underline{x}) = \underline{x}^T \Sigma(\underline{x}) \underline{x}$ with $\Sigma : \mathbb{R}^n \rightarrow \mathbb{R}^{n \times n}$, $\Sigma(\underline{0}) = \underline{0}$.

Furthermore $P(\underline{x})$ is tangent at $\underline{x} = \underline{0}$ to $\bar{\mathbf{P}}$:

$$\left. \frac{\partial P(\underline{x})^T}{\partial \underline{x}} \right|_{\underline{x}=\underline{0}} = \bar{\mathbf{P}} \quad (3.32)$$

Since $P(\underline{x})$ is tangent at $\underline{x} = \underline{0}$ to the solution $\bar{\mathbf{P}}$ of the algebraic Riccati equation, the function $P(\underline{x}) \underline{x} : \mathbb{R}^n \rightarrow \mathbb{R}$ is locally quadratic around the origin and moreover has a local minimum for $\underline{x} = \underline{0}$.

Let $\Psi(\underline{\xi})$ be Jacobian matrix of the mapping $P(\underline{\xi})$ and $\Phi : \mathbb{R}^n \times \mathbb{R}^n \rightarrow \mathbb{R}^{n \times n}$ a continuous matrix valued function such that:

$$\begin{cases} P(\underline{\xi}) = \underline{\xi}^T \Psi(\underline{\xi})^T \\ P(\underline{x}) - P(\underline{\xi}) = (\underline{x} - \underline{\xi})^T \Phi(\underline{x}, \underline{\xi})^T \end{cases} \quad (3.33)$$

¹Sassano M. and Astolfi A, Dynamic approximate solutions of the HJ inequality and of the HJB equation for input-affine nonlinear systems. IEEE Transactions on Automatic Control, 57(10):2490–2503, 2012.

Then the approximate regional dynamic optimal control is found to be¹:

$$\begin{aligned}
\underline{u} &= -\underline{g}(\underline{x})^T V_x^T(\underline{x}, \underline{\xi}) \\
&= -\underline{g}(\underline{x})^T (P(\underline{\xi})^T + \mathbf{R}(\underline{x} - \underline{\xi})) \\
&= -\underline{g}(\underline{x})^T (P(\underline{x})^T + \mathbf{R}(\underline{x} - \underline{\xi}) - (P(\underline{x})^T - P(\underline{\xi})^T)) \\
&= -\underline{g}(\underline{x})^T (P(\underline{x})^T + (\mathbf{R} - \Phi(\underline{x}, \underline{\xi}))(\underline{x} - \underline{\xi}))
\end{aligned} \tag{3.34}$$

where:

$$\dot{\underline{\xi}} = -k V_{\underline{\xi}}^T(\underline{x}, \underline{\xi}) = -k (\Psi(\underline{\xi})^T \underline{x} - \mathbf{R}(\underline{x} - \underline{\xi})) \tag{3.35}$$

Such control has been applied to internal combustion engine test benches².

3.5 Solving the algebraic Riccati equation

3.5.1 Hamiltonian matrix based solution

It can be shown that if the pair (\mathbf{A}, \mathbf{B}) is stabilizable and the pair (\mathbf{A}, \mathbf{N}) is detectable, with $\mathbf{Q} = \mathbf{N}^T \mathbf{N}$ positive semi-definite and \mathbf{R} positive definite, then \mathbf{P} is the unique positive semi-definite (symmetric) solution of the *algebraic Riccati equation* (ARE) (3.8).

Combining (3.14) and (3.15) into a single state equation yields:

$$\begin{bmatrix} \dot{\underline{x}}(t) \\ \dot{\underline{\lambda}}(t) \end{bmatrix} = \begin{bmatrix} \mathbf{A} & -\mathbf{B}\mathbf{R}^{-1}\mathbf{B}^T \\ -\mathbf{Q} & -\mathbf{A}^T \end{bmatrix} \begin{bmatrix} \underline{x}(t) \\ \underline{\lambda}(t) \end{bmatrix} := \mathbf{H} \begin{bmatrix} \underline{x}(t) \\ \underline{\lambda}(t) \end{bmatrix} \tag{3.36}$$

We have seen that the following $2n \times 2n$ matrix \mathbf{H} is called the Hamiltonian matrix:

$$\mathbf{H} = \begin{bmatrix} \mathbf{A} & -\mathbf{B}\mathbf{R}^{-1}\mathbf{B}^T \\ -\mathbf{Q} & -\mathbf{A}^T \end{bmatrix} \tag{3.37}$$

It can be shown that the Hamiltonian matrix \mathbf{H} has n eigenvalues in the open left half plane and n eigenvalues in the open right half plane. The eigenvalues are symmetric with respects to the imaginary axis: if $\underline{\lambda}$ is and eigenvalue of \mathbf{H} then $-\underline{\lambda}$ is also an eigenvalue of \mathbf{H} . In addition \mathbf{H} has no pure imaginary eigenvalues.

Furthermore if the $2n \times n$ matrix $\begin{bmatrix} \mathbf{X}_1 \\ \mathbf{X}_2 \end{bmatrix}$ has columns that comprise all the eigenvectors of \mathbf{H} corresponding to the n eigenvalues in the *open left half plane*. Then \mathbf{X}_1 is invertible and the positive semi-definite solution of the *algebraic Riccati equation* (ARE) is:

$$\mathbf{P} = \mathbf{X}_2 \mathbf{X}_1^{-1} \tag{3.38}$$

Similarly the negative semi-definite solution of the *algebraic Riccati equation* (ARE) is build thanks to the eigenvectors associated with the n eigenvalues in the open right half plane (i.e. the unstable invariant subspace). Once again the solution of the optimal control problem only retains the positive semi-definite solution of the *algebraic Riccati* equation.

²Passenbrunner T., Sassano M., del Re L., Optimal Control with Input Constraints applied to Internal Combustion Engine Test Benches, 9th IFAC Symposium on Nonlinear Control Systems, September 4-6, 2013. Toulouse, France

In addition it can be shown that the eigenvalues of $\mathbf{A} - \mathbf{BK}$ where $\mathbf{K} = \mathbf{R}^{-1}\mathbf{B}^T\mathbf{P}$ (that are the eigenvalues of the closed-loop plant) are equal to the n eigenvalues in the open left half plane of the Hamiltonian matrix \mathbf{H} .

3.5.2 Proof of the results on the Hamiltonian matrix

We recall that, by definition, a matrix \mathbf{H} is said to be an Hamiltonian matrix as soon as the following property holds:

$$(\mathbf{JH})^T = \mathbf{JH} \Leftrightarrow (\mathbf{HJ})^T = \mathbf{HJ} \text{ where } \mathbf{J} = \begin{bmatrix} \mathbf{0} & \mathbb{I} \\ -\mathbb{I} & \mathbf{0} \end{bmatrix} \quad (3.39)$$

Matrix \mathbf{J} as the following properties:

$$\mathbf{J}^T\mathbf{J} = \mathbf{J}\mathbf{J}^T = \begin{bmatrix} \mathbb{I} & \mathbf{0} \\ \mathbf{0} & \mathbb{I} \end{bmatrix} \text{ and } \mathbf{J}\mathbf{J} = \mathbf{J}^T\mathbf{J}^T = -\begin{bmatrix} \mathbb{I} & \mathbf{0} \\ \mathbf{0} & \mathbb{I} \end{bmatrix} \quad (3.40)$$

In addition the following relation holds:

$$\mathbf{HJ} = (\mathbf{HJ})^T \Rightarrow \mathbf{J}^T\mathbf{HJ} = \mathbf{J}^T\mathbf{J}^T\mathbf{H}^T = -\mathbf{H}^T \quad (3.41)$$

Let λ be an eigenvalue of Hamiltonian matrix \mathbf{H} associated with eigenvector \underline{x} . We get:

$$\begin{aligned} \mathbf{H}\underline{x} &= \lambda \underline{x} \\ \Rightarrow \mathbf{HJ}\mathbf{J}^T\underline{x} &= \lambda \underline{x} \\ \Rightarrow \mathbf{J}^T\mathbf{HJ}\mathbf{J}^T\underline{x} &= \lambda \mathbf{J}^T\underline{x} \\ \Leftrightarrow -\mathbf{H}^T\mathbf{J}^T\underline{x} &= \lambda \mathbf{J}^T\underline{x} \\ \Leftrightarrow \mathbf{H}^T\mathbf{J}^T\underline{x} &= -\lambda \mathbf{J}^T\underline{x} \end{aligned} \quad (3.42)$$

Thus $-\lambda$ is an eigenvalue of \mathbf{H}^T with the corresponding eigenvector $\mathbf{J}^T\underline{x}$. Using the fact that $\det(\mathbf{M}) = \det(\mathbf{M}^T)$ we get:

$$\det(-\lambda\mathbb{I} - \mathbf{H}^T) = \det((-\lambda\mathbb{I} - \mathbf{H})^T) \quad (3.43)$$

As a consequence we conclude that $-\lambda$ is also an eigenvalue of \mathbf{H} .

To show that \mathbf{H} has no eigenvalue on the imaginary axis suppose:

$$\mathbf{H} \begin{bmatrix} \underline{x}_1 \\ \underline{x}_2 \end{bmatrix} = \begin{bmatrix} \mathbf{A} & -\mathbf{BR}^{-1}\mathbf{B}^T \\ -\mathbf{Q} & -\mathbf{A}^T \end{bmatrix} \begin{bmatrix} \underline{x}_1 \\ \underline{x}_2 \end{bmatrix} = \lambda \begin{bmatrix} \underline{x}_1 \\ \underline{x}_2 \end{bmatrix} \quad (3.44)$$

Where \underline{x}_1 and \underline{x}_2 are *not* both zero and

$$\lambda + \lambda^* = 0 \quad (3.45)$$

where λ^* stands for the complex conjugate of λ . We seek a contradiction. Let's denote by \underline{x}^* the transpose conjugate of vector \underline{x} .

– Equation (3.44) gives:

$$\mathbf{A}\underline{x}_1 - \mathbf{BR}^{-1}\mathbf{B}^T\underline{x}_2 = \lambda\underline{x}_1 \Rightarrow \underline{x}_2^*\mathbf{BR}^{-1}\mathbf{B}^T\underline{x}_2 = \underline{x}_2^*\mathbf{A}\underline{x}_1 - \lambda\underline{x}_2^*\underline{x}_1 \quad (3.46)$$

- Taking into account that \mathbf{Q} is a real symmetric matrix, equation (3.44) also gives:

$$-\mathbf{Q}\underline{x}_1 - \mathbf{A}^T \underline{x}_2 = \lambda \underline{x}_2 \Rightarrow \lambda \underline{x}_2^T = -\underline{x}_1^T \mathbf{Q} - \underline{x}_2^T \mathbf{A} \Rightarrow \lambda^* \underline{x}_2^* = -\underline{x}_1^* \mathbf{Q} - \underline{x}_2^* \mathbf{A} \quad (3.47)$$

Denoting $\mathbf{M} = \mathbf{B}\mathbf{R}^{-1}\mathbf{B}^T$ and taking into account (3.47) into (3.46) yields:

$$\begin{cases} \underline{x}_2^* \mathbf{B}\mathbf{R}^{-1}\mathbf{B}^T \underline{x}_2 = \underline{x}_2^* \mathbf{A} \underline{x}_1 - \lambda \underline{x}_2^* \underline{x}_1 \\ \underline{x}_2^* \mathbf{A} = -\underline{x}_1^* \mathbf{Q} - \lambda^* \underline{x}_2^* \end{cases} \quad (3.48)$$

$$\Rightarrow \underline{x}_2^* \mathbf{M} \underline{x}_2 = -\underline{x}_1^* \mathbf{Q} \underline{x}_1 - \lambda^* \underline{x}_2^* \underline{x}_1 - \lambda \underline{x}_2^* \underline{x}_1 = -\underline{x}_1^* \mathbf{Q} \underline{x}_1 - (\lambda^* + \lambda) \underline{x}_2^* \underline{x}_1$$

Using (3.45) we finally get:

$$\underline{x}_2^* \mathbf{M} \underline{x}_2 = -\underline{x}_1^* \mathbf{Q} \underline{x}_1 \quad (3.49)$$

Since \mathbf{R} and \mathbf{Q} are positive semi-definite matrices, and consequently also $\mathbf{M} = \mathbf{B}\mathbf{R}^{-1}\mathbf{B}^T$, this implies:

$$\begin{cases} \mathbf{M} \underline{x}_2 = \underline{0} \\ \mathbf{Q} \underline{x}_1 = \underline{0} \end{cases} \quad (3.50)$$

Then using (3.46) we get:

$$\begin{cases} \mathbf{A} \underline{x}_1 = \lambda \underline{x}_1 \\ \mathbf{Q} \underline{x}_1 = \underline{0} \end{cases} \Rightarrow \begin{bmatrix} \mathbf{A} - \lambda \mathbb{I} \\ \mathbf{Q} \end{bmatrix} \underline{x}_1 = \underline{0} \quad (3.51)$$

If $\underline{x}_1 \neq \underline{0}$ then this contradicts observability of the pair (\mathbf{Q}, \mathbf{A}) by the Popov-Belevitch-Hautus test. Similarly if $\underline{x}_2 \neq \underline{0}$ then $\underline{x}_2^* [\mathbf{M} \ \mathbf{A} + \lambda^* \mathbb{I}] = \underline{0}$ which contradicts the observability of the pair (\mathbf{A}, \mathbf{M}) .

3.5.3 Solving general algebraic Riccati and Lyapunov equations

The general algebraic Riccati equation reads as follows where all matrices are square of dimension $n \times n$:

$$\mathbf{A}\mathbf{X} + \mathbf{X}\mathbf{B} + \mathbf{C} + \mathbf{X}\mathbf{D}\mathbf{X} = \mathbf{0} \quad (3.52)$$

Matrices \mathbf{A} , \mathbf{B} , \mathbf{C} and \mathbf{D} are known whereas matrix \mathbf{X} has to be determined.

The general algebraic Lyapunov equation is obtained as a special case of the algebraic Riccati by setting $\mathbf{D} = \mathbf{0}$.

The general algebraic Riccati equation can be solved³ by considering the following $2n \times 2n$ matrix \mathbf{H} :

$$\mathbf{H} = \begin{bmatrix} \mathbf{B} & \mathbf{D} \\ -\mathbf{C} & -\mathbf{A} \end{bmatrix} \quad (3.53)$$

Let the eigenvalues of matrix \mathbf{H} be denoted λ_i , $i = 1, \dots, 2n$, and the corresponding eigenvectors be denoted \underline{v}_i . Furthermore let \mathbf{M} be the $2n \times 2n$ matrix composed of all real eigenvectors of matrix \mathbf{H} ; for complex conjugate eigenvectors, the corresponding columns of matrix \mathbf{M} are changed into the real

³Optimal Control of Singularly Perturbed Linear Systems with Applications: High Accuracy Techniques, Z. Gajic and M. Lim, Marcel Dekker, New York, 2001

3.6 Application to the optimal control of any scalar LTI plant

We consider the following scalar linear time invariant plant where $x(t) \in \mathbb{R}$, $u(t) \in \mathbb{R}$:

$$\begin{cases} \dot{x}(t) = a x(t) + b u(t) & \text{where } b \neq 0 \\ z(t) = c_1 x(t) & \text{where } c_1 \neq 0 \end{cases} \quad (3.60)$$

We wish to minimize the following performance index:

$$J(u(t)) = \frac{1}{2} \int_0^\infty z^2(t) + \rho u^2(t) dt \quad \text{where } \rho > 0 \quad (3.61)$$

It is easy to check that pair (a, b) is controllable (meaning that $b \neq 0$) and that pair (a, c_1) is observable (meaning that $c_1 \neq 0$).

In order to match the considered performance index with the general expression $\frac{1}{2} \int_0^\infty (\underline{x}^T(t) \mathbf{Q} \underline{x}(t) + \underline{u}^T(t) \mathbf{R} \underline{u}(t)) dt$ of the performance index, we define weights \mathbf{Q} and \mathbf{R} as follows:

$$\begin{aligned} z^2(t) &= z^T(t)z(t) = (c_1 x(t))^T (c_1 x(t)) = x^T(t) c_1^T c_1 x(t) \\ \Rightarrow \begin{cases} \mathbf{Q} &:= c_1^T c_1 = c_1^2 \\ \mathbf{R} &:= \rho \end{cases} \end{aligned} \quad (3.62)$$

The Hamiltonian matrix \mathbf{H} reads:

$$\mathbf{H} = \begin{bmatrix} \mathbf{A} & -\mathbf{B}\mathbf{R}^{-1}\mathbf{B}^T \\ -\mathbf{Q} & -\mathbf{A}^T \end{bmatrix} \begin{bmatrix} x(t) \\ \lambda(t) \end{bmatrix} = \begin{bmatrix} a & -\frac{b^2}{\rho} \\ -c_1^2 & -a \end{bmatrix} \quad (3.63)$$

The eigenvalues of \mathbf{H} are obtained by solving:

$$\begin{aligned} \det(s\mathbb{I} - \mathbf{H}) &= 0 \Rightarrow \det \left(\begin{bmatrix} s - a & \frac{b^2}{\rho} \\ c_1^2 & s + a \end{bmatrix} \right) = 0 \\ \Leftrightarrow (s - a)(s + a) - \frac{(c_1 b)^2}{\rho} &= 0 \\ \Leftrightarrow s^2 - a^2 - \frac{(c_1 b)^2}{\rho} &= 0 \end{aligned} \quad (3.64)$$

Thus the two eigenvalues of \mathbf{H} read:

$$\begin{cases} \lambda_1 = +\sqrt{a^2 + \frac{(c_1 b)^2}{\rho}} \\ \lambda_2 = -\sqrt{a^2 + \frac{(c_1 b)^2}{\rho}} \end{cases} \quad (3.65)$$

We check that the eigenvalues of \mathbf{H} are symmetric with respect to the imaginary axis.

The eigenvectors \underline{v}_1 and \underline{v}_2 corresponding to eigenvalues λ_1 and λ_2 , respectively, are obtained as follows:

$$\begin{aligned} \mathbf{H}\underline{v}_1 &= \lambda_1 \underline{v}_1 \Rightarrow \begin{bmatrix} a & -\frac{b^2}{\rho} \\ -c_1^2 & -a \end{bmatrix} \begin{bmatrix} v_{11} \\ v_{12} \end{bmatrix} = \lambda_1 \begin{bmatrix} v_{11} \\ v_{12} \end{bmatrix} \\ \Leftrightarrow \begin{cases} a v_{11} - \frac{b^2}{\rho} v_{12} = \lambda_1 v_{11} \\ -c_1^2 v_{11} - a v_{12} = \lambda_1 v_{12} \end{cases} \\ \Leftrightarrow \begin{cases} v_{11} (a - \lambda_1) = \frac{b^2}{\rho} v_{12} \\ -c_1^2 v_{11} = v_{12} (a + \lambda_1) \end{cases} \end{aligned} \quad (3.66)$$

From the first equation we can choose for example the following components for eigenvector \underline{v}_1 :

$$\underline{v}_1 = \begin{bmatrix} v_{11} \\ v_{12} \end{bmatrix} = \begin{bmatrix} \frac{1}{a-\lambda_1} \\ \frac{\rho}{b^2} \end{bmatrix} \text{ where } \lambda_1 = +\sqrt{a^2 + \frac{(c_1 b)^2}{\rho}} \quad (3.67)$$

We can check that this choice for v_{11} and v_{12} is compatible with the second equation. Indeed:

$$-c_1^2 v_{11} = v_{12} (a + \lambda_1) \Rightarrow \frac{-c_1^2}{a-\lambda_1} = \frac{\rho}{b^2} (a + \lambda_1) \Rightarrow a^2 - \lambda_1^2 = -\frac{(c_1 b)^2}{\rho} \quad (3.68)$$

Changing λ_1 by λ_2 leads to a possible choice of the components of eigenvector \underline{v}_2 :

$$\underline{v}_2 = \begin{bmatrix} v_{21} \\ v_{22} \end{bmatrix} = \begin{bmatrix} \frac{1}{a-\lambda_2} \\ \frac{\rho}{b^2} \end{bmatrix} \text{ where } \lambda_2 = -\sqrt{a^2 + \frac{(c_1 b)^2}{\rho}} \quad (3.69)$$

As far as λ_2 is the eigenvalue of \mathbf{H} in the left half plane, we conclude that λ_2 will be the closed-loop eigenvalue once the optimal control has been applied (notice that we don't know so far the expression of the optimal control !).

As far as \underline{v}_2 is the eigenvector of \mathbf{H} corresponding to the eigenvalue in the left half plane, we split it as follows:

$$\underline{v}_2 = \begin{bmatrix} \mathbf{X}_1 \\ \mathbf{X}_2 \end{bmatrix} = \begin{bmatrix} \frac{1}{a-\lambda_2} \\ \frac{\rho}{b^2} \end{bmatrix} \text{ where } \lambda_2 = -\sqrt{a^2 + \frac{(c_1 b)^2}{\rho}} \quad (3.70)$$

Then the solution of the algebraic Riccati equation which leads to the computation of the optimal control reads:

$$\mathbf{P} = \mathbf{X}_2 \mathbf{X}_1^{-1} = \frac{\rho}{b^2} (a - \lambda_2) \text{ where } \lambda_2 = -\sqrt{a^2 + \frac{(c_1 b)^2}{\rho}} \quad (3.71)$$

Thus:

$$\mathbf{P} = \frac{\rho}{b^2} \left(a + \sqrt{a^2 + \frac{(c_1 b)^2}{\rho}} \right) \quad (3.72)$$

We will check those results by using the algebraic Riccati equation, which reads:

$$\begin{aligned} \mathbf{A}^T \mathbf{P} + \mathbf{P} \mathbf{A} - \mathbf{P} \mathbf{B} \mathbf{R}^{-1} \mathbf{B}^T \mathbf{P} + \mathbf{Q} &= \mathbf{0} \\ \Leftrightarrow 2a\mathbf{P} - \frac{b^2}{\rho} \mathbf{P}^2 + c_1^2 &= 0 \\ \Leftrightarrow \frac{b^2}{\rho} \mathbf{P}^2 - 2a\mathbf{P} - c_1^2 &= 0 \end{aligned} \quad (3.73)$$

The roots of this quadratic equation are:

$$\begin{cases} \mathbf{P}_1 = \frac{2a + \sqrt{4a^2 + 4\frac{(c_1 b)^2}{\rho}}}{2\frac{b^2}{\rho}} = \frac{\rho}{b^2} \left(a + \sqrt{a^2 + \frac{(c_1 b)^2}{\rho}} \right) > 0 \\ \mathbf{P}_2 = \frac{2a - \sqrt{4a^2 + 4\frac{(c_1 b)^2}{\rho}}}{2\frac{b^2}{\rho}} = \frac{\rho}{b^2} \left(a - \sqrt{a^2 + \frac{(c_1 b)^2}{\rho}} \right) < 0 \end{cases} \quad (3.74)$$

It is clear that \mathbf{P}_1 is the positive definite solution of the algebraic Riccati equation (ARE). Thus we retrieve the result (3.72):

$$\mathbf{P} := \mathbf{P}_1 = \frac{\rho}{b^2} \left(a + \sqrt{a^2 + \frac{(c_1 b)^2}{\rho}} \right) \quad (3.75)$$

Furthermore we are now in position to compute the feedback gain \mathbf{K} :

$$\mathbf{K} = \mathbf{R}^{-1} \mathbf{B}^T \mathbf{P} = \frac{b}{\rho} \frac{\rho}{b^2} \left(a + \sqrt{a^2 + \frac{(c_1 b)^2}{\rho}} \right) = \frac{1}{b} \left(a + \sqrt{a^2 + \frac{(c_1 b)^2}{\rho}} \right) \quad (3.76)$$

Finally, the eigenvalue of the feedback loop reads:

$$\begin{aligned} \text{spec}(\mathbf{A} - \mathbf{BK}) &= \mathbf{A} - \mathbf{BK} = a - b \frac{1}{b} \left(a + \sqrt{a^2 + \frac{(c_1 b)^2}{\rho}} \right) \\ &= -\sqrt{a^2 + \frac{(c_1 b)^2}{\rho}} \end{aligned} \quad (3.77)$$

We obviously retrieve the result (3.69) obtained through the Hamiltonian matrix \mathbf{H} .

3.7 Hamiltonian matrix properties

Let \mathbf{H} be the following Hamiltonian matrix:

$$\mathbf{H} = \begin{bmatrix} \mathbf{A} & -\mathbf{G} \\ -\mathbf{Q} & -\mathbf{A}^T \end{bmatrix} \quad \text{where } \mathbf{G} = \mathbf{G}^T, \quad \mathbf{Q} = \mathbf{Q}^T \quad (3.78)$$

By definition, a matrix \mathbf{H} is said to be an Hamiltonian matrix as soon as the following property holds:

$$(\mathbf{JH})^T = \mathbf{JH} \quad (3.79)$$

where \mathbf{J} is the following skew-symmetric matrix:

$$\mathbf{J} = -\mathbf{J}^T = \begin{bmatrix} \mathbf{0} & \mathbb{I} \\ -\mathbb{I} & \mathbf{0} \end{bmatrix} \quad (3.80)$$

Any matrix $\mathbf{S} \in \mathbb{R}^{2n \times 2n}$ satisfying the following relation is called a symplectic matrix:

$$\mathbf{S}^T \mathbf{J} \mathbf{S} = \mathbf{J} \quad (3.81)$$

If \mathbf{H} has no eigenvalues on the imaginary axis, then the invariant subspace \mathcal{X} belonging to the n (counting multiplicities) eigenvalues in the open left half plane is called the stable invariant subspace of \mathbf{H} . If the columns of \mathbf{X} form an orthonormal basis for \mathcal{X} , then $\begin{bmatrix} \mathbf{X} & \mathbf{JX} \end{bmatrix}$ is orthogonal and the following Hamiltonian block-Schur decomposition is obtained⁴:

$$\begin{bmatrix} \mathbf{X} & \mathbf{JX} \end{bmatrix}^T \mathbf{H} \begin{bmatrix} \mathbf{X} & \mathbf{JX} \end{bmatrix} = \begin{bmatrix} \mathbf{T} & -\mathbf{G} \\ \mathbf{0} & -\mathbf{T}^T \end{bmatrix} \quad (3.82)$$

⁴ Peter Benner, Daniel Kressner, Volker Mehrmann, Skew-Hamiltonian and Hamiltonian Eigenvalue Problems: Theory, Algorithms and Applications, January 2005, Proceedings of the Conference on Applied Mathematics and Scientific Computing (pp.3-39), DOI: 10.1007/1-4020-3197-1_1

where $\mathbf{T} \in \mathbb{R}^{n \times n}$ is an upper triangular matrix (we said that \mathbf{T} has a real Schur form):

$$\mathbf{T} = \begin{bmatrix} t_{11} & t_{12} & \cdots & t_{1n} \\ 0 & t_{21} & \ddots & \\ \vdots & \ddots & \ddots & \\ 0 & 0 & \cdots & t_{nn} \end{bmatrix} \quad (3.83)$$

Moreover, given Hamiltonian matrix \mathbf{H} defined in (3.78), there is always a corresponding algebraic Riccati equation (ARE)⁴:

$$\mathbf{H} = \begin{bmatrix} \mathbf{A} & -\mathbf{G} \\ -\mathbf{Q} & -\mathbf{A}^T \end{bmatrix} \text{ where } \mathbf{G} = \mathbf{G}^T, \quad \mathbf{Q} = \mathbf{Q}^T \quad (3.84)$$

Corresponding ARE : $\mathbf{A}^T \mathbf{P} + \mathbf{P} \mathbf{A} - \mathbf{P} \mathbf{G} \mathbf{P} + \mathbf{Q} = \mathbf{0}$

Assume that $\mathbf{P} = \mathbf{P}^T$ is a symmetric solution of the algebraic Riccati equation (ARE). Then it is easy to see that the following relation holds:

$$\mathbf{H} \begin{bmatrix} \mathbb{I}_n & \mathbf{0} \\ \mathbf{P} & \mathbb{I}_n \end{bmatrix} = \begin{bmatrix} \mathbb{I}_n & \mathbf{0} \\ \mathbf{P} & \mathbb{I}_n \end{bmatrix} \begin{bmatrix} \mathbf{A} - \mathbf{G} \mathbf{P} & -\mathbf{G} \\ \mathbf{0} & -(\mathbf{A} - \mathbf{G} \mathbf{P})^T \end{bmatrix} \quad (3.85)$$

Hence $\mathbf{H} \begin{bmatrix} \mathbb{I}_n \\ \mathbf{P} \end{bmatrix} = \begin{bmatrix} \mathbb{I}_n \\ \mathbf{P} \end{bmatrix} (\mathbf{A} - \mathbf{G} \mathbf{P})$. Thus the columns of $\begin{bmatrix} \mathbb{I}_n \\ \mathbf{P} \end{bmatrix}$ span the \mathbf{H} -invariant subspace corresponding to $\lambda(\mathbf{H}) \cap \lambda(\mathbf{A} - \mathbf{G} \mathbf{P})$. This implies that AREs can be solved by computing \mathbf{H} -invariant subspaces.

Finally, let $\mathbf{G} = \mathbf{B} \mathbf{R}^{-1} \mathbf{B}^T$ and $\mathbf{Q} = \mathbf{N}^T \mathbf{N}$. Thus Hamiltonian matrix (3.78) reads:

$$\begin{cases} \mathbf{G} = \mathbf{B} \mathbf{R}^{-1} \mathbf{B}^T \\ \mathbf{Q} = \mathbf{N}^T \mathbf{N} \end{cases} \Rightarrow \mathbf{H} = \begin{bmatrix} \mathbf{A} & -\mathbf{G} \\ -\mathbf{Q} & -\mathbf{A}^T \end{bmatrix} = \begin{bmatrix} \mathbf{A} & -\mathbf{B} \mathbf{R}^{-1} \mathbf{B}^T \\ -\mathbf{N}^T \mathbf{N} & -\mathbf{A}^T \end{bmatrix} \quad (3.86)$$

where $\mathbf{R} = \mathbf{R}^T > 0 \Rightarrow \mathbf{R} = (\mathbf{R}^{0.5})^T \mathbf{R}^{0.5}$ and $\mathbf{R}^{-0.5} = (\mathbf{R}^{-0.5})^T$.

Then $\mathbf{G} \mathbf{P} = \mathbf{B} \mathbf{R}^{-1} \mathbf{B}^T \mathbf{P} := \mathbf{B} \mathbf{K}$ where $\mathbf{K} = \mathbf{R}^{-1} \mathbf{B}^T \mathbf{P}$ and relation(3.85) reads as follows:

$$\begin{aligned} \begin{bmatrix} \mathbf{A} & -\mathbf{B} \mathbf{R}^{-1} \mathbf{B}^T \\ -\mathbf{N}^T \mathbf{N} & -\mathbf{A}^T \end{bmatrix} \begin{bmatrix} \mathbb{I}_n & \mathbf{0} \\ \mathbf{P} & \mathbb{I}_n \end{bmatrix} \\ = \begin{bmatrix} \mathbb{I}_n & \mathbf{0} \\ \mathbf{P} & \mathbb{I}_n \end{bmatrix} \begin{bmatrix} \mathbf{A} - \mathbf{B} \mathbf{K} & -\mathbf{B} \mathbf{R}^{-1} \mathbf{B}^T \\ \mathbf{0} & -(\mathbf{A} - \mathbf{B} \mathbf{K})^T \end{bmatrix} \end{aligned} \quad (3.87)$$

From the preceding relation, and using the fact that $\det \left(\begin{bmatrix} \mathbb{I}_n & \mathbf{0} \\ \mathbf{P} & \mathbb{I}_n \end{bmatrix} \right) = 1$, we get:

$$\det (s\mathbb{I} - \mathbf{H}) = (-1)^n \beta(s) \beta(-s) \text{ where } \beta(s) := \det (s\mathbb{I} - \mathbf{A} + \mathbf{B} \mathbf{K}) \quad (3.88)$$

Furthermore let $(\mathbf{A}, \mathbf{B}, \mathbf{N})$ be the realization of a strictly proper transfer matrix $\mathbf{F}(s)$:

$$\mathbf{F}(s) = \left(\frac{\mathbf{A} \mid \mathbf{B} \mathbf{R}^{-0.5}}{\mathbf{N} \mid \mathbf{0}} \right) := \mathbf{N} (s\mathbb{I} - \mathbf{A})^{-1} \mathbf{B} \mathbf{R}^{-0.5} \quad (3.89)$$

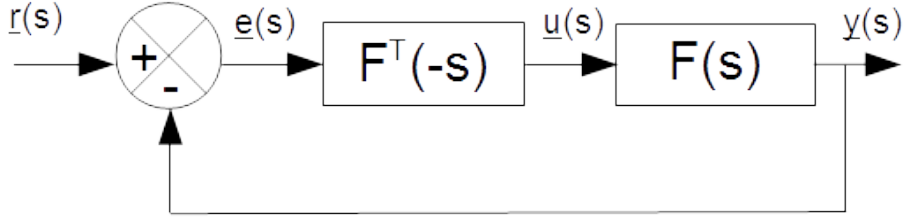

Figure 3.1: Closed-loop Hamiltonian transfer function

Then it can be shown that the following relation holds:

$$(\mathbb{I} + \mathbf{F}(s)\mathbf{F}^T(-s))^{-1} = \begin{bmatrix} -\mathbf{N} & \mathbf{0} \end{bmatrix} (s\mathbb{I} - \mathbf{H})^{-1} \begin{bmatrix} \mathbf{0} \\ \mathbf{N}^T \end{bmatrix} + \mathbb{I} \quad (3.90)$$

To get this result, consider Figure 3.1. The relation between $\underline{e}(s)$ and $\underline{r}(s)$ is obtained by reading Figure 3.1 *against* the arrows:

$$\begin{aligned} \underline{e}(s) &= \underline{r}(s) - \mathbf{F}(s)\mathbf{F}^T(-s)\underline{e}(s) \\ \Rightarrow \underline{e}(s) &= (\mathbb{I} + \mathbf{F}(s)\mathbf{F}^T(-s))^{-1} \underline{r}(s) \end{aligned} \quad (3.91)$$

On the other hand, the realization of $\mathbf{F}^T(-s)$ is obtained from the realization of $\mathbf{F}(s)$ as follows:

$$\begin{aligned} \mathbf{F}(s) &= \left(\begin{array}{c|c} \mathbf{A} & \mathbf{B}\mathbf{R}^{-0.5} \\ \mathbf{N} & \mathbf{0} \end{array} \right) := \mathbf{N}(s\mathbb{I} - \mathbf{A})^{-1} \mathbf{B}\mathbf{R}^{-0.5} \\ \Rightarrow \mathbf{F}^T(-s) &= \left(\mathbf{N}(-s\mathbb{I} - \mathbf{A})^{-1} \mathbf{B}\mathbf{R}^{-0.5} \right)^T = -\mathbf{R}^{-0.5} \mathbf{B}^T (s\mathbb{I} - (-\mathbf{A}^T))^{-1} \mathbf{N}^T \\ &= \left(\begin{array}{c|c} -\mathbf{A}^T & \mathbf{N}^T \\ \hline -\mathbf{R}^{-0.5} \mathbf{B}^T & \mathbf{0} \end{array} \right) \end{aligned} \quad (3.92)$$

Thus, in the time domain we have:

$$\begin{cases} \mathbf{F}(s) = \left(\begin{array}{c|c} \mathbf{A} & \mathbf{B}\mathbf{R}^{-0.5} \\ \mathbf{N} & \mathbf{0} \end{array} \right) \Rightarrow \begin{cases} \dot{\underline{x}}_1 = \mathbf{A}\underline{x}_1 + \mathbf{B}\mathbf{R}^{-0.5}\underline{u} \\ \underline{y} = \mathbf{N}\underline{x}_1 \end{cases} \\ \mathbf{F}^T(-s) = \left(\begin{array}{c|c} -\mathbf{A}^T & \mathbf{N}^T \\ \hline -\mathbf{R}^{-0.5} \mathbf{B}^T & \mathbf{0} \end{array} \right) \Rightarrow \begin{cases} \dot{\underline{x}}_2 = -\mathbf{A}^T \underline{x}_2 + \mathbf{N}^T \underline{e} \\ \underline{u} = -\mathbf{R}^{-0.5} \mathbf{B}^T \underline{x}_2 \end{cases} \end{cases} \quad (3.93)$$

From Figure 3.1 we see that $\underline{e} = \underline{r} - \underline{y}$. Thus the realization of Figure 3.1 reads as follows:

$$\begin{cases} \underline{e} = \underline{r} - \underline{y} \\ \underline{u} = -\mathbf{R}^{-0.5} \mathbf{B}^T \underline{x}_2 \\ \underline{y} = \mathbf{N}\underline{x}_1 \end{cases} \Rightarrow \begin{cases} \begin{bmatrix} \dot{\underline{x}}_1 \\ \dot{\underline{x}}_2 \end{bmatrix} = \begin{bmatrix} \mathbf{A} & -\mathbf{B}\mathbf{R}^{-1} \mathbf{B}^T \\ -\mathbf{N}^T \mathbf{N} & -\mathbf{A}^T \end{bmatrix} \begin{bmatrix} \underline{x}_1 \\ \underline{x}_2 \end{bmatrix} + \begin{bmatrix} \mathbf{0} \\ \mathbf{N}^T \end{bmatrix} \underline{r} \\ \underline{e} = \begin{bmatrix} -\mathbf{N} & \mathbf{0} \end{bmatrix} \begin{bmatrix} \underline{x}_1 \\ \underline{x}_2 \end{bmatrix} + \mathbb{I} \underline{r} \end{cases} \quad (3.94)$$

In the frequency domain we get:

$$\underline{e}(s) = \left(\begin{bmatrix} -\mathbf{N} & \mathbf{0} \end{bmatrix} (s\mathbb{I} - \mathbf{H})^{-1} \begin{bmatrix} \mathbf{0} \\ \mathbf{N}^T \end{bmatrix} + \mathbb{I} \right) \underline{r}(s) \quad (3.95)$$

When identifying (3.91) with (3.95) we get relation (3.90). An alternate relation can also be obtained by replacing $\mathbf{F}^T(-s)\mathbf{F}(s)$ in Figure 3.1 by $\mathbf{F}(s)\mathbf{F}^T(-s)$. Then we get:

$$(\mathbb{I} + \mathbf{F}^T(-s)\mathbf{F}(s))^{-1} = \begin{bmatrix} \mathbf{0} & -\mathbf{R}^{-0.5}\mathbf{B}^T \end{bmatrix} (s\mathbb{I} - \mathbf{H})^{-1} \begin{bmatrix} \mathbf{B}\mathbf{R}^{-0.5} \\ \mathbf{0} \end{bmatrix} + \mathbb{I} \quad (3.96)$$

Having in mind that for any square invertible matrix \mathbf{Y} we have $\mathbf{X}\mathbf{Y}^{-1}\mathbf{Z} = \frac{\mathbf{X}\text{adj}(\mathbf{Y})\mathbf{Z}}{\det(\mathbf{Y})}$ (here $\mathbf{X} = \begin{bmatrix} \mathbf{0} & -\mathbf{R}^{-0.5}\mathbf{B}^T \end{bmatrix}$, $\mathbf{Y} = (s\mathbb{I} - \mathbf{H})$ and $\mathbf{Z} = \begin{bmatrix} \mathbf{B}\mathbf{R}^{-0.5} \\ \mathbf{0} \end{bmatrix}$), we conclude that relation (3.90) indicates that the eigenvalues of Hamiltonian matrix \mathbf{H} are the roots of $\det(\mathbb{I} + \mathbf{F}(s)\mathbf{F}^T(-s))$.

Moreover, let:

$$\mathbf{F}(s) = \mathbf{N}(s\mathbb{I} - \mathbf{A})^{-1}\mathbf{B}\mathbf{R}^{-0.5} = \frac{\mathbf{N}\text{adj}(s\mathbb{I} - \mathbf{A})\mathbf{B}\mathbf{R}^{-0.5}}{\det(s\mathbb{I} - \mathbf{A})} := \frac{\mathbf{N}_{ol}(s)}{D(s)} \quad (3.97)$$

Then:

$$\begin{aligned} \det(\mathbb{I} + \mathbf{F}(s)\mathbf{F}^T(-s)) &= \det\left(\mathbb{I} + \frac{\mathbf{N}_{ol}(s)\mathbf{N}_{ol}^T(-s)}{D(s)D(-s)}\right) \\ &= \det\left(\frac{D(s)D(-s)\mathbb{I} + \mathbf{N}_{ol}(s)\mathbf{N}_{ol}^T(-s)}{D(s)D(-s)}\right) \end{aligned} \quad (3.98)$$

Consequently, the eigenvalues of the Hamiltonian matrix \mathbf{H} are the roots of $\det(D(s)D(-s)\mathbb{I} + \mathbf{N}_{ol}(s)\mathbf{N}_{ol}^T(-s))$:

$$\boxed{\det(s\mathbb{I} - \mathbf{H})|_{s=\lambda} = 0 \Leftrightarrow \det(D(s)D(-s)\mathbb{I} + \mathbf{N}_{ol}(s)\mathbf{N}_{ol}^T(-s))|_{s=\lambda} = 0} \quad (3.99)$$

Alternatively, the preceding relation indicates that $D(\lambda)D(-\lambda)$ is an eigenvalue of matrix $-\mathbf{N}_{ol}(\lambda)\mathbf{N}_{ol}^T(-\lambda)$. This remark may be used for design purposes, especially to select matrix \mathbf{N} to achieve some specified closed-loop eigenvalues (we recall that weighting matrix \mathbf{Q} is given by $\mathbf{Q} = \mathbf{N}^T\mathbf{N}$).

3.8 Discrete time LQ regulator

3.8.1 Finite horizon LQ regulator

There is an equivalent theory for discrete time systems. Indeed, for the system:

$$\begin{cases} \underline{x}(k+1) = \mathbf{A}\underline{x}(k) + \mathbf{B}\underline{u}(k) \\ \underline{x}(0) = \underline{x}_0 \end{cases} \quad (3.100)$$

with an equivalent performance criteria:

$$J(\underline{u}(k)) = \frac{1}{2}\underline{x}^T(N)\mathbf{S}\underline{x}(N) + \frac{1}{2}\sum_{k=0}^{N-1}\underline{x}^T(k)\mathbf{Q}\underline{x}(k) + \underline{u}^T(k)\mathbf{R}\underline{u}(k) \quad (3.101)$$

Where $\mathbf{Q} \geq 0$ is a constant positive definite matrix and $\mathbf{R} > 0$ a constant positive definite matrix. The optimal control is given by:

$$\underline{u}(k) = -\mathbf{K}(k)\underline{x}(k) \quad (3.102)$$

Where:

$$\mathbf{K}(k) = (\mathbf{R} + \mathbf{B}^T \mathbf{P}(k+1) \mathbf{B})^{-1} \mathbf{B}^T \mathbf{P}(k+1) \mathbf{A} \quad (3.103)$$

And $\mathbf{P}(k)$ is given by the solution of the discrete time Riccati equation:

$$\begin{cases} \mathbf{P}(k) = \mathbf{A}^T \mathbf{P}(k+1) \mathbf{A} + \mathbf{Q} - \mathbf{A}^T \mathbf{P}(k+1) \mathbf{B} (\mathbf{R} + \mathbf{B}^T \mathbf{P}(k+1) \mathbf{B})^{-1} \mathbf{B}^T \mathbf{P}(k+1) \mathbf{A} \\ \mathbf{P}(N) = \mathbf{S} \end{cases} \quad (3.104)$$

3.8.2 Finite horizon LQ regulator with zero terminal state

We consider the following performance criteria to be minimized:

$$J(\underline{u}(k)) = \frac{1}{2} \sum_{k=0}^{N-1} \underline{x}^T(k) \mathbf{Q} \underline{x}(k) + \underline{u}^T(k) \mathbf{R} \underline{u}(k) + 2 \underline{x}^T(k) \mathbf{S} \underline{u}(k) \quad (3.105)$$

With the constraint on terminal state:

$$\underline{x}(N) = \underline{0} \quad (3.106)$$

We will assume that matrices $\mathbf{R} > 0$ and $\mathbf{Q} - \mathbf{S} \mathbf{R}^{-1} \mathbf{S}^T \geq 0$ are symmetric. Ntogramatzidis² has shown the results presented hereafter: denote by \mathbf{P}_1 and \mathbf{P}_2 the positive definite solutions of the following continuous time algebraic Riccati equations:

$$\begin{cases} \mathbf{0} = \mathbf{P}_1 + (\mathbf{A}^T \mathbf{P}_1 \mathbf{B} + \mathbf{S}) (\mathbf{R} + \mathbf{B}^T \mathbf{P}_1 \mathbf{B})^{-1} (\mathbf{B}^T \mathbf{P}_1 \mathbf{A} + \mathbf{S}^T) \\ \quad - \mathbf{A}^T \mathbf{P}_1 \mathbf{A} - \mathbf{Q} \\ \mathbf{0} = \mathbf{P}_2 + (\mathbf{A}_b^T \mathbf{P}_2 \mathbf{B}_b + \mathbf{S}_b) (\mathbf{R}_b + \mathbf{B}_b^T \mathbf{P}_2 \mathbf{B}_b)^{-1} (\mathbf{B}_b^T \mathbf{P}_2 \mathbf{A}_b + \mathbf{S}_b^T) \\ \quad - \mathbf{A}_b^T \mathbf{P}_2 \mathbf{A}_b - \mathbf{Q}_b \end{cases} \quad (3.107)$$

Where:

$$\begin{cases} \mathbf{A}_b = \mathbf{A}^{-1} \\ \mathbf{B}_b = -\mathbf{A}^{-1} \mathbf{B} \\ \mathbf{Q}_b = \mathbf{A}^{-T} \mathbf{Q} \mathbf{A}^{-1} \\ \mathbf{R}_b = \mathbf{R} - \mathbf{S}^T \mathbf{A}^{-1} \mathbf{B} - \mathbf{B}^T \mathbf{A}^{-T} \mathbf{S} + \mathbf{B}^T \mathbf{A}^{-T} \mathbf{Q} \mathbf{A}^{-1} \mathbf{B} \\ \mathbf{S}_b = \mathbf{A}^{-T} \mathbf{S} - \mathbf{A}^{-T} \mathbf{Q} \mathbf{A}^{-1} \mathbf{B} \end{cases} \quad (3.108)$$

We will denote by \mathbf{K}_1 and \mathbf{K}_2 the following *infinite* horizon gain matrices:

$$\begin{cases} \mathbf{K}_1 = (\mathbf{R} + \mathbf{B}^T \mathbf{P}_1 \mathbf{B})^{-1} (\mathbf{B}^T \mathbf{P}_1 \mathbf{A} + \mathbf{S}^T) \\ \mathbf{K}_2 = (\mathbf{R}_b + \mathbf{B}_b^T \mathbf{P}_2 \mathbf{B}_b)^{-1} (\mathbf{B}_b^T \mathbf{P}_2 \mathbf{A}_b + \mathbf{S}_b^T) \end{cases} \quad (3.109)$$

Then the optimal control is:

$$\underline{u}(k) = \begin{cases} -\mathbf{K}(k) \underline{x}(k) \quad \forall 0 \leq k < N \\ 0 \quad \text{for } k = N \end{cases} \quad (3.110)$$

Where:

$$\begin{cases} \mathbf{K}(k) = (\mathbf{R} + \mathbf{B}^T \mathbf{P}(k+1) \mathbf{B})^{-1} (\mathbf{B}^T \mathbf{P}(k+1) \mathbf{A} + \mathbf{S}^T) \\ \mathbf{P}(k) = \mathbf{X}_2(k) \mathbf{X}_1^{-1}(k) \end{cases} \quad (3.111)$$

And:

$$\begin{cases} \mathbf{X}_1(k) = (\mathbf{A} - \mathbf{BK}_1)^k - (\mathbf{A}_b - \mathbf{B}_b\mathbf{K}_2)^{(k-N)} (\mathbf{A} - \mathbf{BK}_1)^N \\ \mathbf{X}_2(k) = \mathbf{P}_1 (\mathbf{A} - \mathbf{BK}_1)^k + \mathbf{P}_2 (\mathbf{A}_b - \mathbf{B}_b\mathbf{K}_2)^{(k-N)} (\mathbf{A} - \mathbf{BK}_1)^N \end{cases} \quad (3.112)$$

Matrix $\mathbf{P}(k)$ satisfy the following Riccati difference equation:

$$\begin{aligned} \mathbf{P}(k) + (\mathbf{A}^T \mathbf{P}(k+1) \mathbf{B} + \mathbf{S}) (\mathbf{R} + \mathbf{B}^T \mathbf{P}(k+1) \mathbf{B})^{-1} (\mathbf{B}^T \mathbf{P}(k+1) \mathbf{A} + \mathbf{S}^T) \\ - \mathbf{A}^T \mathbf{P}(k+1) \mathbf{A} - \mathbf{Q} = 0 \end{aligned} \quad (3.113)$$

Furthermore the optimal state $\underline{x}(k)$ and costate $\lambda(k)$ have the following expressions:

$$\begin{cases} \underline{x}(k+1) = (\mathbf{A} - \mathbf{BK}_1) e_1(k) - (\mathbf{A}_b - \mathbf{B}_b\mathbf{K}_2) e_2(k) \\ \lambda(k+1) = \mathbf{P}_1 (\mathbf{A} - \mathbf{BK}_1) e_1(k) + \mathbf{P}_2 (\mathbf{A}_b - \mathbf{B}_b\mathbf{K}_2) e_2(k) \end{cases} \quad (3.114)$$

Where:

$$\begin{cases} e_1(k) = (\mathbf{A} - \mathbf{BK}_1)^k \mathbf{X}_1^{-1}(0) \underline{x}_0 \\ e_2(k) = (\mathbf{A}_b - \mathbf{B}_b\mathbf{K}_2)^{(k-N)} (\mathbf{A} - \mathbf{BK}_1)^N \mathbf{X}_1^{-1}(0) \underline{x}_0 \end{cases} \quad (3.115)$$

3.8.3 Infinite horizon LQ regulator

For the infinite horizon problem $N \rightarrow \infty$. We will assume that the performance criteria to be minimized is:

$$J(\underline{u}(k)) = \frac{1}{2} \sum_{k=0}^{\infty} \underline{x}^T(k) \mathbf{Q} \underline{x}(k) + \underline{u}^T(k) \mathbf{R} \underline{u}(k) \quad (3.116)$$

Then matrix \mathbf{P} satisfies the following discrete time algebraic Riccati equation:

$$\mathbf{P} + \mathbf{A}^T \mathbf{P} \mathbf{B} (\mathbf{R} + \mathbf{B}^T \mathbf{P} \mathbf{B})^{-1} \mathbf{B}^T \mathbf{P} \mathbf{A} - \mathbf{A}^T \mathbf{P} \mathbf{A} - \mathbf{Q} = \mathbf{0} \quad (3.117)$$

And the discrete time control $\underline{u}(k)$ is given by:

$$\underline{u}(k) = -\mathbf{K} \underline{x}(k) \quad (3.118)$$

Where:

$$\mathbf{K} = (\mathbf{R} + \mathbf{B}^T \mathbf{P} \mathbf{B})^{-1} \mathbf{B}^T \mathbf{P} \mathbf{A} \quad (3.119)$$

If (\mathbf{A}, \mathbf{B}) is stabilizable, then the closed-loop system is stable, meaning that all the eigenvalues of $(\mathbf{A} - \mathbf{BK})$, with \mathbf{K} given by (3.119), will lie within the unit disk (i.e. have magnitudes less than 1). Let's define the following symplectic matrix⁵:

$$\mathbf{H} = \begin{bmatrix} \mathbf{A}^{-1} & \mathbf{A}^{-1} \mathbf{G} \\ \mathbf{Q} \mathbf{A}^{-1} & \mathbf{A}^T + \mathbf{Q} \mathbf{A}^{-1} \mathbf{G} \end{bmatrix} \quad (3.120)$$

⁵Alan J. Laub, A Schur Method for Solving Algebraic Riccati equations, IEEE Transactions On Automatic Control, VOL. AC-24, NO. 6, December 1979

Where:

$$\mathbf{G} = \mathbf{B}\mathbf{R}^{-1}\mathbf{B}^T \quad (3.121)$$

A symplectic matrix is a matrix which satisfies:

$$\mathbf{H}^T\mathbf{J}\mathbf{H} = \mathbf{J} \text{ where } \mathbf{J} = \begin{bmatrix} 0 & \mathbb{I} \\ -\mathbb{I} & 0 \end{bmatrix} \text{ and } \mathbf{J}^{-1} = -\mathbf{J} \quad (3.122)$$

This implies:

$$\begin{aligned} \mathbf{H}^T\mathbf{J} &= \mathbf{J}\mathbf{H}^{-1} \Leftrightarrow \mathbf{J}^{-1}\mathbf{H}^T\mathbf{J} = \mathbf{H}^{-1} \\ \Rightarrow \mathbf{H}^{-1} &= \begin{bmatrix} \mathbf{A} + \mathbf{G}\mathbf{A}^{-T}\mathbf{Q} & -\mathbf{G}\mathbf{A}^{-T} \\ -\mathbf{A}^{-T}\mathbf{Q} & \mathbf{A}^{-T} \end{bmatrix} \end{aligned} \quad (3.123)$$

Where $\mathbf{A}^{-T} = (\mathbf{A}^{-1})^T$. Under detectability and stabilizability assumptions, it can be shown that the eigenvalues of the closed-loop plant (that are the eigenvalues of $\mathbf{A} - \mathbf{B}\mathbf{K}$) are equal to the n eigenvalues inside the unit circle of the Hamiltonian matrix \mathbf{H} . The optimal control stabilizes the plant. Furthermore if the $2n \times n$ matrix $\begin{bmatrix} \mathbf{X}_1 \\ \mathbf{X}_2 \end{bmatrix}$ has columns that comprise all the eigenvectors associated with the n eigenvalues of the Hamiltonian matrix \mathbf{H} outside the unit circle (unstable eigenvalues) then \mathbf{X}_1 is invertible and the positive definite solution of the *algebraic Riccati equation (ARE)* is:

$$\mathbf{P} = \mathbf{X}_2\mathbf{X}_1^{-1} \quad (3.124)$$

Thus matrix \mathbf{P} for the optimal steady state feedback can be computed thanks to the unstable (eigenvalues outside the unit circle) eigenvectors of \mathbf{H} or the stable (eigenvalues inside the unit circle) eigenvectors of \mathbf{H}^{-1} .

3.9 Robustness property

3.9.1 Hsu-Chen theorem

Let's consider a linear plant controlled through a state feedback as follows:

$$\begin{cases} \dot{\underline{x}}(t) = \mathbf{A}\underline{x}(t) + \mathbf{B}\underline{u}(t) \\ \underline{u}(t) = -\mathbf{K}\underline{x}(t) + r(t) \end{cases} \quad (3.125)$$

The dynamics of the closed-loop system reads:

$$\dot{\underline{x}}(t) = (\mathbf{A} - \mathbf{B}\mathbf{K})\underline{x}(t) + \mathbf{B}r(t) \quad (3.126)$$

In order to compute the closed-loop transfer matrix between $\underline{X}(s)$ and $R(s)$ we take the Laplace transform of (3.125) assuming no initial condition:

$$\begin{aligned} s\underline{X}(s) &= \mathbf{A}\underline{X}(s) + \mathbf{B}(-\mathbf{K}\underline{X}(s) + R(s)) \\ \Rightarrow \underline{X}(s)(s\mathbb{I} - \mathbf{A} + \mathbf{B}\mathbf{K}) &= \mathbf{B}R(s) \\ \Rightarrow \underline{X}(s) &= (s\mathbb{I} - \mathbf{A} + \mathbf{B}\mathbf{K})^{-1}\mathbf{B}R(s) \end{aligned} \quad (3.127)$$

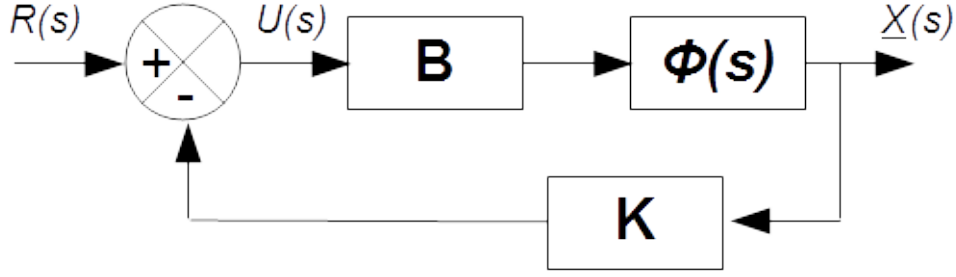

Figure 3.2: Full-state feedback control

On the other hand, let $\Phi(s)$ be resolvent of the state (transition) matrix \mathbf{A} . Matrix $\Phi(s)$ is defined as follows:

$$\Phi(s) = (s\mathbb{I} - \mathbf{A})^{-1} \quad (3.128)$$

The block diagram of the full-state feedback control is shown in Figure 3.2. We get:

$$\begin{aligned} \underline{X}(s) &= \Phi(s)\mathbf{B}(R(s) - \mathbf{K}\underline{X}(s)) \\ &= (\mathbb{I} + \Phi(s)\mathbf{B}\mathbf{K})^{-1}\Phi(s)\mathbf{B}R(s) \end{aligned} \quad (3.129)$$

Using the fact that $(\mathbf{A}\mathbf{B})^{-1} = \mathbf{B}^{-1}\mathbf{A}^{-1}$ we get:

$$\begin{aligned} \underline{X}(s) &= (\Phi^{-1}(s)(\mathbb{I} + \Phi(s)\mathbf{B}\mathbf{K}))^{-1}\mathbf{B}R(s) \\ &= (\Phi^{-1}(s) + \mathbf{B}\mathbf{K})^{-1}\mathbf{B}R(s) \\ &= (s\mathbb{I} - \mathbf{A} + \mathbf{B}\mathbf{K})^{-1}\mathbf{B}R(s) \end{aligned} \quad (3.130)$$

The open-loop characteristic polynomial is given by:

$$\det(s\mathbb{I} - \mathbf{A}) = \det(\Phi^{-1}(s)) \quad (3.131)$$

Whereas the closed-loop characteristic polynomial is given by:

$$\det(s\mathbb{I} - \mathbf{A} + \mathbf{B}\mathbf{K}) \quad (3.132)$$

Sylvester's determinant theorem⁶ states that the following relation holds where \mathbf{M}_1 is an $m \times n$ matrix and \mathbf{M}_2 an $n \times m$ matrix (so that \mathbf{M}_1 and \mathbf{M}_2 have dimensions allowing them to be multiplied in either order forming a square matrix):

$$\det(\mathbb{I}_m + \mathbf{M}_1\mathbf{M}_2) = \det(\mathbb{I}_n + \mathbf{M}_2\mathbf{M}_1) \quad (3.133)$$

Sylvester's determinant theorem may be proven using the Schur's formula, which is recalled hereafter:

$$\begin{aligned} \det\left(\begin{bmatrix} \mathbf{A}_{11} & \mathbf{A}_{12} \\ \mathbf{A}_{21} & \mathbf{A}_{22} \end{bmatrix}\right) &= \det(\mathbf{A}_{22}) \det(\mathbf{A}_{11} - \mathbf{A}_{12}\mathbf{A}_{22}^{-1}\mathbf{A}_{21}) \\ &= \det(\mathbf{A}_{11}) \det(\mathbf{A}_{22} - \mathbf{A}_{21}\mathbf{A}_{11}^{-1}\mathbf{A}_{12}) \end{aligned} \quad (3.134)$$

⁶<https://en.wikipedia.org/wiki/Determinant>

Thus if $\mathbf{M} = \begin{bmatrix} \mathbb{I}_m & -\mathbf{M}_1 \\ \mathbf{M}_2 & \mathbb{I}_n \end{bmatrix}$, we get:

$$\begin{aligned} \det(\mathbf{M}) &= \det \left(\begin{bmatrix} \mathbb{I}_m & -\mathbf{M}_1 \\ \mathbf{M}_2 & \mathbb{I}_n \end{bmatrix} \right) = \det(\mathbb{I}_m + \mathbf{M}_1 \mathbf{M}_2) \\ &= \det(\mathbb{I}_n + \mathbf{M}_2 \mathbf{M}_1) \end{aligned} \quad (3.135)$$

In addition, for square matrices \mathbf{M}_3 and \mathbf{M}_4 of equal size, the determinant of the matrix product equals the product of their determinants:

$$\det(\mathbf{M}_3 \mathbf{M}_4) = \det(\mathbf{M}_3) \det(\mathbf{M}_4) \quad (3.136)$$

Then we get:

$$\begin{aligned} \det(s\mathbb{I} - \mathbf{A} + \mathbf{BK}) &= \det \left((s\mathbb{I} - \mathbf{A}) \left(\mathbb{I} + (s\mathbb{I} - \mathbf{A})^{-1} \mathbf{BK} \right) \right) \\ &= \det \left((s\mathbb{I} - \mathbf{A}) \left(\mathbb{I} + \Phi(s) \mathbf{BK} \right) \right) \\ &= \det(s\mathbb{I} - \mathbf{A}) \det(\mathbb{I} + \Phi(s) \mathbf{BK}) \\ &= \det(s\mathbb{I} - \mathbf{A}) \det(\mathbb{I} + \mathbf{K} \Phi(s) \mathbf{B}) \end{aligned} \quad (3.137)$$

We finally get the following relation, which is known as the Hsu-Chen theorem⁷:

$$\boxed{\det(s\mathbb{I} - \mathbf{A} + \mathbf{BK}) = \det(s\mathbb{I} - \mathbf{A}) \det(\mathbb{I} + \mathbf{K} \Phi(s) \mathbf{B})} \quad (3.138)$$

The roots of $\det(s\mathbb{I} - \mathbf{A} + \mathbf{BK})$ are the eigenvalues of the closed-loop system. Consequently they are related to the stability of the closed-loop system.

Moreover the roots of $\det(\mathbb{I} + \mathbf{K} \Phi(s) \mathbf{B})$ are exactly the roots of $\det(s\mathbb{I} - \mathbf{A} + \mathbf{BK})$. Indeed, as far as $\Phi(s) = (s\mathbb{I} - \mathbf{A})^{-1}$, the inverse of $(s\mathbb{I} - \mathbf{A})$ is computed as the adjugate of matrix $(s\mathbb{I} - \mathbf{A})$ divided by $\det(s\mathbb{I} - \mathbf{A})$ which finally becomes the denominator of $\det(\mathbb{I} + \mathbf{K} \Phi(s) \mathbf{B})$:

$$\begin{aligned} \det(\mathbb{I} + \mathbf{K} \Phi(s) \mathbf{B}) &= \det \left(\mathbb{I} + \mathbf{K} (s\mathbb{I} - \mathbf{A})^{-1} \mathbf{B} \right) \\ &= \det \left(\mathbb{I} + \mathbf{K} \frac{\text{adj}(s\mathbb{I} - \mathbf{A})}{\det(s\mathbb{I} - \mathbf{A})} \mathbf{B} \right) \\ &= \det \left(\frac{\det(s\mathbb{I} - \mathbf{A}) \mathbb{I} + \mathbf{K} \text{adj}(s\mathbb{I} - \mathbf{A}) \mathbf{B}}{\det(s\mathbb{I} - \mathbf{A})} \right) \\ &= \frac{\det(\det(s\mathbb{I} - \mathbf{A}) \mathbb{I} + \mathbf{K} \text{adj}(s\mathbb{I} - \mathbf{A}) \mathbf{B})}{\det(s\mathbb{I} - \mathbf{A})} \\ \Rightarrow \det(s\mathbb{I} - \mathbf{A} + \mathbf{BK}) &= \det(\det(s\mathbb{I} - \mathbf{A}) \mathbb{I} + \mathbf{K} \text{adj}(s\mathbb{I} - \mathbf{A}) \mathbf{B}) \end{aligned} \quad (3.139)$$

Thus:

$$\det(s\mathbb{I} - \mathbf{A} + \mathbf{BK}) = 0 \Leftrightarrow \det(\mathbb{I} + \mathbf{K} \Phi(s) \mathbf{B}) = 0 \quad (3.140)$$

Consequently, the eigenvalues of full-state feedback loop are the roots of $\det(\mathbb{I} + \mathbf{K} \Phi(s) \mathbf{B})$.

⁷Pole-shifting techniques for multivariable feedback systems, Retallack D.G., MacFarlane A.G.J., Proceedings of the Institution of Electrical Engineers, 1970

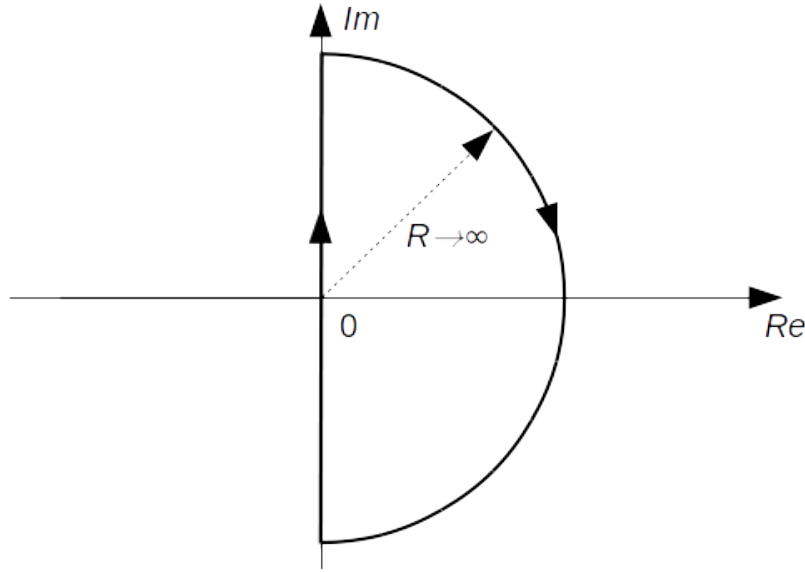

Figure 3.3: Nyquist contour

3.9.2 Generalized (MIMO) Nyquist stability criterion

Let's recall the generalized (MIMO) Nyquist stability criterion which will be applied in the next section to the LQR design through Kalman equality.

We remind that the Nyquist plot of $\det(\mathbb{I} + \mathbf{K}\Phi(s)\mathbf{B})$ is the image of $\det(\mathbb{I} + \mathbf{K}\Phi(s)\mathbf{B})$ as s goes clockwise around the Nyquist contour: this includes the entire imaginary axis ($s = j\omega$) and an infinite semi-circle around the right half plane as shown in Figure 3.3.

The generalized (MIMO) Nyquist stability criterion states that the number of unstable closed-loop poles (that are the roots of $\det(s\mathbb{I} - \mathbf{A} + \mathbf{B}\mathbf{K})$) is equal to the number of unstable open-loop poles (that are the roots of $\det(s\mathbb{I} - \mathbf{A})$) plus the number of encirclements of the critical point $(0, 0)$ by the Nyquist plot of $\det(\mathbb{I} + \mathbf{K}\Phi(s)\mathbf{B})$; the encirclement is counted positive in the clockwise direction and negative otherwise.

An easy way to determine the number of encirclements of the critical point is to draw a line out from the critical point, in any directions. Then by counting the number of times that the Nyquist plot crosses the line in the clockwise direction (i.e. left to right) and by subtracting the number of times it crosses in the counterclockwise direction then the number of clockwise encirclements of the critical point is obtained. A negative number indicates counterclockwise encirclements.

It is worth noticing that for Single-Input Single-Output (SISO) systems \mathbf{K} is a row vector whereas \mathbf{B} is a column vector. Consequently $\mathbf{K}\Phi(s)\mathbf{B}$ is a scalar and we have:

$$\det(\mathbb{I} + \mathbf{K}\Phi(s)\mathbf{B}) = \det(1 + \mathbf{K}\Phi(s)\mathbf{B}) = 1 + \mathbf{K}\Phi(s)\mathbf{B} \quad (3.141)$$

Thus for Single-Input Single-Output (SISO) systems the number of encirclements of the critical point $(0, 0)$ by the Nyquist plot of

$\det(\mathbb{I} + \mathbf{K}\Phi(s)\mathbf{B})$ is equivalent to the number of encirclements of the critical point $(-1, 0)$ by the Nyquist plot of $\mathbf{K}\Phi(s)\mathbf{B}$.

In the context of output feedback the control $u(t) = -\mathbf{K}\underline{x}(t)$ is replaced by $u(t) = -\mathbf{K}y(t)$ where $y(t)$ is the output of the plant: $y(t) = \mathbf{C}\underline{x}(t)$. As a consequence the control $u(t)$ reads $u(t) = -\mathbf{K}\mathbf{C}\underline{x}(t)$ and state feedback gain \mathbf{K} is replaced by output feedback gain $\mathbf{K}\mathbf{C}$ in equation (3.138):

$$\det(s\mathbb{I} - \mathbf{A} + \mathbf{B}\mathbf{K}\mathbf{C}) = \det(s\mathbb{I} - \mathbf{A}) \det(\mathbb{I} + \mathbf{K}\mathbf{C}\Phi(s)\mathbf{B}) \quad (3.142)$$

This equation involves the transfer function $\mathbf{C}\Phi(s)\mathbf{B}$ between the output $Y(s)$ and the control $U(s)$ of the plant without any feedback and is used in the Nyquist stability criterion for Single-Input Single-Output (SISO) systems.

It is also worth noticing that $(\mathbb{I} + \mathbf{K}\mathbf{C}\Phi(s)\mathbf{B})^{-1}$ is attached to the so called sensitivity function of the closed-loop whereas $\mathbf{C}\Phi(s)\mathbf{B}$ is attached to the open-loop transfer function from the process' input $\underline{U}(s)$ to the plant output $\underline{Y}(s)$.

3.9.3 Kalman equality

Let's consider the full-state feedback control is shown in Figure 3.2. Kalman has shown the following result, known as *Kalman equality*:

$$\boxed{(\mathbb{I} + \mathbf{L}(-s))^T \mathbf{R} (\mathbb{I} + \mathbf{L}(s)) = \mathbf{R} + (\Phi(-s)\mathbf{B})^T \mathbf{Q} (\Phi(s)\mathbf{B})} \quad (3.143)$$

where $\mathbf{L}(s)$ is the loop gain and \mathbf{K} the optimal feedback gain (obtained through the algebraic Riccati equation):

$$\boxed{\mathbf{L}(s) = \mathbf{K}\Phi(s)\mathbf{B}} \quad (3.144)$$

The proof of the Kalman equality is provided hereafter. Consider the *algebraic Riccati equation* (3.8):

$$\mathbf{P}\mathbf{A} + \mathbf{A}^T\mathbf{P} - \mathbf{P}\mathbf{B}\mathbf{R}^{-1}\mathbf{B}^T\mathbf{P} + \mathbf{Q} = \mathbf{0} \quad (3.145)$$

Because $\mathbf{K} = \mathbf{R}^{-1}\mathbf{B}^T\mathbf{P}$, $\mathbf{P} = \mathbf{P}^T$ and $\mathbf{R} = \mathbf{R}^T$, the previous equation can be re-written as:

$$\mathbf{P}(s\mathbb{I} - \mathbf{A}) - (-s\mathbb{I} - \mathbf{A})^T\mathbf{P} + \mathbf{K}^T\mathbf{R}\mathbf{K} = \mathbf{Q} \quad (3.146)$$

Using the fact that $\Phi(s) = (s\mathbb{I} - \mathbf{A})^{-1}$ we get:

$$\mathbf{P}\Phi^{-1}(s) + (\Phi^{-1}(-s))^T\mathbf{P} + \mathbf{K}^T\mathbf{R}\mathbf{K} = \mathbf{Q} \quad (3.147)$$

Left multiplying by $\mathbf{B}^T\Phi^T(-s)$ and right multiplying by $\Phi(s)\mathbf{B}$ yields:

$$\begin{aligned} \mathbf{B}^T\Phi^T(-s)\mathbf{P}\mathbf{B} + \mathbf{B}^T\mathbf{P}\Phi(s)\mathbf{B} + \mathbf{B}^T\Phi^T(-s)\mathbf{K}^T\mathbf{R}\mathbf{K}\Phi(s)\mathbf{B} = \\ \mathbf{B}^T\Phi^T(-s)\mathbf{Q}\Phi(s)\mathbf{B} \end{aligned} \quad (3.148)$$

Adding \mathbf{R} to both sides of equation (3.148) as using the fact that $\mathbf{R}\mathbf{K} = \mathbf{B}^T\mathbf{P}$ we get:

$$\begin{aligned} \mathbf{R} + \mathbf{B}^T\Phi^T(-s)\mathbf{K}^T\mathbf{R} + \mathbf{R}\mathbf{K}\Phi(s)\mathbf{B} + \mathbf{B}^T\Phi^T(-s)\mathbf{K}^T\mathbf{R}\mathbf{K}\Phi(s)\mathbf{B} = \\ \mathbf{R} + \mathbf{B}^T\Phi^T(-s)\mathbf{Q}\Phi(s)\mathbf{B} \end{aligned} \quad (3.149)$$

The previous equation can be re-written as:

$$(\mathbb{I} + \mathbf{K}\Phi(-s)\mathbf{B})^T \mathbf{R} (\mathbb{I} + \mathbf{K}\Phi(s)\mathbf{B}) = \mathbf{R} + (\Phi(-s)\mathbf{B})^T \mathbf{Q} (\Phi(s)\mathbf{B}) \quad (3.150)$$

This completes the proof. \blacksquare

Let $\mathbf{R}^{-0.5}$ be the root-square of matrix \mathbf{R}^{-1} :

$$\mathbf{R}^{-1} = (\mathbf{R}^{-0.5})^T \mathbf{R}^{-0.5} \quad (3.151)$$

Multiplying Kalman equality (3.143) by $(\mathbf{R}^{-0.5})^T$ on the left side and by $\mathbf{R}^{-0.5}$ on the right side we get:

$$\begin{aligned} (\mathbf{R}^{-0.5})^T (\mathbb{I} + \mathbf{L}(-s))^T \mathbf{R} (\mathbb{I} + \mathbf{L}(s)) \mathbf{R}^{-0.5} \\ = (\mathbf{R}^{-0.5})^T \left(\mathbf{R} + (\Phi(-s)\mathbf{B})^T \mathbf{Q} (\Phi(s)\mathbf{B}) \right) \mathbf{R}^{-0.5} \end{aligned} \quad (3.152)$$

Matrix $\mathbf{R}^{0.5} = (\mathbf{R}^{0.5})^T$ is the root square of matrix \mathbf{R} . By getting the modal decomposition of matrix \mathbf{R} , that is $\mathbf{R} = \mathbf{V}\mathbf{D}\mathbf{V}^{-1}$ where \mathbf{V} is the matrix whose columns are the eigenvectors of \mathbf{R} and \mathbf{D} is the diagonal matrix whose diagonal elements are the corresponding positive eigenvalues, the square root $\mathbf{R}^{0.5}$ of \mathbf{R} is given by $\mathbf{R}^{0.5} = \mathbf{V}\mathbf{D}^{0.5}\mathbf{V}^{-1}$, where $\mathbf{D}^{0.5}$ is any diagonal matrix whose elements are the square root of the diagonal elements of \mathbf{D} . Thus we get:

$$\begin{aligned} \mathbf{R} = \mathbf{V}\mathbf{D}\mathbf{V}^{-1} &\Rightarrow \mathbf{R}^{-1} = \mathbf{V}\mathbf{D}^{-1}\mathbf{V}^{-1} \\ \Rightarrow (\mathbf{R}^{-0.5})^T \mathbf{R} \mathbf{R}^{-0.5} &= \mathbf{R}^{-0.5} \mathbf{R} \mathbf{R}^{-0.5} \\ &= (\mathbf{V}\mathbf{D}^{-0.5}\mathbf{V}^{-1}) (\mathbf{V}\mathbf{D}\mathbf{V}^{-1}) (\mathbf{V}\mathbf{D}^{-0.5}\mathbf{V}^{-1}) \\ &= \mathbf{V}\mathbf{D}^{-0.5} \mathbf{D} \mathbf{D}^{-0.5} \mathbf{V}^{-1} \\ &= \mathbb{I} \end{aligned} \quad (3.153)$$

Thus:

$$\begin{aligned} (\mathbf{R}^{-0.5})^T \left(\mathbf{R} + (\Phi(-s)\mathbf{B})^T \mathbf{Q} (\Phi(s)\mathbf{B}) \right) \mathbf{R}^{-0.5} \\ = \mathbb{I} + (\Phi(-s)\mathbf{B}\mathbf{R}^{-0.5})^T \mathbf{Q} (\Phi(s)\mathbf{B}\mathbf{R}^{-0.5}) \end{aligned} \quad (3.154)$$

On the other hand, we have:

$$\begin{aligned} (\mathbf{R}^{-0.5})^T (\mathbb{I} + \mathbf{L}(-s))^T \mathbf{R} (\mathbb{I} + \mathbf{L}(s)) \mathbf{R}^{-0.5} \\ = (\mathbf{R}^{-0.5} + \mathbf{L}(-s)\mathbf{R}^{-0.5})^T \mathbf{R} (\mathbf{R}^{-0.5} + \mathbf{L}(s)\mathbf{R}^{-0.5}) \\ = (\mathbf{R}^{-0.5} + \mathbf{L}(-s)\mathbf{R}^{-0.5})^T \mathbf{R}^{0.5} \mathbf{R}^{0.5} (\mathbf{R}^{-0.5} + \mathbf{L}(s)\mathbf{R}^{-0.5}) \\ = (\mathbb{I} + \mathbf{R}^{0.5}\mathbf{L}(-s)\mathbf{R}^{-0.5})^T (\mathbb{I} + \mathbf{R}^{0.5}\mathbf{L}(s)\mathbf{R}^{-0.5}) \end{aligned} \quad (3.155)$$

Finally, let $\mathbf{Q} := \mathbf{N}^T\mathbf{N}$. Then Kalman equality (3.143) can equivalently be written as follows:

$$\begin{aligned} (\mathbb{I} + \mathbf{R}^{0.5}\mathbf{L}(-s)\mathbf{R}^{-0.5})^T (\mathbb{I} + \mathbf{R}^{0.5}\mathbf{L}(s)\mathbf{R}^{-0.5}) \\ = \mathbb{I} + (\mathbf{N}\Phi(-s)\mathbf{B}\mathbf{R}^{-0.5})^T (\mathbf{N}\Phi(s)\mathbf{B}\mathbf{R}^{-0.5}) \end{aligned} \quad (3.156)$$

3.9.4 Robustness of Linear Quadratic Regulator

The robustness of the LQR design can be assessed through the Kalman equality (3.143). We will specialize Kalman equality to the specific case where the plant is a Single Input - Single Output (SISO) system. Then $\mathbf{K}\Phi(s)\mathbf{B}$ and \mathbf{R} are scalars. Setting $\mathbf{Q} = \mathbf{N}^T\mathbf{N}$, and using the fact that $\mathbf{N}\Phi(s)\mathbf{B}$ is scalar for SISO plants, Kalman equality (3.143) reduces as follows:

$$\mathbf{Q} = \mathbf{N}^T\mathbf{N} \Rightarrow (1 + \mathbf{L}(-s))(1 + \mathbf{L}(s)) = 1 + \frac{1}{\mathbf{R}} (\mathbf{N}\Phi(-s)\mathbf{B})(\mathbf{N}\Phi(s)\mathbf{B}) \quad (3.157)$$

Transfer function $\mathbf{L}(s)$ is the loop gain, which is scalar for SISO plants:

$$\mathbf{L}(s) = \mathbf{K}\Phi(s)\mathbf{B} \quad (3.158)$$

Substituting $s = j\omega$ yields:

$$\|1 + \mathbf{L}(j\omega)\|^2 = 1 + \frac{1}{\mathbf{R}} \|\mathbf{N}\Phi(j\omega)\mathbf{B}\|^2 \quad (3.159)$$

Therefore:

$$\|1 + \mathbf{L}(j\omega)\| \geq 1 \quad \forall \omega \in \mathbb{R} \quad (3.160)$$

For SISO plants, the sensitivity function $\mathbf{S}(s)$ and the complementary sensitivity function $\mathbf{T}(s)$ are defined as follows:

$$\begin{cases} \mathbf{S}(s) = \frac{1}{1+\mathbf{L}(s)} \\ \mathbf{T}(s) = 1 - \mathbf{S}(s) = \frac{\mathbf{L}(s)}{1+\mathbf{L}(s)} \end{cases} \quad (3.161)$$

Substituting $s = j\omega$, Kalman's inequality guarantees that:

$$\begin{cases} \|\mathbf{S}(j\omega)\| \leq 1 \\ \|\mathbf{T}(j\omega)\| \leq 2 \end{cases} \quad (3.162)$$

Those inequalities are represented in Figure 3.4.

We recall that:

- A small sensitivity function is desirable for good disturbance rejection. Generally, this is especially important at low frequencies.
- A complementary sensitivity function close to one is desirable for good reference tracking. Generally, this is especially important at low frequencies.
- A small complementary sensitivity function is desirable for good noise rejection. Generally, this is especially important at high frequencies.

Furthermore, let's introduce the real part $X(\omega)$ and the imaginary part $Y(\omega)$ of $\mathbf{L}(j\omega)$:

$$\mathbf{L}(j\omega) = X(\omega) + jY(\omega) \quad (3.163)$$

Then $\|1 + \mathbf{L}(j\omega)\|^2$ reads as follows:

$$\|1 + \mathbf{L}(j\omega)\|^2 = \|1 + X(\omega) + jY(\omega)\|^2 = (1 + X(\omega))^2 + Y(\omega)^2 \quad (3.164)$$

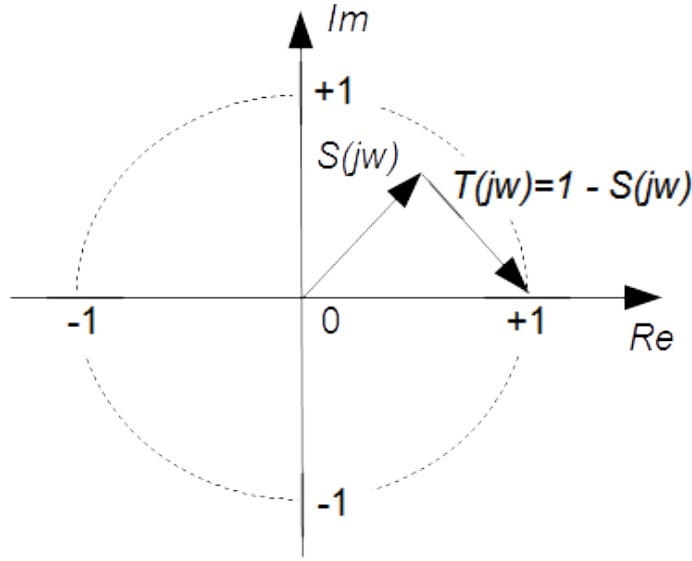

Figure 3.4: Upper bounds of sensitivity function $\mathbf{S}(s)$ and complementary sensitivity function $\mathbf{T}(s)$ through LQR design

Consequently inequality (3.160) reads as follows:

$$\begin{aligned}
 \|1 + \mathbf{L}(j\omega)\| &\geq 1 \\
 \Leftrightarrow \|1 + \mathbf{L}(j\omega)\|^2 &\geq 1 \\
 \Leftrightarrow (1 + X(\omega))^2 + Y(\omega)^2 &\geq 1
 \end{aligned} \tag{3.165}$$

As a consequence, the Nyquist plot of $\mathbf{L}(j\omega)$ will be outside the circle of unit radius centered at $(-1, 0)$. Thus applying the generalized (MIMO) Nyquist stability criterion and knowing that the LQR design always leads to a stable closed-loop plant, the implications of Kalman inequality are the following:

- If the open-loop system has no unstable pole, then the Nyquist plot of $\mathbf{L}(j\omega)$ does not encircle the critical point $(-1, 0)$. This corresponds to a positive gain margin of $+\infty$ as depicted as depicted in Figure 3.5.
- On the other hand if $\Phi(s)$ has unstable poles, the Nyquist plot of $\mathbf{L}(j\omega)$ encircles the critical point $(-1, 0)$ a number on times which corresponds to the number of unstable open-loop poles. This corresponds to a negative gain margin which is always lower or equal to $20 \log_{10}(0.5) = -6 \text{ dB}$ as depicted in Figure 3.6.

In both situations, if the process' phase increases by 60 degrees its Nyquist plots rotates by 60 degrees but the number of encirclements still does not change. Thus the LQR design always leads to a phase margin which is always greater or equal to 60 degrees.

Last but not least, it can be seen in Figure 3.5 and Figure 3.6 that at high-frequency the loop gain $\mathbf{L}(j\omega)$ can have at most -90 degrees phase for high-frequencies and therefore the *roll-off* rate is at most -20 dB/decade .

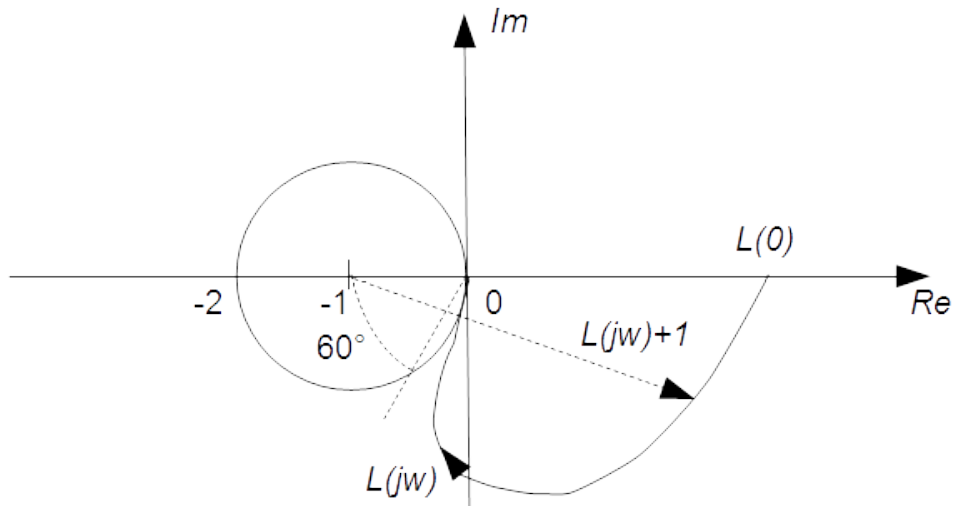

Figure 3.5: Nyquist plot of $\mathbf{L}(s)$: example where the open-loop system has no unstable pole

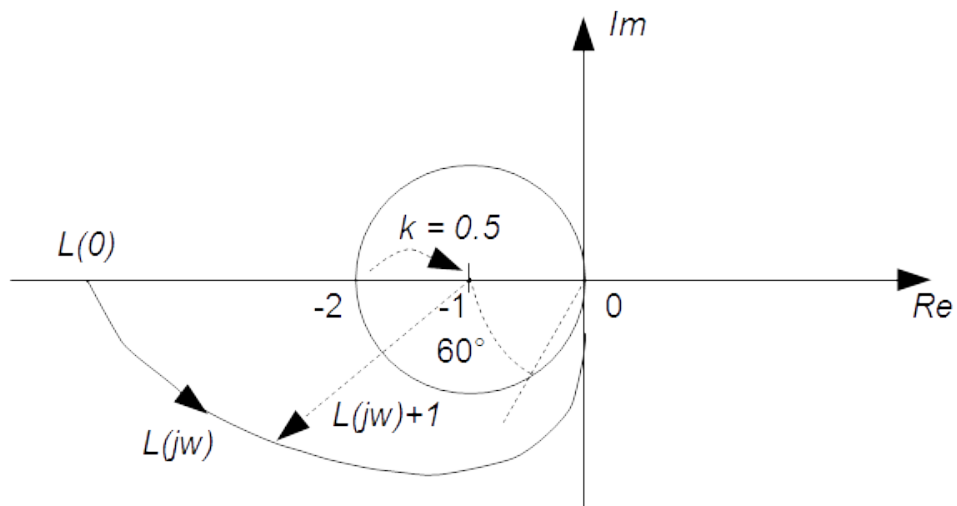

Figure 3.6: Nyquist plot of $\mathbf{L}(s)$: example where the open-loop system has unstable poles

Unfortunately those nice properties are lost as soon as the performance index $J(\underline{u}(t))$ contains state / control cross-terms ⁸:

$$J(\underline{u}(t)) = \frac{1}{2} \int_0^{t_f} \underline{x}^T(t) \mathbf{Q} \underline{x}(t) + \underline{u}^T(t) \mathbf{R} \underline{u}(t) + 2 \underline{x}^T(t) \mathbf{S} \underline{u}(t) dt \quad (3.166)$$

This is especially the case for LQG (Linear Quadratic Gaussian) regulator where the plant dynamics as well as the output measurement are subject to stochastic disturbances and where a state estimator has to be used.

⁸Doyle J.C., Guaranteed margins for LQG regulators, IEEE Transactions on Automatic Control, Volume: 23, Issue: 4, Aug 1978

Chapter 4

Design methods

4.1 Symmetric Root Locus

4.1.1 Characteristics polynomials

Let's consider the following state space realization $(\mathbf{A}, \mathbf{B}, \mathbf{N})$:

$$\begin{cases} \dot{\underline{x}}(t) = \mathbf{A}\underline{x}(t) + \mathbf{B}u(t) \\ \underline{z}(t) = \mathbf{N}\underline{x}(t) \end{cases} \quad (4.1)$$

We will assume that $(\mathbf{A}, \mathbf{B}, \mathbf{N})$ is minimal, or equivalently that (\mathbf{A}, \mathbf{B}) is controllable and (\mathbf{A}, \mathbf{N}) is observable, or equivalently that the following loop gain (or open-loop) transfer function is irreducible:

$$G(s) = \mathbf{N}(s\mathbb{I} - \mathbf{A})^{-1}\mathbf{B} = \frac{\mathbf{N} \operatorname{adj}(s\mathbb{I} - \mathbf{A})\mathbf{B}}{\det(s\mathbb{I} - \mathbf{A})} = \frac{N(s)}{D(s)} \quad (4.2)$$

The polynomial $D(s) = \det(s\mathbb{I} - \mathbf{A})$ is the loop gain characteristics polynomial, which is assumed to be of degree n , and polynomial matrix $N(s)$ is the numerator of $\mathbf{N}(s\mathbb{I} - \mathbf{A})^{-1}\mathbf{B}$. From the fact that the numerator of $G(s)$ involves $\operatorname{adj}(s\mathbb{I} - \mathbf{A})$ it is clear that the degree of its numerator $N(s)$, which will be denoted m , is strictly lower than the degree of its denominator $D(s)$, which will be denoted n :

$$\operatorname{deg}(N(s)) = m < \operatorname{deg}(D(s)) = n \quad (4.3)$$

It can be shown that for single-input single-output (SISO) systems we have the following relation where $N(s)$ is the polynomial (not matrix) numerator of the transfer function:

$$G(s) = \mathbf{N}(s\mathbb{I} - \mathbf{A})^{-1}\mathbf{B} = \frac{\det\left(\begin{bmatrix} s\mathbb{I} - \mathbf{A} & -\mathbf{B} \\ \mathbf{N} & 0 \end{bmatrix}\right)}{\det(s\mathbb{I} - \mathbf{A})} = \frac{N(s)}{D(s)} \quad (4.4)$$

Now let's assume that the system is closed thanks to the following output (not state !) feedback control $u(t)$:

$$u(t) = -k_p \mathbf{K}_o \underline{z}(t) + \mathbf{F}r(t) \quad (4.5)$$

Where:

- k_p is a scaling factor
- \mathbf{K}_o is the output (not state !) feedback matrix gain
- \mathbf{F} is the pre-filter gain

Then the state matrix of the closed-loop system reads $\mathbf{A} - k_p \mathbf{B} \mathbf{K}_o \mathbf{N}$ and the polynomial $\det(s\mathbb{I} - \mathbf{A} + k_p \mathbf{B} \mathbf{K}_o \mathbf{N})$ is the closed-loop characteristics polynomial.

4.1.2 Root Locus reminder

The root locus technique¹ has been developed in 1948 by Walter R. Evans (1920-1999). This is a graphical method for sketching in the s -plane the locus of roots of the following polynomial when parameter k_p varies to 0 to infinity:

$$\det(s\mathbb{I} - \mathbf{A} + k_p \mathbf{B} \mathbf{K}_o \mathbf{N}) = D(s) + k_p N(s) \quad (4.6)$$

Usually polynomial $D(s) + k_p N(s)$ represents the denominator of a closed-loop transfer function. Polynomial $D(s) + k_p N(s)$ represents here the denominator of the closed-loop transfer function when control $u(t)$ reads:

$$u(t) = -k_p \mathbf{K}_o y(t) + \mathbf{F}r(t) \quad (4.7)$$

It is worth noticing that the roots of $D(s) + k_p N(s)$ are also the roots of $1 + k_p \frac{N(s)}{D(s)}$:

$$D(s) + k_p N(s) = 0 \Leftrightarrow 1 + k_p \frac{N(s)}{D(s)} = 0 \Leftrightarrow L(s) := k_p F(s) = -1 \quad (4.8)$$

Without loss of generality let's define transfer function $F(s)$ as follows:

$$F(s) = \frac{N(s)}{D(s)} = a \frac{\prod_{j=1}^{m \leq n} (s - z_j)}{\prod_{i=1}^n (s - p_i)} \quad (4.9)$$

Transfer function $L(s) = k_p F(s)$ is called the loop transfer function. In the SISO case the numerator of the loop transfer function $L(s)$ is scalar as well as its denominator.

Equation $L(s) = -1$ can be equivalently split into two equations:

$$\begin{cases} |L(s)| = 1 \\ \arg(L(s)) = (2k + 1)\pi, \quad k = 0, \pm 1, \dots \end{cases} \quad (4.10)$$

The magnitude condition can always be satisfied by a suitable choice of k_p . On the other hand the phase condition does not depend on the value of k_p but only on the sign of k_p . Thus we have to find all the points in the s -plane that satisfy the phase condition. When scalar gain k_p varies from zero to infinity (i.e. k_p is positive), the root locus technique is based on the following rules:

¹Walter R. Evans, Graphical Analysis of Control Systems, Transactions of the American Institute of Electrical Engineers, vol. 67, pp. 547 - 551, 1948

- The root locus is symmetrical with respect to the horizontal real axis (because roots are either real or complex conjugate);
- The number of branches is equal to the number of poles of the loop transfer function. Thus the root locus has n branches;
- The root locus starts at the n poles of the loop transfer function;
- The root locus ends at the zeros of the loop transfer function. Thus m branches of the root locus end on the m zeros of $F(s)$ and there are $(n-m)$ asymptotic branches;
- Assuming that coefficient a in $F(s)$ is positive, a point s^* on the real axis belongs to the root locus as soon as there is an odd number of poles and zeros on its right. Conversely assuming that coefficient a in $F(s)$ is negative, a point s^* on the real axis belongs to the root locus as soon as there is an even number of poles and zeros on its right. Be careful to take into account the multiplicity of poles and zeros in the counting process;
- The $(n-m)$ asymptotic branches of the root locus which diverge to ∞ are asymptotes.

- The angle δ_k of each asymptote with the real axis is defined by:

$$\delta_k = \frac{\pi + \arg(a) + 2k\pi}{n-m} \quad \forall k = 0, \dots, n-m-1 \quad (4.11)$$

- Denoting by p_i the n poles of the loop transfer function (that are the roots of $D(s)$) and by z_j the m zeros of the loop transfer function (that are the roots of $N(s)$), the asymptotes intersect the real axis at a point (called pivot or centroid) given by:

$$\sigma = \frac{\sum_{i=1}^n p_i - \sum_{j=1}^{m \leq n} z_j}{n-m} \quad (4.12)$$

- The breakaway / break-in points are located on the real axis and always have a vertical tangent. They are located at the roots s_b of the following equation as soon as there is an odd (if coefficient a in $F(s)$ is positive) or even (if coefficient a in $F(s)$ is negative) number of poles and zeros on its right (Be careful to take into account the multiplicity of poles and zeros in the counting process):

$$\begin{aligned} \frac{d}{ds} \left(\frac{1}{F(s)} \right)_{s=s_b} &= \frac{d}{ds} \left(\frac{D(s)}{N(s)} \right)_{s=s_b} = 0 \\ \Leftrightarrow D'(s_b)N(s_b) - D(s_b)N'(s_b) &= 0 \end{aligned} \quad (4.13)$$

Indeed from the fact that breakaway / break-in points have always a vertical tangent we can write:

$$1 + k_p F(s) = 1 + k_p \frac{N(s)}{D(s)} = 0 \Rightarrow \frac{dk_p}{dp} = - \frac{D'(s)N(s) - D(s)N'(s)}{N^2(s)} = 0 \quad (4.14)$$

From this relation we get (4.13).

- On the imaginary axis we have $s = j\omega$. Thus the value of the (positive) critical gain beyond which the closed-loop system becomes unstable is the value of k_p ($k_p \geq 0$) such that the root locus of $F(s)$ crosses the imaginary axis. In that situation at least one pole of the closed-loop system is purely imaginary. As far as $D(s) + k_p N(s)$ represents the denominator of the closed-loop transfer function the critical gain can be obtained by replacing s by $j\omega$ and by solving:

$$1 + k_p F(j\omega) = 0 \Leftrightarrow D(j\omega) + k_p N(j\omega) = 0 \quad (4.15)$$

The previous equation is then split into its real and imaginary part and provides a system of 2 equations which lead to the value of the critical gain and the oscillation frequency at the critical gain. It is worth noticing that the Routh criterion can be used for the same purpose.

- Note that if the degree of polynomial $D(s)$ is greater than or equal to the degree of polynomial $N(s)$ plus 2, meaning that the relative degree of transfer function $F(s)$ is greater than or equal to 2 ($n - m \geq 2$), then the sum of the poles of the feedback system is independent of the value of parameter k_p , and therefore is equal to the sum of the poles of the open loop system when $k_p = 0$. This property is known as the *centroid theorem*. To get this result, we have simply to expand $D(s) + k_p N(s)$ taking into account $n - m \geq 2$:

$$\begin{aligned} F(s) = \frac{N(s)}{D(s)} &= a \frac{\prod_{j=1}^{m \leq n-2} (s - z_j)}{\prod_{i=1}^n (s - p_i)} \\ \Rightarrow D(s) + k_p N(s) &= \prod_{i=1}^n (s - p_i) + k_p a \prod_{j=1}^{m \leq n-2} (s - z_j) \\ &= s^n - (r_1 + r_2 + \dots + r_n) s^{n-1} + \dots \end{aligned} \quad (4.16)$$

Assuming that $n - m \geq 2$, the coefficient of the term s^{n-1} in polynomial $D(s) + k_p N(s)$ does not depend on parameter k_p . Because this coefficient is obtained has the opposite of the sum $r_1 + r_2 + \dots + r_n$ of the roots of polynomial $D(s) + k_p N(s)$, we conclude the sum of the poles of the feedback system is independent of the value of parameter k_p .

4.1.3 Chang-Letov design procedure

The purpose of this section is to have some insight on how to drive the modes of the closed-loop plant thanks to the LQR design applied to SISO plants. More precisely, we focus on single-input plants for which the cost to be minimized is defined as in (3.3):

$$J(u(t)) = \frac{1}{2} \int_0^\infty (\underline{x}^T(t) \mathbf{Q} \underline{x}(t) + u^T(t) \mathbf{R} u(t)) dt \quad (4.17)$$

Nevertheless, weight matrix \mathbf{Q} is here defined as follows, where matrix \mathbf{N} is a design matrix:

$$\mathbf{Q} = \mathbf{N}^T \mathbf{N} \quad (4.18)$$

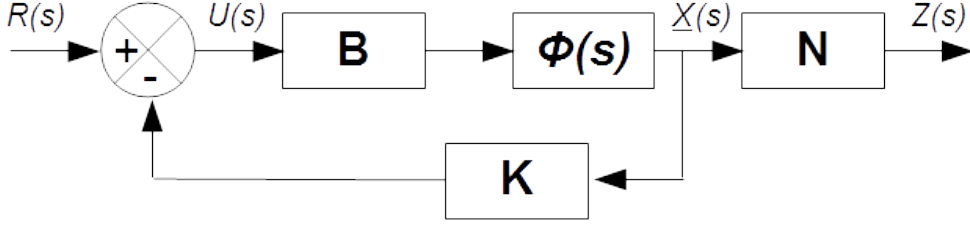
Figure 4.1: Full-state feedback control with *fictitious* output z

Let $\underline{z}(t) := \mathbf{N}\underline{x}(t)$ be the *controlled* output: this is a *fictitious* output which represents the output of interest for the design. The *controlled* output $\underline{z}(t)$ is expressed as a linear function of the state vector $\underline{x}(t)$ as:

$$\underline{z}(t) := \mathbf{N}\underline{x}(t) \quad (4.19)$$

Thus the cost to be minimized can be rewritten as follows:

$$\begin{aligned} J(u(t)) &= \frac{1}{2} \int_0^\infty (\underline{x}^T(t) \mathbf{N}^T \mathbf{N} \underline{x}(t) + \mathbf{R}u^2(t)) dt \\ &= \frac{1}{2} \int_0^\infty (\underline{z}^T(t) \underline{z}(t) + \mathbf{R}u^2(t)) dt \end{aligned} \quad (4.20)$$

Furthermore the cost to be minimized is now *constrained* by the dynamics of the system with the following state space representation:

$$\begin{cases} \dot{\underline{x}}(t) = \mathbf{A}\underline{x}(t) + \mathbf{B}u(t) \\ \underline{z}(t) = \mathbf{N}\underline{x}(t) \end{cases} \quad (4.21)$$

From this state space representation we obtain the following open-loop transfer function which is written as the ratio between a numerator $N(s)$ and a denominator $D(s)$:

$$\mathbf{N}(s\mathbb{I} - \mathbf{A})^{-1} \mathbf{B} = \frac{N(s)}{D(s)} \quad (4.22)$$

We recall that the cost (4.20) is minimized by choosing the following control law, where \mathbf{P} is the solution of the algebraic Riccati equation:

$$\begin{cases} u(t) = -\mathbf{K}\underline{x}(t) \\ \mathbf{K} = \mathbf{R}^{-1} \mathbf{B}^T \mathbf{P} \end{cases} \quad (4.23)$$

This leads to a full-state feedback control with *fictitious* output z which is represented in Figure 4.1 where $\Phi(s) = (s\mathbb{I} - \mathbf{A})^{-1}$.

Let $D(s)$ be the open-loop characteristics polynomial and $\beta(s)$ be the closed-loop characteristic polynomial:

$$\begin{cases} D(s) = \det(s\mathbb{I} - \mathbf{A}) \\ \beta(s) = \det(s\mathbb{I} - \mathbf{A} + \mathbf{B}\mathbf{K}) \end{cases} \quad (4.24)$$

In the single control case which is under consideration, it can be shown (see section 4.1.4) that the characteristic polynomial of the closed-loop system is

linked with the numerator and the denominator of the loop transfer function as follows:

$$\beta(s)\beta(-s) = D(s)D(-s) + \frac{1}{\mathbf{R}}N(s)N(-s) \quad (4.25)$$

This relation can be associated with the root locus of $G(s)G(-s) = \frac{N(s)N(-s)}{D(s)D(-s)}$ where fictitious gain $k_p = \frac{1}{\mathbf{R}}$ varies from 0 to ∞ . This leads to the so-called Chang-Letov design procedure, which enables to find the closed-loop poles based on the open-loop poles and zeros of $G(s)G(-s)$. The difference with the root locus of $G(s)$ is that both the open-loop poles and zeros and their reflections about the imaginary axis have to be taken into account (this is due to the multiplication by $G(-s)$). The actual closed-loop poles are those located in the left half plane with negative real part; indeed optimal control leads always to a stabilizing gain. It is worth noticing that matrix \mathbf{N} is actually a design parameter which is used to shape the root locus.

4.1.4 Proof of the symmetric root locus result

The proof of (4.25) can be done as follows: taking the determinant of the Kalman equality (3.143) and having in mind that $\det(\mathbf{M}^T) = \det(\mathbf{M})$ and that for SISO systems \mathbf{R} is scalar yields:

$$\begin{aligned} \det\left(\left(\mathbb{I} + \mathbf{K}\Phi(-s)\mathbf{B}\right)^T \mathbf{R} \left(\mathbb{I} + \mathbf{K}\Phi(s)\mathbf{B}\right)\right) &= \det\left(\mathbf{R} + (\Phi(-s)\mathbf{B})^T \mathbf{Q} (\Phi(s)\mathbf{B})\right) \\ \Leftrightarrow \det\left(\left(\mathbb{I} + \mathbf{K}\Phi(-s)\mathbf{B}\right)^T \left(\mathbb{I} + \mathbf{K}\Phi(s)\mathbf{B}\right)\right) &= \det\left(\mathbb{I} + \frac{(\Phi(-s)\mathbf{B})^T \mathbf{Q} (\Phi(s)\mathbf{B})}{\mathbf{R}}\right) \\ \Leftrightarrow \det\left(\left(\mathbb{I} + \mathbf{K}\Phi(-s)\mathbf{B}\right)^T\right) \det\left(\mathbb{I} + \mathbf{K}\Phi(s)\mathbf{B}\right) &= \det\left(\mathbb{I} + \frac{(\Phi(-s)\mathbf{B})^T \mathbf{Q} (\Phi(s)\mathbf{B})}{\mathbf{R}}\right) \\ \Leftrightarrow \det\left(\mathbb{I} + \mathbf{K}\Phi(-s)\mathbf{B}\right) \det\left(\mathbb{I} + \mathbf{K}\Phi(s)\mathbf{B}\right) &= \det\left(\mathbb{I} + \frac{(\Phi(-s)\mathbf{B})^T \mathbf{Q} (\Phi(s)\mathbf{B})}{\mathbf{R}}\right) \end{aligned} \quad (4.26)$$

Where:

$$\Phi(s) = (s\mathbb{I} - \mathbf{A})^{-1} = \frac{\text{adj}(s\mathbb{I} - \mathbf{A})}{\det(s\mathbb{I} - \mathbf{A})} \quad (4.27)$$

Furthermore it has been seen in (3.138) that thanks to the Hsu-Chen theorem we have:

$$\det\left(\mathbb{I} + \mathbf{K}\Phi(s)\mathbf{B}\right) = \frac{\det(s\mathbb{I} - \mathbf{A} + \mathbf{BK})}{\det(s\mathbb{I} - \mathbf{A})} \quad (4.28)$$

Let $D(s)$ be the open-loop characteristics polynomial and $\beta(s)$ be the closed-loop characteristic polynomial:

$$\begin{cases} D(s) = \det(s\mathbb{I} - \mathbf{A}) \\ \beta(s) = \det(s\mathbb{I} - \mathbf{A} + \mathbf{BK}) \end{cases} \quad (4.29)$$

As a consequence, using (4.28) in the left part of (4.26) yields:

$$\frac{\beta(s)\beta(-s)}{D(s)D(-s)} = \det\left(\mathbb{I} + \frac{(\Phi(-s)\mathbf{B})^T \mathbf{Q} (\Phi(s)\mathbf{B})}{\mathbf{R}}\right) \quad (4.30)$$

In the single control case \mathbf{R} and \mathbb{I} are scalars ($\mathbb{I} = 1$). Using $\mathbf{Q} = \mathbf{N}^T \mathbf{N}$ (4.30) becomes:

$$\begin{aligned} \frac{\beta(s)\beta(-s)}{D(s)D(-s)} &= \det \left(1 + \frac{(\mathbf{N}\Phi(-s)\mathbf{B})^T (\mathbf{N}\Phi(s)\mathbf{B})}{\mathbf{R}} \right) \\ &= 1 + \frac{(\mathbf{N}\Phi(-s)\mathbf{B})^T (\mathbf{N}\Phi(s)\mathbf{B})}{\mathbf{R}} \end{aligned} \quad (4.31)$$

We recognize in $\mathbf{N}\Phi(s)\mathbf{B} = \mathbf{N}(s\mathbb{I} - \mathbf{A})^{-1}\mathbf{B}$ the open-loop transfer function $G(s)$ which is the ratio between numerator polynomial $N(s)$ and denominator polynomial $D(s)$:

$$G(s) = \mathbf{N}\Phi(s)\mathbf{B} = \mathbf{N}(s\mathbb{I} - \mathbf{A})^{-1}\mathbf{B} = \frac{N(s)}{D(s)} \quad (4.32)$$

Using (4.32) in (4.31) yields:

$$\begin{aligned} \frac{\beta(s)\beta(-s)}{D(s)D(-s)} &= 1 + \frac{1}{\mathbf{R}} \frac{N(s)N(-s)}{D(s)D(-s)} \\ \Leftrightarrow \beta(s)\beta(-s) &= D(s)D(-s) + \frac{1}{\mathbf{R}} N(s)N(-s) \end{aligned} \quad (4.33)$$

This completes the proof. ■

4.2 Asymptotic properties of LQR applied to SISO plants

We will see that Kalman equality allows for loop shaping through LQR design for SISO plants. Lectures from professor Faryar Jabbari (Henry Samueli School of Engineering, University of California) and professor Perry Y. Li (University of Minnesota) are the primary sources of this section.

We recall that $\Phi(s) = (s\mathbb{I} - \mathbf{A})^{-1}$ where $\dim(\mathbf{A}) = n \times n$, which is also the dimension of weight $\mathbf{Q} := \mathbf{N}^T \mathbf{N}$.

4.2.1 Closed-loop poles location

Relation (4.25) reads:

$$\beta(s)\beta(-s) = D(s)D(-s) + \frac{1}{\mathbf{R}} N(s)N(-s) \quad (4.34)$$

From (4.34) we can get the following results:

- When \mathbf{R} is large, i.e. $1/\mathbf{R}$ is small so that the control energy is weighted very heavily in the performance index, the roots of $\beta(s)$, that are the closed-loop poles, approach the stable open-loop poles or the negative of the unstable open-loop poles:

$$\beta(s)\beta(-s) \approx D(s)D(-s) \text{ as } \mathbf{R} \rightarrow \infty \quad (4.35)$$

- When \mathbf{R} is small (i.e. $\mathbf{R} \rightarrow 0$) then $1/\mathbf{R}$ is large and the control is cheap. Then the roots of $\beta(s)$, that are the closed-loop poles, approach the stable open-loop zeros or the negative of the non-minimum phase open-loop zeros:

$$\beta(s)\beta(-s) \approx \frac{1}{\mathbf{R}}N(s)N(-s) \text{ as } \mathbf{R} \rightarrow 0 \quad (4.36)$$

Equation (4.36) shows that any roots of $\beta(s)\beta(-s)$ that remains finite as $\mathbf{R} \rightarrow 0$ must tend toward the roots of $N(s)N(-s)$. But from (4.3) we know that the degree of $N(s)N(-s)$, say $2m$, is less than the degree of $\beta(s)\beta(-s)$, which is $2n$. Therefore m roots of $\beta(s)$ are the roots of $N(s)N(-s)$ in the open left half plane (*stable* roots). The remaining $n - m$ roots of $\beta(s)$ asymptotically approach infinity in the left half plane. For very large s we can ignore all but the highest power of s in (4.34) so that the magnitude (or modulus) of the roots that tend toward infinity shall satisfy the following approximate relation:

$$(-1)^n s^{2(n-m)} \approx \frac{b_m^2}{\mathbf{R}}(-1)^m \quad (4.37)$$

where we denote:

$$\begin{cases} \beta(s) = \det(s\mathbb{I} - \mathbf{A} + \mathbf{BK}) = s^n + \beta_{n-1}s^{n-1} + \cdots + \beta_1s + \beta_0 \\ N(s) = b_m s^m + b_{m-1}s^{m-1} + \cdots + b_1s + b_0 \end{cases} \quad (4.38)$$

The roots of $\beta(-s)$ are the reflection across the imaginary of the roots of $\beta(s)$. Now express s in the exponential form:

$$s = r e^{j\theta} \quad (4.39)$$

We get from (4.37):

$$(-1)^n r^{2n} e^{j2n\theta} \approx \frac{b_m^2}{\mathbf{R}}(-1)^m r^{2m} e^{j2m\theta} \Rightarrow r^{2(n-m)} \approx \frac{b_m^2}{\mathbf{R}} \quad (4.40)$$

Therefore, the remaining $n - m$ zeros of $\beta(s)$ lie on a circle of radius r defined by:

$$r \approx \left(\frac{b_m}{\sqrt{\mathbf{R}}} \right)^{\frac{1}{n-m}} \quad (4.41)$$

The particular pattern to which the $2(n - m)$ solutions of (4.41) lie is known as the Butterworth configuration. The angle of the $2(n - m)$ branches which diverge to ∞ are obtained by adapting relation (4.11) to the case where transfer function reads $G(s)G(-s) = \frac{N(s)N(-s)}{D(s)D(-s)}$.

4.2.2 Shape of the magnitude of the loop gain

We recall that the loop gain $\mathbf{L}(s)$ is defined as follows:

$$\mathbf{L}(s) := \mathbf{K}\Phi(s)\mathbf{B} \quad (4.42)$$

When $\mathbf{Q} = \mathbf{N}^T\mathbf{N}$, and assuming a SISO plant, Kalman equality (3.143) becomes:

$$\begin{aligned} (1 + \mathbf{L}(-s))^T (1 + \mathbf{L}(s)) &= 1 + \frac{1}{\mathbf{R}} (\Phi(-s)\mathbf{B})^T \mathbf{N}^T \mathbf{N} (\Phi(s)\mathbf{B}) \\ &= 1 + \frac{1}{\mathbf{R}} (\mathbf{N}\Phi(-s)\mathbf{B})^T (\mathbf{N}(\Phi(s)\mathbf{B})) \end{aligned} \quad (4.43)$$

Denoting by $\lambda(\mathbf{X}(j\omega))$ the eigenvalues of matrix $\mathbf{X}(j\omega)$ and by $\sigma(\mathbf{X}(j\omega))$ its singular values (that are the root square of the strictly positive eigenvalues of either $\mathbf{X}^T(-j\omega)\mathbf{X}(j\omega)$ or $\mathbf{X}(j\omega)\mathbf{X}^T(-j\omega)$), the preceding equality implies:

$$\begin{aligned}\lambda\left(\left(1 + \mathbf{L}(-j\omega)\right)^T \left(1 + \mathbf{L}(j\omega)\right)\right) &= 1 + \frac{1}{\mathbf{R}} \lambda\left(\left(\mathbf{N}\Phi(-j\omega)\mathbf{B}\right)^T \left(\mathbf{N}\Phi(j\omega)\mathbf{B}\right)\right) \\ \Leftrightarrow \sigma\left(1 + \mathbf{L}(j\omega)\right) &= \sqrt{1 + \frac{1}{\mathbf{R}} \sigma^2\left(\mathbf{N}\Phi(j\omega)\mathbf{B}\right)}\end{aligned}\quad (4.44)$$

For the range of frequencies for which $\sigma(\mathbf{N}\Phi(j\omega)\mathbf{B}) \gg 1$ (typically low frequencies) equation (4.44) shows that:

$$\sigma(\mathbf{L}(j\omega)) \approx \frac{1}{\sqrt{\mathbf{R}}} \sigma(\mathbf{N}\Phi(j\omega)\mathbf{B}) \quad (4.45)$$

For SISO system matrices \mathbf{N} and \mathbf{K} have the same dimension. Denoting by $|\mathbf{K}|$ the absolute value of each element of \mathbf{K} , and using the fact that $\mathbf{L}(s) := \mathbf{K}\Phi(s)\mathbf{B}$, we get from the previous equation :

$$\sigma(\mathbf{L}(j\omega)) \approx \frac{1}{\sqrt{\mathbf{R}}} \sigma(\mathbf{N}\Phi(j\omega)\mathbf{B}) \Rightarrow |\mathbf{K}| \approx \frac{|\mathbf{N}|}{\sqrt{\mathbf{R}}} \text{ where } \mathbf{Q} = \mathbf{N}^T \mathbf{N} \quad (4.46)$$

Assuming that $\underline{z} = \mathbf{N}\underline{x}$, then $\mathbf{N}\Phi(s)\mathbf{B}$ represents the transfer function from the control signal $u(t)$ to the controlled output $\underline{z}(t)$. As a consequence:

- The shape of the magnitude of the loop gain $\mathbf{L}(s)$ is determined by the magnitude of the transfer function from the control input $u(t)$ to the controlled output $\underline{z}(t)$;
- Parameter $\sqrt{\mathbf{R}}$, that is weight \mathbf{R} , moves the magnitude Bode plot up and down.

Note that although the magnitude of $\mathbf{L}(s)$ mimics the magnitude of $\mathbf{N}\Phi(s)\mathbf{B}$, the phase of the loop gain $\mathbf{L}(s)$ always leads to a stable closed-loop with an appropriate phase margin. At high-frequency, it has been seen in Figure 3.5 and Figure 3.6 that the loop gain $\mathbf{L}(j\omega)$ can have at most -90 degrees phase for high-frequencies and therefore the *roll-off* rate is at most -20 dB/decade. In practice, this means that for $\omega \gg 1$, and for some constant a , we have the following approximation (remind that $\Phi(s) = (s\mathbb{I} - \mathbf{A})^{-1} = \frac{\text{adj}(s\mathbb{I} - \mathbf{A})}{\det(s\mathbb{I} - \mathbf{A})}$ so that the degree of the denominator of $\mathbf{L}(s)$ is n and the degree of its numerator is at most $n - 1$):

$$|\mathbf{L}(j\omega)| \approx \frac{a}{\omega\sqrt{\mathbf{R}}} \text{ where } \frac{a}{\sqrt{\mathbf{R}}} = \lim_{s \rightarrow \infty} s |\mathbf{L}(s)| \approx \lim_{s \rightarrow \infty} s \frac{1}{\sqrt{\mathbf{R}}} |\mathbf{N}\Phi(s)\mathbf{B}| \quad (4.47)$$

Thus:

$$a = \lim_{s \rightarrow \infty} s |\mathbf{N}\Phi(s)\mathbf{B}| \quad (4.48)$$

Therefore the cross-over frequency ω_c is approximately given by:

$$|\mathbf{L}(j\omega_c)| = 1 \approx \frac{a}{\omega_c\sqrt{\mathbf{R}}} \Rightarrow \omega_c \approx \frac{a}{\sqrt{\mathbf{R}}} \quad (4.49)$$

Consequently:

- LQR controllers always exhibit a high-frequency magnitude decay of -20 dB/decade. The (slow) -20 dB/decade magnitude decrease is the main shortcoming of state-feedback LQR controllers because it may not be sufficient to clear high-frequency upper bounds on the loop gain needed to reject disturbances and/or for robustness with respect to process uncertainty.
- The cross-over frequency is proportional to $1/\sqrt{\mathbf{R}}$ and generally small values for \mathbf{R} result in faster step responses.

4.2.3 Weighting matrices selection

The preceding results motivates the following design rule extended to the case of multiple input multiple output systems:

- Modal point of view: assuming that all states are available for control, choose \mathbf{N} (remind that $\mathbf{Q} = \mathbf{N}^T \mathbf{N} \Rightarrow \mathbf{Q}^{0.5} = \mathbf{N}$) such that $n - 1$ zeros of $\mathbf{N}\Phi(s)\mathbf{B}$ are at the desired pole location. Then use cheap control $\sqrt{\mathbf{R}} \rightarrow 0$ to design LQ system so that $n - 1$ poles of the closed-loop system approach these desired locations. It is worth noticing that for SISO plants the roots of $\mathbf{N}\Phi(s)\mathbf{B}$ are also the roots of:

$$\det \left(\begin{bmatrix} s\mathbb{I} - \mathbf{A} & -\mathbf{B} \\ \mathbf{N} & 0 \end{bmatrix} \right) = 0 \quad (4.50)$$

- Frequency point of view: alternatively we have seen that at low frequencies $|\mathbf{K}| \approx \frac{|\mathbf{N}|}{\sqrt{\mathbf{R}}}$ so that the loop gain is approximately $|\mathbf{L}(s)| \approx \frac{1}{\sqrt{\mathbf{R}}} |\mathbf{N}\Phi(s)\mathbf{B}|$. So the shape of the magnitude of the loop gain $\mathbf{L}(s)$ is determined by the magnitude of $\mathbf{N}\Phi(s)\mathbf{B}$, that is the transfer function from the control input $u(t)$ to the controlled output $z(t)$. In addition, we have seen that at high frequency $|\mathbf{N}\Phi(j\omega)\mathbf{B}| \approx \frac{a}{\omega\sqrt{\mathbf{R}}}$, where $a = \lim_{s \rightarrow \infty} s|\mathbf{N}\Phi(s)\mathbf{B}|$ is some constant. So we can choose $\sqrt{\mathbf{R}}$ to pick the bandwidth ω_c which is where $|\mathbf{L}(j\omega)| = 1$. Thus choose $\sqrt{\mathbf{R}} \approx \frac{a}{\omega_c}$ where ω_c is the desired bandwidth.

Thus contrary to the Chang-Letov design procedure for Single-Input Single-Output (SISO) systems where scalar \mathbf{R} was the design parameter the following design rules for Multi Input Multi Output (MIMO) systems use matrix \mathbf{Q} as the design parameter. We may also use the fact that if λ_i is a stable eigenvalue (i.e. eigenvalue in the open left half plane) of the Hamiltonian matrix $\mathbf{H} = \begin{bmatrix} \mathbf{A} & -\mathbf{B}\mathbf{R}^{-1}\mathbf{B}^T \\ -\mathbf{Q} & -\mathbf{A}^T \end{bmatrix}$ with eigenvector $\begin{bmatrix} \mathbf{X}_{1i} \\ \mathbf{X}_{2i} \end{bmatrix}$ then λ_i is also an eigenvalue of $\mathbf{A} - \mathbf{B}\mathbf{K}$ with eigenvector \mathbf{X}_{1i} . Therefore in the single input case we can use this result by finding the eigenvalues of \mathbf{H} and then realizing that the stable eigenvalues are the poles of the optimal closed-loop plant.

Alternatively, a simpler choice for matrices \mathbf{Q} and \mathbf{R} is given by the Bryson's rule who proposed to take \mathbf{Q} and \mathbf{R} as diagonal matrices such that:

$$\begin{cases} q_{ii} = \frac{1}{\max. \text{ acceptable value of } z_i^2} \\ r_{jj} = \frac{1}{\max. \text{ acceptable value of } u_j^2} \end{cases} \quad (4.51)$$

Diagonal matrices \mathbf{Q} and \mathbf{R} are associated to the following performance index where ρ is a free parameter to be set by the designer:

$$J(u(t)) = \frac{1}{2} \int_0^\infty \left(\sum_i q_{ii} z_i^2(t) + \rho^2 \sum_i r_{jj} u_j^2(t) \right) dt \quad (4.52)$$

If after simulation $|z_i(t)|$ is too large then increase q_{ii} ; similarly if after simulation $|u_j(t)|$ is too large then increase r_{jj} .

4.2.4 Poles assignment in optimal regulator using root locus

Let λ_i be an eigenvalue of the open-loop state matrix \mathbf{A} corresponding to eigenvector \underline{v}_i . This open-loop eigenvalue will not be modified by state feedback gain \mathbf{K} by setting in (4.120) the $m \times 1$ vector \underline{p}_i to zero and the $n \times 1$ eigenvector \underline{v}_{K_i} to the open-loop eigenvector \underline{v}_i corresponding to eigenvalue λ_i :

$$\begin{cases} \mathbf{A}\underline{v}_i = \lambda_i \underline{v}_i \\ \mathbf{K} = [\cdots \underbrace{0_{m \times 1}}_{i^{\text{th}} \text{ column}} \cdots] [\cdots \underbrace{\underline{v}_i}_{i^{\text{th}} \text{ column}} \cdots]^{-1} \end{cases} \quad (4.53)$$

$$\Rightarrow (\mathbf{A} - \mathbf{BK}) \underline{v}_i = \lambda_i \underline{v}_i$$

Coming back to the general case, let $\underline{v}_1, \dots, \underline{v}_n$ be the eigenvectors of the open-loop state matrix \mathbf{A} . Matrix \mathbf{V} is defined as follows:

$$\mathbf{V} = [\underline{v}_1 \quad \cdots \quad \underline{v}_n] \quad (4.54)$$

Note that if λ_i and $\lambda_j := \bar{\lambda}_i$ are complex conjugate eigenvalues, then the corresponding eigenvectors \underline{v}_i and \underline{v}_j are also complex conjugate:

$$\lambda_j = \bar{\lambda}_i \Leftrightarrow \underline{v}_j = \bar{\underline{v}}_i \quad (4.55)$$

In order to get a real valued matrix \mathbf{V} , \underline{v}_i and \underline{v}_j shall be changed into the real part and imaginary part of \underline{v}_i , that is $Re(\underline{v}_i)$ and $Im(\underline{v}_i)$, respectively.

Let $\lambda_1, \dots, \lambda_r$ be the $r \leq n$ eigenvalues that are desired to be changed by state feedback gain \mathbf{K} and $\underline{v}_1, \dots, \underline{v}_r$ the corresponding eigenvectors of the state matrix \mathbf{A} . Similarly let $\lambda_{r+1}, \dots, \lambda_n$ be the $n-r$ eigenvalues that are desired to be kept invariant by state feedback gain \mathbf{K} and $\underline{v}_{r+1}, \dots, \underline{v}_n$ the corresponding eigenvectors of the state matrix \mathbf{A} . Assuming that matrix \mathbf{V} is invertible, matrix \mathbf{M} is defined and split as follows where \mathbf{M}_r is an $r \times n$ matrix and \mathbf{M}_{n-r} is an $(n-r) \times n$ matrix:

$$\mathbf{M} = \mathbf{V}^{-1} = [\underline{v}_1 \quad \cdots \quad \underline{v}_r \quad \underline{v}_{r+1} \quad \cdots \quad \underline{v}_n]^{-1} = \begin{bmatrix} \mathbf{M}_r \\ \mathbf{M}_{n-r} \end{bmatrix} \quad (4.56)$$

Shieh & al.⁷ have shown that, once weighting matrix $\mathbf{R} = \mathbf{R}^T > 0$ is set, the characteristic polynomial $\beta(s)$ of the closed-loop transfer function is

linked with the numerator and the denominator of the loop transfer function $\Phi(s)\mathbf{B} = (s\mathbb{I} - \mathbf{A})^{-1}\mathbf{B}$ as follows:

$$\begin{aligned}\Phi(s)\mathbf{B} &= (s\mathbb{I} - \mathbf{A})^{-1}\mathbf{B} = \frac{\text{adj}(s\mathbb{I} - \mathbf{A})\mathbf{B}}{\det(s\mathbb{I} - \mathbf{A})} := \frac{\mathbf{N}_{ol}(s)}{D(s)} \\ \Rightarrow \beta(s)\beta(-s) &= D(s)D(-s) + k_p \underline{N}_{rl}(s) (\underline{N}_{rl}(-s))^T\end{aligned}\quad (4.57)$$

where:

$$\begin{cases} \mathbf{N}_{ol}(s) = \text{adj}(s\mathbb{I} - \mathbf{A})\mathbf{B} \\ \underline{N}_{rl}(s) = \underline{q}_0^T \mathbf{M}_r \mathbf{N}_{ol}(s) (\mathbf{R}^{0.5})^{-1} \\ \underline{q}_0 \in \mathbb{R}^{r \times 1} \end{cases}\quad (4.58)$$

Matrix $\mathbf{R}^{0.5} = (\mathbf{R}^{0.5})^T$ is the root square of matrix \mathbf{R} . By getting the modal decomposition of matrix \mathbf{R} , that is $\mathbf{R} = \mathbf{V}\mathbf{D}\mathbf{V}^{-1}$ where \mathbf{V} is the matrix whose columns are the eigenvectors of \mathbf{R} and \mathbf{D} is the diagonal matrix whose diagonal elements are the corresponding positive eigenvalues, the square root $\mathbf{R}^{0.5}$ of \mathbf{R} is given by $\mathbf{R}^{0.5} = \mathbf{V}\mathbf{D}^{0.5}\mathbf{V}^{-1}$, where $\mathbf{D}^{0.5}$ is any diagonal matrix whose elements are the square root of the diagonal elements of \mathbf{D}^2 .

Relation (4.57) can be associated with root locus of the fictitious transfer function $G(s)G(-s) = \frac{N_{rl}^T(s)N_{rl}(-s)}{D(s)D(-s)}$ where fictitious gain k_p varies from 0 to ∞ . The arbitrary nonzero $r \times 1$ column vector \underline{q}_0 is used to shape the locus. It is worth noticing that $\mathbf{M}_r \mathbf{N}_{ol}(s)$ and $D(s)$ share $\lambda_{r+1}, \dots, \lambda_n$ as common roots, and thus pole / zero simplification within $G(s)$ and $G(-s)$ shall be done before drawing the root locus.

Once the positive scalar k_p has been selected on the root locus such that the r closed-loop eigenvalues $\lambda_{K1}, \dots, \lambda_{Kr}$ are appropriately placed (note that for $k_p = 0$, the corresponding branches start at $\lambda_1, \dots, \lambda_r$), the weighting matrix \mathbf{Q} has the following expression:

$$\mathbf{Q} = k_p \mathbf{M}_r^T \begin{pmatrix} \underline{q}_0 & \underline{q}_0^T \end{pmatrix} \mathbf{M}_r \quad (4.59)$$

The following relation also holds:

$$\mathbf{Q} \begin{bmatrix} v_{r+1} & \dots & v_n \end{bmatrix} = \mathbf{0} \quad (4.60)$$

The preceding results is a generalization of the Chang-Letov design procedure seen in section 4.1.3. This may be used as follows: first choose \mathbf{R} and set $\mathbf{Q} = \mathbf{0}$ to get the minimum energy optimal control law. Then identify the r closed-loop eigenvalues which do not meet design specifications. Finally compute \mathbf{Q} as previously seen such that all eigenvalues are appropriately placed.

4.3 Poles shifting in optimal regulator

4.3.1 Mirror property

The purpose of this section is to underline the relation between the weighting matrix \mathbf{Q} and the closed-loop eigenvalues of the optimal regulator.

²https://en.wikipedia.org/wiki/Square_root_of_a_matrix

We recall the expression of the $2n \times 2n$ Hamiltonian matrix \mathbf{H} :

$$\mathbf{H} = \begin{bmatrix} \mathbf{A} & -\mathbf{B}\mathbf{R}^{-1}\mathbf{B}^T \\ -\mathbf{Q} & -\mathbf{A}^T \end{bmatrix} \quad (4.61)$$

which corresponds to the following algebraic Riccati equation:

$$\mathbf{A}^T\mathbf{P} + \mathbf{P}\mathbf{A} - \mathbf{P}\mathbf{B}\mathbf{R}^{-1}\mathbf{B}^T\mathbf{P} + \mathbf{Q} = \mathbf{0} \quad (4.62)$$

The characteristic polynomial of matrix \mathbf{H} in (4.61) is given by³:

$$\det(s\mathbb{I} - \mathbf{H}) = \det(s\mathbb{I} - \mathbf{A}) \det(\mathbb{I} - \mathbf{Q}\mathbf{S}(s)) \det(s\mathbb{I} + \mathbf{A}^T) \quad (4.63)$$

Where the term $\mathbf{S}(s)$ is defined by:

$$\mathbf{S}(s) = (s\mathbb{I} - \mathbf{A})^{-1} \mathbf{B}\mathbf{R}^{-1}\mathbf{B}^T (s\mathbb{I} + \mathbf{A}^T)^{-1} \quad (4.64)$$

Setting $\mathbf{Q} = \mathbf{Q}^T = 2\alpha\mathbf{P}$, where $\alpha \geq 0$ is a design parameter, the algebraic Riccati equation reads:

$$\mathbf{Q} = \mathbf{Q}^T = 2\alpha\mathbf{P} \Rightarrow (\mathbf{A} + \alpha\mathbb{I})^T\mathbf{P} + \mathbf{P}(\mathbf{A} + \alpha\mathbb{I}) - \mathbf{P}\mathbf{B}\mathbf{R}^{-1}\mathbf{B}^T\mathbf{P} = \mathbf{0} \quad (4.65)$$

which corresponds to the following Hamiltonian matrix \mathbf{H} :

$$\mathbf{H} = \begin{bmatrix} \mathbf{A} + \alpha\mathbb{I} & -\mathbf{B}\mathbf{R}^{-1}\mathbf{B}^T \\ \mathbf{0} & -(\mathbf{A} + \alpha\mathbb{I})^T \end{bmatrix} \quad (4.66)$$

Let λ_i be the open-loop eigenvalues, that are the eigenvalues of matrix \mathbf{A} . As far as the eigenvalues of a matrix are the same than the eigenvalues of its transpose, we can see that the $2n$ eigenvalues of the preceding Hamiltonian matrix is the set $\{\lambda_i + \alpha\} \cup \{-(\lambda_i + \alpha)\}$, $i = 1, \dots, n$.

Because the eigenvalues λ_{α_i} of $\mathbf{A} + \alpha\mathbb{I} - \mathbf{B}\mathbf{K}$ are the n eigenvalues of the Hamiltonian matrix \mathbf{H} with negative real part, and denoting $Re(\lambda)$ the real part of λ , there are two possibilities:

$$\begin{cases} Re(\lambda_i + \alpha) = Re(\lambda_i) + \alpha \leq 0 \Rightarrow \lambda_{\alpha_i} = \lambda_i + \alpha \\ Re(-(\lambda_i + \alpha)) = -Re(\lambda_i) - \alpha < 0 \Rightarrow \lambda_{\alpha_i} = -\lambda_i - \alpha \end{cases} \quad (4.67)$$

Finally let λ_{Ki} be the closed-loop eigenvalues, that are the eigenvalues of matrix $\mathbf{A} - \mathbf{B}\mathbf{K}$. The eigenvalues of $\mathbf{A} - \mathbf{B}\mathbf{K}$ are obtained from the eigenvalues of $\mathbf{A} + \alpha\mathbb{I} - \mathbf{B}\mathbf{K}$ by subtracting α to λ_{α_i} . Thus from (4.67), and given a controllable pair (\mathbf{A}, \mathbf{B}) , a positive definite symmetric matrix \mathbf{R} and a positive real constant α , the algebraic Riccati equation (4.65) where $\mathbf{Q} = \mathbf{Q}^T = 2\alpha\mathbf{P}$ has a unique positive definite solution $\mathbf{P} = \mathbf{P}^T > 0$ such that λ_{Ki} have the following property:

$$\begin{cases} Re(\lambda_i) \leq -\alpha \Rightarrow \lambda_{Ki} = \lambda_i \\ Re(\lambda_i) > -\alpha \Rightarrow \lambda_{Ki} = -\lambda_i - 2\alpha \quad \forall i = 1, \dots, n \\ Im(\lambda_{Ki}) = Im(\lambda_i) \end{cases} \quad (4.68)$$

4.3.2 Reduced-order model

The preceding result can be used to recursively shift on the left all the real parts of the poles of a system to any positions while preserving their imaginary parts. Let $\mathbf{A} \in \mathbb{R}^{n \times n}$ be the state matrix of the system to be controlled and $\mathbf{B} \in \mathbb{R}^{n \times m}$ the input matrix. We assume that all the eigenvalues of \mathbf{A} are distinct and that (\mathbf{A}, \mathbf{B}) is controllable and that the symmetric positive definite weighting matrix \mathbf{R} for the control is given. The purpose of this section is to compute the state weighting matrix \mathbf{Q} which leads to the desired closed-loop eigenvalues by shifting recursively the actual eigenvalues of the state matrix. It is worth noticing that, through the shifting process, real eigenvalues remain real eigenvalues whereas complex conjugate eigenvalues remain complex conjugate eigenvalues.

The core idea of the method is to consider the transformation $\underline{z}_i = \mathbf{C}^T \underline{x}$ where \mathbf{C} is appropriately chosen. This leads to the following reduced order model where matrix \mathbf{A} corresponds to the diagonal (or Jordan) form of state matrix \mathbf{A} :

$$\underline{z}_i = \mathbf{C}^T \underline{x} \Rightarrow \dot{\underline{z}}_i = \mathbf{A} \underline{z}_i + \mathbf{G} \underline{u} \text{ where } \begin{cases} \mathbf{C}^T \mathbf{A} = \mathbf{A} \mathbf{C}^T \Leftrightarrow \mathbf{A}^T \mathbf{C} = \mathbf{C} \mathbf{A}^T \\ \mathbf{G} = \mathbf{C}^T \mathbf{B} \end{cases} \quad (4.72)$$

In this new basis the performance index turns to be:

$$J_i = \frac{1}{2} \int_0^\infty \left(\underline{z}_i^T \tilde{\mathbf{Q}}_i \underline{z}_i + \underline{u}^T \mathbf{R} \underline{u} \right) dt \text{ where } \mathbf{Q} = \mathbf{C} \tilde{\mathbf{Q}}_i \mathbf{C}^T \quad (4.73)$$

4.3.3 Shifting one real eigenvalue

Let λ_i be an eigenvalue of \mathbf{A} . We will first assume that λ_i is real. We wish to shift λ_i to λ_{Ki} .

Let \underline{v} be a *left* eigenvector of \mathbf{A} : $\underline{v}^T \mathbf{A} = \lambda_i \underline{v}^T$. In other words, \underline{v} is a (right) eigenvector of \mathbf{A}^T corresponding to λ_i : $\mathbf{A}^T \underline{v} = \lambda_i \underline{v}$. Then we define \underline{z}_i as follows:

$$\underline{z}_i := \mathbf{C}^T \underline{x} \text{ where } \mathbf{C} = \underline{v} \quad (4.74)$$

Using the fact that \underline{v} is a (right) eigenvector of \mathbf{A}^T ($\underline{z}_i = \underline{v}^T \underline{x}$), we can write:

$$\begin{aligned} \dot{\underline{z}}_i &= \underline{v}^T \mathbf{A} \underline{x} + \underline{v}^T \mathbf{B} \underline{u} \\ &= \underline{v}^T \lambda_i \underline{x} + \underline{v}^T \mathbf{B} \underline{u} \\ &= \lambda_i \underline{v}^T \underline{x} + \underline{v}^T \mathbf{B} \underline{u} \\ &= \lambda_i \underline{z}_i + \underline{v}^T \mathbf{B} \underline{u} \\ &= \lambda_i \underline{z}_i + \mathbf{G} \underline{u} \text{ where } \mathbf{G} := \underline{v}^T \mathbf{B} = \mathbf{C}^T \mathbf{B} \end{aligned} \quad (4.75)$$

Then setting $\underline{u} := -\mathbf{R}^{-1} \mathbf{G}^T \tilde{\mathbf{P}} \underline{z}_i$, where scalar $\tilde{\mathbf{P}} > 0$ is a design parameter, and having in mind that \underline{z}_i is scalar (thus $\lambda_i \mathbb{I} = \lambda_i$), we get:

$$\dot{\underline{z}}_i = \left(\lambda_i - \mathbf{G} \mathbf{R}^{-1} \mathbf{G}^T \tilde{\mathbf{P}} \right) \underline{z}_i \quad (4.76)$$

Let λ_{Ki} be the desired eigenvalue of the preceding reduced-order model. Then we shall have:

$$\lambda_{Ki} = \lambda_i - \mathbf{G} \mathbf{R}^{-1} \mathbf{G}^T \tilde{\mathbf{P}} \quad (4.77)$$

Thus, matrix $\tilde{\mathbf{P}}$ reads:

$$\tilde{\mathbf{P}} = \frac{\lambda_i - \lambda_{Ki}}{\mathbf{G}\mathbf{R}^{-1}\mathbf{G}^T} \quad (4.78)$$

The state weighting matrix \mathbf{Q}_i that will shift the open-loop eigenvalue λ_i to the closed-loop eigenvalue λ_{Ki} is obtained through the following identification: $\dot{z}_i^T \tilde{\mathbf{Q}}_i z_i = \underline{x}^T \mathbf{Q}_i \underline{x}$. We finally get:

$$z_i = \underline{v}^T \underline{x} := \mathbf{C}^T \underline{x} \Rightarrow \mathbf{Q}_i = \mathbf{C} \tilde{\mathbf{Q}}_i \mathbf{C}^T \quad (4.79)$$

Once matrix $\tilde{\mathbf{P}}$ has been computed, matrix $\tilde{\mathbf{Q}}_i$ is obtained thanks to the corresponding algebraic Riccati equation:

$$\begin{aligned} \mathbf{0} &= \tilde{\mathbf{P}}\lambda_i + \lambda_i\tilde{\mathbf{P}} - \tilde{\mathbf{P}}\mathbf{G}\mathbf{R}^{-1}\mathbf{G}^T\tilde{\mathbf{P}} + \tilde{\mathbf{Q}}_i \\ \Leftrightarrow \tilde{\mathbf{Q}}_i &= -2\lambda_i\tilde{\mathbf{P}} + \tilde{\mathbf{P}}\mathbf{G}\mathbf{R}^{-1}\mathbf{G}^T\tilde{\mathbf{P}} \end{aligned} \quad (4.80)$$

4.3.4 Shifting a pair of complex conjugate eigenvalues

The procedure to shift a pair of complex conjugate eigenvalues follows the same idea: let λ_i and $\bar{\lambda}_i$ be a pair of complex conjugate eigenvalues of \mathbf{A} . We wish to shift λ_i and $\bar{\lambda}_i$ to λ_{Ki} and $\bar{\lambda}_{Ki}$.

Let \underline{v} and $\bar{\underline{v}}$ be a pair *left* eigenvectors of \mathbf{A} . In other words, \underline{v} and $\bar{\underline{v}}$ is a pair of (right) eigenvector of \mathbf{A}^T corresponding to λ_i :

$$\begin{aligned} \begin{bmatrix} \underline{v}^T & \bar{\underline{v}}^T \end{bmatrix} \mathbf{A} &= \begin{bmatrix} \underline{v}^T & \bar{\underline{v}}^T \end{bmatrix} \begin{bmatrix} \lambda_i & 0 \\ 0 & \bar{\lambda}_i \end{bmatrix} \\ \Leftrightarrow \mathbf{A}^T \begin{bmatrix} \underline{v} & \bar{\underline{v}} \end{bmatrix} &= \begin{bmatrix} \underline{v} & \bar{\underline{v}} \end{bmatrix} \begin{bmatrix} \lambda_i & 0 \\ 0 & \bar{\lambda}_i \end{bmatrix} \end{aligned} \quad (4.81)$$

In order to manipulate real values, we will use the real part and the imaginary part of the preceding equation. Denoting $\lambda_i := a + jb$, that is $a := \text{Re}(\lambda_i)$ and $b := \text{Im}(\lambda_i)$, the preceding relation is equivalently replaced by the following one:

$$\begin{aligned} \mathbf{A}^T \begin{bmatrix} \underline{v} & \bar{\underline{v}} \end{bmatrix} &= \begin{bmatrix} \underline{v} & \bar{\underline{v}} \end{bmatrix} \begin{bmatrix} \lambda_i & 0 \\ 0 & \bar{\lambda}_i \end{bmatrix} \\ \Leftrightarrow \mathbf{A}^T \begin{bmatrix} \text{Re}(\underline{v}) & \text{Im}(\underline{v}) \end{bmatrix} &= \begin{bmatrix} \text{Re}(\underline{v}) & \text{Im}(\underline{v}) \end{bmatrix} \begin{bmatrix} a & -b \\ b & a \end{bmatrix} \end{aligned} \quad (4.82)$$

Then define z_i as follows:

$$z_i := \mathbf{C}^T \underline{x} \text{ where } \mathbf{C} = \begin{bmatrix} \text{Re}(\underline{v}) & \text{Im}(\underline{v}) \end{bmatrix} \quad (4.83)$$

Using the fact that \underline{v} and $\bar{\underline{v}}$ is a pair of (right) eigenvector of \mathbf{A}^T , we get:

$$\dot{z}_i = \mathbf{A}_i z_i + \mathbf{G} \underline{u} \quad (4.84)$$

where:

$$\begin{cases} \mathbf{G} = \mathbf{C}^T \mathbf{B} \\ \mathbf{A}_i = \begin{bmatrix} a & -b \\ b & a \end{bmatrix} \end{cases} \quad (4.85)$$

Then setting $\underline{u} = -\mathbf{R}^{-1}\mathbf{G}^T\tilde{\mathbf{P}}\underline{z}_i$, where 2×2 positive definite matrix $\tilde{\mathbf{P}}$ is a design parameter, we get:

$$\dot{\underline{z}}_i = \mathbf{A}_i \underline{z}_i \text{ where } \begin{cases} \mathbf{A}_i = \mathbf{A}_i - \mathbf{G}\mathbf{R}^{-1}\mathbf{G}^T\tilde{\mathbf{P}} \\ \tilde{\mathbf{P}} = \tilde{\mathbf{P}}^T = \begin{bmatrix} \tilde{p}_1 & \tilde{p}_2 \\ \tilde{p}_2 & \tilde{p}_3 \end{bmatrix} > 0 \end{cases} \quad (4.86)$$

Thus the closed-loop eigenvalues are the eigenvalues of matrix \mathbf{A}_i . Here the design process becomes a little bit more involved because parameters \tilde{p}_1 , \tilde{p}_2 and \tilde{p}_3 of matrix $\tilde{\mathbf{P}}$ shall be chosen to meet the desired complex conjugate closed-loop eigenvalues λ_{Ki} and $\bar{\lambda}_{Ki}$ while minimizing the trace of $\tilde{\mathbf{P}}$ (indeed it can be shown that $\min(J_i) = \min(\text{tr}(\tilde{\mathbf{P}}))$). The design process has been described by Arar & Sawan⁵.

Alternatively, we can choose the three coefficients \tilde{q}_1 , \tilde{q}_2 and \tilde{q}_3 of matrix $\tilde{\mathbf{Q}}_i = \tilde{\mathbf{Q}}_i^T \geq 0$ such that the eigenvalues with negative real part of the following Hamiltonian matrix $\tilde{\mathbf{H}}_i$ correspond to the desired eigenvalues λ_{Ki} and $\bar{\lambda}_{Ki}$, as proposed by Fujinaka & Omatu⁶.

Thus the problem consists to find matrix $\tilde{\mathbf{Q}}_i$:

$$\tilde{\mathbf{Q}}_i = \begin{bmatrix} \tilde{q}_1 & \tilde{q}_2 \\ \tilde{q}_2 & \tilde{q}_3 \end{bmatrix} = \tilde{\mathbf{Q}}_i^T \geq 0 \quad (4.87)$$

such that:

$$\det(s\mathbb{I} - \tilde{\mathbf{H}}_i) = (s - \lambda_{Ki})(s - \bar{\lambda}_{Ki})(s + \lambda_{Ki})(s + \bar{\lambda}_{Ki}) = s^4 + c_2 s^2 + c_0 \quad (4.88)$$

where:

$$\tilde{\mathbf{H}}_i = \begin{bmatrix} \mathbf{A}_i & -\mathbf{G}\mathbf{R}^{-1}\mathbf{G}^T \\ -\tilde{\mathbf{Q}}_i & -\mathbf{A}_i \end{bmatrix} \quad (4.89)$$

Once matrix $\tilde{\mathbf{Q}}_i$ has been computed, matrix \mathbf{Q} is obtained as follows:

$$\mathbf{Q} = \mathbf{C}\tilde{\mathbf{Q}}_i\mathbf{C}^T \quad (4.90)$$

4.3.5 Sequential pole shifting via reduced-order models

When the imaginary part of the shifted eigenvalues is preserved, that is when $\text{Im}(\lambda_{Ki}) = \text{Im}(\lambda_i)$ and $\text{Im}(\bar{\lambda}_{Ki}) = \text{Im}(\bar{\lambda}_i)$, then the design process can be simplified by using the mirror property underlined by Amin⁴ and presented in Section 4.3.1: given a controllable pair $(\mathbf{A}_i, \mathbf{G})$, a positive definite symmetric matrix \mathbf{R} and a positive real constant α , then the following algebraic Riccati equation has a unique positive definite solution $\tilde{\mathbf{P}} = \tilde{\mathbf{P}}^T > 0$:

$$(\mathbf{A}_i + \alpha\mathbb{I})^T\tilde{\mathbf{P}} + \tilde{\mathbf{P}}(\mathbf{A}_i + \alpha\mathbb{I}) - \tilde{\mathbf{P}}\mathbf{G}\mathbf{R}^{-1}\mathbf{G}^T\tilde{\mathbf{P}} = \mathbf{0} \quad (4.91)$$

⁵Abdul-Razzaq S. Arar, Mahmoud E. Sawan, Optimal pole placement with prescribed eigenvalues for continuous systems, Journal of the Franklin Institute, Volume 330, Issue 5, September 1993, Pages 985-994

⁶Toru Fujinaka, Sigeru Omatu, Pole Placement Using Optimal Regulators, IEEJ Transactions on Electronics Information and Systems 121(1):240-245, January 2001, DOI:10.1541/ieejieiss1987.121.1_240

Moreover the feedback control law $\underline{u} = -\mathbf{K}_i \underline{x}$ shift the pair of complex conjugate eigenvalues $(\lambda_i, \bar{\lambda}_i)$ of matrix \mathbf{A} to a pair of complex conjugate eigenvalues $(\lambda_{Ki}, \bar{\lambda}_{Ki})$ as follows, assuming $\alpha + \text{Re}(\lambda_i) \geq 0$:

$$\begin{cases} \mathbf{P}_i = \mathbf{C} \tilde{\mathbf{P}} \mathbf{C}^T \\ \mathbf{Q}_i = 2\alpha \mathbf{P}_i \\ \mathbf{K}_i = \mathbf{R}^{-1} \mathbf{B}^T \mathbf{P}_i = \mathbf{R}^{-1} \mathbf{G}^T \tilde{\mathbf{P}} \mathbf{C}^T \end{cases} \Rightarrow \begin{cases} \text{Re}(\lambda_{Ki}) = -(2\alpha + \text{Re}(\lambda_i)) \\ \text{Im}(\lambda_{Ki}) = \text{Im}(\lambda_i) \end{cases} \quad (4.92)$$

The design process proposed by Amin⁴ to shift several eigenvalues recursively is the following:

1. Set $i = 1$ and $\mathbf{A}_1 = \mathbf{A}$.
2. Let λ_i be the eigenvalue of matrix \mathbf{A}_i which is desired to be shifted:
 - Assume that λ_i is real. We wish to shift λ_i to $\lambda_{Ki} \leq \lambda_i$. Then compute a (right) eigenvector \underline{v} of \mathbf{A}_i^T corresponding to λ_i . In other words \underline{v}^T is the *left* eigenvector of \mathbf{A}_i : $\underline{v}^T \mathbf{A}_i = \lambda_i \underline{v}^T$. Then compute \mathbf{C} , \mathbf{G} , α and \mathbf{A}_i defined by:

$$\begin{cases} \mathbf{C} = \underline{v} \\ \mathbf{G} = \mathbf{C}^T \mathbf{B} \\ \alpha = -\frac{\lambda_{Ki} + \lambda_i}{2} \geq 0 \text{ where } \lambda_{Ki} \leq \lambda_i \in \mathbb{R} \\ \mathbf{A}_i = \lambda_i \in \mathbb{R} \end{cases} \quad (4.93)$$

- Now assume that $\lambda_i = a + jb$ is complex. We wish to shift λ_i and $\bar{\lambda}_i$ to λ_{Ki} and $\bar{\lambda}_{Ki}$ where:

$$\begin{cases} \text{Re}(\lambda_{Ki}) \leq \text{Re}(\lambda_i) := a \\ \text{Im}(\lambda_{Ki}) = \text{Im}(\lambda_i) := b \end{cases} \quad (4.94)$$

This means that the shifted poles shall have the same imaginary parts than the original ones. Then compute (right) eigenvectors $(\underline{v}_1, \underline{v}_2)$ of \mathbf{A}_i^T corresponding to λ_i and $\bar{\lambda}_i$. In other words $(\underline{v}_1^T, \underline{v}_2^T)$ are the *left* eigenvectors of \mathbf{A}_i : $\begin{bmatrix} \underline{v}_1^T \\ \underline{v}_2^T \end{bmatrix} \mathbf{A}_i = \begin{bmatrix} \lambda_i & 0 \\ 0 & \bar{\lambda}_i \end{bmatrix} \begin{bmatrix} \underline{v}_1^T \\ \underline{v}_2^T \end{bmatrix}$. Then compute \mathbf{C} , \mathbf{G} , α and \mathbf{A}_i defined by:

$$\begin{cases} \underline{v}_1 = \bar{\underline{v}}_2 \Rightarrow \mathbf{C} = \begin{bmatrix} \text{Re}(\underline{v}_1) & \text{Im}(\underline{v}_1) \end{bmatrix} \\ \mathbf{G} = \mathbf{C}^T \mathbf{B} \\ \alpha = -\frac{\text{Re}(\lambda_{Ki} + \lambda_i)}{2} \geq 0 \\ \lambda_i = a + jb \in \mathbb{C} \Rightarrow \mathbf{A}_i = \begin{bmatrix} a & -b \\ b & a \end{bmatrix} \end{cases} \quad (4.95)$$

3. Compute $\tilde{\mathbf{P}} = \tilde{\mathbf{P}}^T > 0$, which is defined as the unique positive definite solution of the following algebraic Riccati equation:

$$(\mathbf{A}_i + \alpha \mathbb{I})^T \tilde{\mathbf{P}} + \tilde{\mathbf{P}} (\mathbf{A}_i + \alpha \mathbb{I}) - \tilde{\mathbf{P}} \mathbf{G} \mathbf{R}^{-1} \mathbf{G}^T \tilde{\mathbf{P}} = \mathbf{0} \quad (4.96)$$

Alternatively, $\tilde{\mathbf{P}}$ can be defined as follows:

$$\tilde{\mathbf{P}} = \mathbf{X}^{-1} \quad (4.97)$$

where \mathbf{X} is the solution of the following Lyapunov equation:

$$(\mathbf{A}_i + \alpha\mathbb{I})\mathbf{X} + \mathbf{X}(\mathbf{A}_i + \alpha\mathbb{I})^T = \mathbf{G}\mathbf{R}^{-1}\mathbf{G}^T \quad (4.98)$$

4. Compute \mathbf{P}_i , \mathbf{Q}_i and \mathbf{K}_i as follows:

$$\begin{cases} \mathbf{P}_i = \mathbf{C}\tilde{\mathbf{P}}\mathbf{C}^T \\ \mathbf{Q}_i = 2\alpha\mathbf{P}_i \\ \mathbf{K}_i = \mathbf{R}^{-1}\mathbf{B}^T\mathbf{P}_i = \mathbf{R}^{-1}\mathbf{G}^T\tilde{\mathbf{P}}\mathbf{C}^T \end{cases} \quad (4.99)$$

5. Set $i = i + 1$ and $\mathbf{A}_i = \mathbf{A}_{i-1} - \mathbf{B}\mathbf{K}_{i-1}$. Go to step 2 if some others open-loop eigenvalues have to be shifted.

Once the loop is finished compute $\mathbf{P} = \sum_i \mathbf{P}_i$, $\mathbf{Q} = \sum_i \mathbf{Q}_i$ and $\mathbf{K} = \sum_i \mathbf{K}_i$. Gain \mathbf{K} is such that eigenvalues of $\mathbf{A} - \mathbf{B}\mathbf{K}$ are located to the desired values λ_{K_i} . Furthermore \mathbf{Q} is the weighting matrix for the state vector and \mathbf{P} is the positive definite solution of the corresponding algebraic Riccati equation.

4.4 Frequency domain approach

4.4.1 Non optimal pole assignment

We have seen in (3.138) that thanks to the Hsu-Chen theorem the closed-loop characteristic polynomial $\det(s\mathbb{I} - \mathbf{A} + \mathbf{B}\mathbf{K})$ reads as follows:

$$\det(s\mathbb{I} - \mathbf{A} + \mathbf{B}\mathbf{K}) = \det(s\mathbb{I} - \mathbf{A}) \det(\mathbb{I} + \mathbf{K}\Phi(s)\mathbf{B}) \quad (4.100)$$

Let $D(s) = \det(s\mathbb{I} - \mathbf{A})$ be the determinant of $\Phi(s)$, that is the plant characteristic polynomial, and $\mathbf{N}_{ol}(s) = \text{adj}(s\mathbb{I} - \mathbf{A})\mathbf{B}$ be the adjugate matrix of $s\mathbb{I} - \mathbf{A}$ times matrix \mathbf{B} :

$$\Phi(s)\mathbf{B} = (s\mathbb{I} - \mathbf{A})^{-1}\mathbf{B} = \frac{\text{adj}(s\mathbb{I} - \mathbf{A})\mathbf{B}}{\det(s\mathbb{I} - \mathbf{A})} := \frac{\mathbf{N}_{ol}(s)}{D(s)} \quad (4.101)$$

Consequently (4.100) reads:

$$\det(s\mathbb{I} - \mathbf{A} + \mathbf{B}\mathbf{K}) = \det(D(s)\mathbb{I} + \mathbf{K}\mathbf{N}_{ol}(s)) \quad (4.102)$$

As soon as λ_{K_i} is a desired closed-loop eigenvalue then the following relation holds:

$$\det(D(s)\mathbb{I} + \mathbf{K}\mathbf{N}_{ol}(s))|_{s=\lambda_{K_i}} = 0 \quad (4.103)$$

Consequently it is desired that matrix $D(s)\mathbb{I} + \mathbf{K}\mathbf{N}_{ol}(s)|_{s=\lambda_{K_i}}$ is singular. Let ω_i be a vector belonging to the kernel of $D(s)\mathbb{I} + \mathbf{K}\mathbf{N}_{ol}(s)|_{s=\lambda_{K_i}}$. Thus replacing s by λ_{K_i} we can write:

$$(D(\lambda_{K_i})\mathbb{I} + \mathbf{K}\mathbf{N}_{ol}(\lambda_{K_i}))\omega_i = \underline{0} \quad (4.104)$$

Actually, vector $\underline{\omega}_i \neq \underline{0}$ can be used as a design parameter.

Alternatively, when making the parallel that λ_i is an eigenvalue of matrix \mathbf{A} as soon as $\det(s\mathbb{I} - \mathbf{A})|_{s=\lambda_i} = 0$, we conclude that $D(\lambda_{Ki})$ is an eigenvalue of matrix $-\mathbf{KN}_{ol}(\lambda_{Ki})$, and thus $\underline{\omega}_i$ is an eigenvector of $-\mathbf{KN}_{ol}(\lambda_{Ki})$ corresponding to the eigenvalue $D(\lambda_{Ki})$. This remark can be extended to the output feedback case where $\mathbf{N}_{ol}(s) = \mathbf{C} \operatorname{adj}(s\mathbb{I} - \mathbf{A}) \mathbf{B}$.

In order to get gain \mathbf{K} the preceding relation is rewritten as follows:

$$\mathbf{KN}_{ol}(\lambda_{Ki})\underline{\omega}_i = -D(\lambda_{Ki})\underline{\omega}_i \quad (4.105)$$

This relation does not lead to the value of gain \mathbf{K} as soon as $\mathbf{N}_{ol}(\lambda_{Ki})\underline{\omega}_i$ is a vector which is not invertible. Nevertheless assuming that n denotes the order of state matrix \mathbf{A} we can apply this relation for the n desired closed-loop eigenvalues. We get:

$$\mathbf{K} \begin{bmatrix} \underline{v}_{K1} & \cdots & \underline{v}_{Kn} \end{bmatrix} = - \begin{bmatrix} \underline{p}_1 & \cdots & \underline{p}_n \end{bmatrix} \quad (4.106)$$

where vectors \underline{v}_{Ki} and \underline{p}_i are given by:

$$\begin{cases} \underline{v}_{Ki} = \mathbf{N}_{ol}(\lambda_{Ki})\underline{\omega}_i \\ \underline{p}_i = D(\lambda_{Ki})\underline{\omega}_i \end{cases} \quad (4.107)$$

We finally get the following expression of gain \mathbf{K} :

$$\mathbf{K} = - \begin{bmatrix} \underline{p}_1 & \cdots & \underline{p}_n \end{bmatrix} \begin{bmatrix} \underline{v}_{K1} & \cdots & \underline{v}_{Kn} \end{bmatrix}^{-1} \quad (4.108)$$

4.4.2 Assignment of weighting matrices \mathbf{Q} and \mathbf{R}

The starting point is the Kalman equality (3.143) that we recall hereafter:

$$(\mathbb{I} + \mathbf{K}\Phi(-s)\mathbf{B})^T \mathbf{R} (\mathbb{I} + \mathbf{K}\Phi(s)\mathbf{B}) = \mathbf{R} + (\Phi(-s)\mathbf{B})^T \mathbf{Q} (\Phi(s)\mathbf{B}) \quad (4.109)$$

Using the fact that $\det(\mathbf{XY}) = \det(\mathbf{X}) \det(\mathbf{Y})$ leads to the following result:

$$\begin{aligned} \det \left((\mathbb{I} + \mathbf{K}\Phi(-s)\mathbf{B})^T \right) \det(\mathbf{R}) \det \left((\mathbb{I} + \mathbf{K}\Phi(s)\mathbf{B}) \right) &= \det \left(\mathbf{R} + (\Phi(-s)\mathbf{B})^T \mathbf{Q} (\Phi(s)\mathbf{B}) \right) \\ \Leftrightarrow \det \left((\mathbb{I} + \mathbf{K}\Phi(-s)\mathbf{B})^T \right) \det \left((\mathbb{I} + \mathbf{K}\Phi(s)\mathbf{B}) \right) &= \det \left(\mathbb{I} + \mathbf{R}^{-1} (\Phi(-s)\mathbf{B})^T \mathbf{Q} (\Phi(s)\mathbf{B}) \right) \end{aligned} \quad (4.110)$$

On the other hand, let $D(s)$ be the open-loop characteristic polynomial and $\beta(s)$ be the closed-loop characteristic polynomial:

$$\begin{cases} D(s) = \det(s\mathbb{I} - \mathbf{A}) \\ \beta(s) = \det(s\mathbb{I} - \mathbf{A} + \mathbf{BK}) \end{cases} \quad (4.111)$$

As in the previous section, let $\mathbf{N}_{ol}(s)$ be the following polynomial matrix:

$$\mathbf{N}_{ol}(s) := \operatorname{adj}(s\mathbb{I} - \mathbf{A}) \mathbf{B} \quad (4.112)$$

Then we get:

$$\Phi(s) := (s\mathbb{I} - \mathbf{A})^{-1} \Rightarrow \Phi(s) \mathbf{B} = (s\mathbb{I} - \mathbf{A})^{-1} \mathbf{B} := \frac{\mathbf{N}_{ol}(s)}{D(s)} \quad (4.113)$$

Furthermore the Hsu-Chen equality (3.138) reads as follows with those notations:

$$\begin{aligned} \det(s\mathbb{I} - \mathbf{A} + \mathbf{BK}) &= \det(s\mathbb{I} - \mathbf{A}) \det(\mathbb{I} + \mathbf{K}\Phi(s)\mathbf{B}) \\ \Leftrightarrow \det(\mathbb{I} + \mathbf{K}\Phi(s)\mathbf{B}) &= \frac{\det(s\mathbb{I} - \mathbf{A} + \mathbf{BK})}{\det(s\mathbb{I} - \mathbf{A})} := \frac{\beta(s)}{D(s)} \end{aligned} \quad (4.114)$$

Finally, using the fact that $\det(\mathbf{X}^T) = \det(\mathbf{X})$, relation (4.110) becomes:

$$\frac{\beta(-s)}{D(-s)} \frac{\beta(s)}{D(s)} = \det\left(\mathbb{I} + \mathbf{R}^{-1} (\Phi(-s)\mathbf{B})^T \mathbf{Q} (\Phi(s)\mathbf{B})\right) \quad (4.115)$$

We finally get the following result where $\det\left(\mathbb{I} + \mathbf{R}^{-1} (\Phi(-s)\mathbf{B})^T \mathbf{Q} (\Phi(s)\mathbf{B})\right)$ is a rational fraction whose denominator is $D(s)D(-s)$, that is the denominator of $\Phi(-s)\Phi(s)$:

$$\begin{aligned} \beta(s)\beta(-s) &= D(s)D(-s) \det\left(\mathbb{I} + \mathbf{R}^{-1} (\Phi(-s)\mathbf{B})^T \mathbf{Q} (\Phi(s)\mathbf{B})\right) \\ &= D(s)D(-s) \det\left(\mathbb{I} + \mathbf{R}^{-1} \left(\frac{\mathbf{N}_{ol}(-s)}{D(-s)}\right)^T \mathbf{Q} \frac{\mathbf{N}_{ol}(s)}{D(s)}\right) \\ &= \det\left(D(s)D(-s)\mathbb{I} + \mathbf{R}^{-1}\mathbf{N}_{ol}(-s)^T \mathbf{Q} \mathbf{N}_{ol}(s)\right) \end{aligned} \quad (4.116)$$

Thus the closed-loop eigenvalues are the roots λ_{Ki} with negative real part such that:

$$\det\left(D(s)D(-s)\mathbb{I} + \mathbf{R}^{-1}\mathbf{N}_{ol}(-s)^T \mathbf{Q} \mathbf{N}_{ol}(s)\right)\Big|_{s=\lambda_{Ki}} = 0 \quad (4.117)$$

Relation (4.117) indicates there exists eigenvectors $\underline{\omega}_i \neq \underline{0}$ such that for a given closed-loop eigenvalue λ_{Ki} the following relation holds⁷:

$$\boxed{\left(D(-\lambda_{Ki})D(\lambda_{Ki})\mathbb{I} + \mathbf{R}^{-1} (\mathbf{N}_{ol}(-\lambda_{Ki}))^T \mathbf{Q} \mathbf{N}_{ol}(\lambda_{Ki})\right) \underline{\omega}_i = \underline{0}} \quad (4.118)$$

Let n be the order of state matrix \mathbf{A} . Once eigenvector $\underline{\omega}_i \neq \underline{0}$ has been obtained for each λ_{Ki} , relation (4.108) can be used to compute the optimal gain \mathbf{K} as follows:

$$\mathbf{K} = - \left[\begin{array}{ccc} \underline{p}_1 & \cdots & \underline{p}_n \end{array} \right] \left(\left[\begin{array}{ccc} \underline{v}_{K1} & \cdots & \underline{v}_{Kn} \end{array} \right] \right)^{-1} \quad (4.119)$$

where vectors \underline{v}_{Ki} and \underline{p}_i are given as in the non optimal pole assignment problem:

$$\boxed{\begin{cases} \underline{v}_{Ki} = \mathbf{N}_{ol}(\lambda_{Ki}) \underline{\omega}_i \\ \underline{p}_i = D(\lambda_{Ki}) \underline{\omega}_i \end{cases}} \quad (4.120)$$

⁷L.S. Shieh, H.M. Dib, R.E. Yates, Sequential design of linear quadratic state regulators via the optimal root-locus techniques, IEE Proceedings D - Control Theory and Applications, Volume: 135, Issue: 4, July 1988, DOI: 10.1049/ip-d.1988.0040

It is worth noticing that if the open-loop eigenvalue λ_i is desired to be kept in the closed-loop, then applying (4.118) with relations $D(\lambda_i) = 0$ and $\lambda_i = \lambda_{K_i}$ imply that $\underline{p}_i = \underline{0}$ and that \underline{v}_{K_i} shall be chosen such that $\mathbf{Q}\underline{v}_{K_i} = \underline{0}$. Indeed:

$$\boxed{\begin{cases} \left(D(-\lambda_{K_i})D(\lambda_{K_i})\mathbb{I} + \mathbf{R}^{-1}(\mathbf{N}_{ol}(-\lambda_{K_i}))^T \mathbf{Q}\mathbf{N}_{ol}(\lambda_{K_i}) \right) \underline{\omega}_i = \underline{0} \\ D(\lambda_i) = 0 \\ \lambda_i = \lambda_{K_i} \end{cases}} \quad (4.121)$$

$$\Rightarrow \begin{cases} \underline{p}_i = D(\lambda_{K_i})\underline{\omega}_i = D(\lambda_i)\underline{\omega}_i = \underline{0} \\ \mathbf{Q}\mathbf{N}_{ol}(\lambda_i)\underline{\omega}_i = \mathbf{Q}\underline{v}_{K_i} = \underline{0} \end{cases}$$

On the other hand, if λ_{K_i} and $\underline{\omega}_i$ are set, then \mathbf{Q} and \mathbf{R} shall be chosen such that (4.118) holds $\forall i$. Once matrix $\mathbf{R} = \mathbf{R} > 0$ has been set, matrix \mathbf{Q} can be assumed to be a real diagonal matrix whose coefficients q_i shall be computed to comply with (4.118):

$$\mathbf{Q} = \mathbf{Q}^T = \begin{bmatrix} q_1 & & \\ & \ddots & \\ & & q_n \end{bmatrix} \in \mathbb{R}^n \quad (4.122)$$

Nevertheless, take care that the computed matrix $\mathbf{Q} = \mathbf{Q}^T$ may *not* be positive semi-definite in that case.

Finally, for *single input* system, $\underline{\omega}_i := \omega_i \neq 0$ and $\mathbf{R} := R > 0$ are scalars and (4.118) reduces as follows:

$$\omega_i \neq 0 \in \mathbb{R} \Rightarrow D(-\lambda_{K_i})D(\lambda_{K_i}) + (\mathbf{N}_{ol}(-\lambda_{K_i}))^T \frac{\mathbf{Q}}{R} \mathbf{N}_{ol}(\lambda_{K_i}) = 0 \quad \forall i \quad (4.123)$$

Example 4.1. *We consider the following state equation:*

$$\dot{\underline{x}} = \begin{bmatrix} 0 & 1 \\ 10 & -9 \end{bmatrix} \underline{x} + \begin{bmatrix} 0 \\ 1 \end{bmatrix} \underline{u} \quad (4.124)$$

We wish to design an optimal state feedback controller such that the closed-loop poles are located at $\{\lambda_{K_1} = -10, \lambda_{K_2} = -2\}$.

To solve this problem, we first observe that the eigenvalues of \mathbf{A} are $\{\lambda_1 = -10, \lambda_2 = 1\}$. Thus the problem consists in preserving $\lambda_1 = -10$ in the state feedback loop while shifting $\lambda_2 = 1$ towards $\lambda_{K_2} = -2$. Because we are looking for an optimal state feedback controller, we have to select matrix $\mathbf{Q} = \mathbf{Q}^T \geq 0$ and $R > 0$ to achieve those specifications.

The characteristic polynomial $D(s)$ of state matrix \mathbf{A} reads:

$$D(s) = \det(s\mathbb{I} - \mathbf{A}) = s^2 + 9s - 10 \Rightarrow \begin{cases} D(\lambda_{K_1}) = D(-10) = 0 \\ D(\lambda_{K_2}) = D(-2) = -24 \end{cases} \quad (4.125)$$

In addition, let $\mathbf{N}_{ol}(s)$ be the following polynomial matrix:

$$\begin{aligned} \mathbf{N}_{ol}(s) &:= \text{adj}(s\mathbb{I} - \mathbf{A}) \mathbf{B} = \begin{bmatrix} s+9 & 1 \\ 10 & s \end{bmatrix} \begin{bmatrix} 0 \\ 1 \end{bmatrix} = \begin{bmatrix} 1 \\ s \end{bmatrix} \\ &\Rightarrow \begin{cases} \mathbf{N}_{ol}(\lambda_{K1}) = \mathbf{N}_{ol}(-10) = \begin{bmatrix} 1 & -10 \end{bmatrix}^T \\ \mathbf{N}_{ol}(-\lambda_{K1}) = \mathbf{N}_{ol}(10) = \begin{bmatrix} 1 & 10 \end{bmatrix}^T \\ \mathbf{N}_{ol}(\lambda_{K2}) = \mathbf{N}_{ol}(-2) = \begin{bmatrix} 1 & -2 \end{bmatrix}^T \\ \mathbf{N}_{ol}(-\lambda_{K2}) = \mathbf{N}_{ol}(2) = \begin{bmatrix} 1 & 2 \end{bmatrix}^T \end{cases} \quad (4.126) \end{aligned}$$

Because we focus on a single input system, we use relation (4.123) to select $\mathbf{Q} = \mathbf{Q}^T \geq 0$ and $R > 0$. Furthermore we will assume that $\frac{\mathbf{Q}}{R}$ is a diagonal matrix:

$$\frac{\mathbf{Q}}{R} := \begin{bmatrix} q_{r1} & 0 \\ 0 & q_{r2} \end{bmatrix} \quad (4.127)$$

We get:

$$\begin{aligned} D(-\lambda_{Ki})D(\lambda_{Ki}) + (\mathbf{N}_{ol}(-\lambda_{Ki}))^T \frac{\mathbf{Q}}{R} \mathbf{N}_{ol}(\lambda_{Ki}) &= 0 \\ \Leftrightarrow \begin{cases} q_{r1} - 100q_{r2} = 0 \\ q_{r1} - 4q_{r2} - 288 = 0 \end{cases} &\Leftrightarrow \begin{bmatrix} 1 & -100 \\ 1 & -4 \end{bmatrix} \begin{bmatrix} q_{r1} \\ q_{r2} \end{bmatrix} = \begin{bmatrix} 0 \\ 288 \end{bmatrix} \quad (4.128) \end{aligned}$$

We finally get:

$$\begin{aligned} \begin{bmatrix} q_{r1} \\ q_{r2} \end{bmatrix} &= \begin{bmatrix} 1 & -100 \\ 1 & -4 \end{bmatrix}^{-1} \begin{bmatrix} 0 \\ 288 \end{bmatrix} = \begin{bmatrix} 300 \\ 3 \end{bmatrix} \\ &\Rightarrow \frac{\mathbf{Q}}{R} := \begin{bmatrix} q_{r1} & 0 \\ 0 & q_{r2} \end{bmatrix} = \begin{bmatrix} 300 & 0 \\ 0 & 3 \end{bmatrix} \quad (4.129) \end{aligned}$$

■

4.5 Poles assignment in optimal regulator through matrix inequalities

In this section a method for designing linear quadratic regulator with prescribed closed-loop pole is presented.

Let $\underline{\Lambda}_{cl} = \{\lambda_1, \lambda_2, \dots, \lambda_n\}$ be a set of prescribed closed-loop eigenvalues, where $Re(\lambda_i) < 0$ and $\lambda_i \in \underline{\Lambda}_{cl}$ implies that the complex conjugate of λ_i , which is denoted λ_i^* , belongs also to $\underline{\Lambda}_{cl}$. The problem consists in finding a state feedback controller $u = -\mathbf{K}\underline{x}$ such that the eigenvalues of $\mathbf{A} - \mathbf{BK}$, which are denoted $\lambda(\mathbf{A} - \mathbf{BK})$, belongs to $\underline{\Lambda}_{cl}$:

$$\lambda(\mathbf{A} - \mathbf{BK}) = \underline{\Lambda}_{cl} \quad (4.130)$$

while minimizing the quadratic performance index $J(u(t))$ for some $\mathbf{Q} > 0$ and $\mathbf{R} > 0$.

$$J(u(t)) = \frac{1}{2} \int_0^{\infty} (\underline{x}^T(t) \mathbf{Q} \underline{x}(t) + u^T(t) \mathbf{R} u(t)) dt \quad (4.131)$$

We provide in that section the material written by He, Cai and Han⁸. Assume that (\mathbf{A}, \mathbf{B}) is controllable. Then, the pole assignment problem is solvable if and only if there exist two matrices $\mathbf{X}_1 \in \mathbb{R}^{n \times n}$ and $\mathbf{X}_2 \in \mathbb{R}^{n \times n}$ such that the following matrix inequalities are satisfied:

$$\begin{cases} \mathbf{F}^T \mathbf{X}_2^T \mathbf{X}_1 + \mathbf{X}_1^T \mathbf{X}_2 \mathbf{F} + \mathbf{X}_2^T \mathbf{B} \mathbf{R}^{-1} \mathbf{B}^T \mathbf{X}_2 \leq 0 \\ \mathbf{X}_1^T \mathbf{X}_2 = \mathbf{X}_2^T \mathbf{X}_1 > 0 \end{cases} \quad (4.132)$$

where \mathbf{F} is any matrix such that $\lambda(\mathbf{F}) = \underline{\Delta}_{cl}$ and $(\mathbf{X}_1, \mathbf{X}_2)$ satisfies the following generalized Sylvester matrix equation⁹:

$$\mathbf{A} \mathbf{X}_1 - \mathbf{X}_1 \mathbf{F} = \mathbf{B} \mathbf{R}^{-1} \mathbf{B}^T \mathbf{X}_2 \quad (4.133)$$

If $(\mathbf{X}_1, \mathbf{X}_2)$ is a feasible solution to the above two inequalities, then the weighting matrix \mathbf{Q} in the quadratic performance index $J(u(t))$ can be chosen as follows:

$$\mathbf{Q} = -\mathbf{A}^T \mathbf{X}_2 \mathbf{X}_1^{-1} - \mathbf{X}_2 \mathbf{F} \mathbf{X}_1^{-1} \quad (4.134)$$

In addition the solution the corresponding Riccati Algebraic equation reads:

$$\mathbf{P} = \mathbf{X}_2 \mathbf{X}_1^{-1} \quad (4.135)$$

The starting point to get this result is the fact that there must exist an eigenvector matrix \mathbf{X} such that the following formula involving Hamiltonian matrix \mathbf{H} holds:

$$\mathbf{H} \mathbf{X} = \mathbf{X} \mathbf{F} \quad (4.136)$$

Splitting the $2n \times n$ matrix \mathbf{X} into 2 square $n \times n$ matrices \mathbf{X}_1 and \mathbf{X}_2 and using the expression of the $2n \times 2n$ Hamiltonian matrix \mathbf{H} leads to the following relation:

$$\mathbf{X} = \begin{bmatrix} \mathbf{X}_1 \\ \mathbf{X}_2 \end{bmatrix} \Rightarrow \begin{bmatrix} \mathbf{A} & -\mathbf{B} \mathbf{R}^{-1} \mathbf{B}^T \\ -\mathbf{Q} & -\mathbf{A}^T \end{bmatrix} \begin{bmatrix} \mathbf{X}_1 \\ \mathbf{X}_2 \end{bmatrix} = \begin{bmatrix} \mathbf{X}_1 \\ \mathbf{X}_2 \end{bmatrix} \mathbf{F} \quad (4.137)$$

The preceding relation is expanded as follows:

$$\begin{cases} \mathbf{A} \mathbf{X}_1 - \mathbf{B} \mathbf{R}^{-1} \mathbf{B}^T \mathbf{X}_2 = \mathbf{X}_1 \mathbf{F} \\ -\mathbf{Q} \mathbf{X}_1 - \mathbf{A}^T \mathbf{X}_2 = \mathbf{X}_2 \mathbf{F} \end{cases} \Leftrightarrow \begin{cases} \mathbf{A} \mathbf{X}_1 - \mathbf{X}_1 \mathbf{F} = \mathbf{B} \mathbf{R}^{-1} \mathbf{B}^T \mathbf{X}_2 \\ \mathbf{Q} = -\mathbf{A}^T \mathbf{X}_2 \mathbf{X}_1^{-1} - \mathbf{X}_2 \mathbf{F} \mathbf{X}_1^{-1} \end{cases} \quad (4.138)$$

⁸Hua-Feng He, Guang-Bin Cai and Xiao-Jun Han, Optimal Pole Assignment of Linear Systems by the Sylvester Matrix Equations, Hindawi Publishing Corporation, Abstract and Applied Analysis, Volume 2014, Article ID 301375, <http://dx.doi.org/10.1155/2014/301375>

⁹An explicit solution to right factorization with application in eigenstructure assignment, Bin Zhou, Guangren Duan, Journal of Control Theory and Applications 08/2005; 3(3):275-279. DOI: 10.1007/s11768-005-0049-7

Since \mathbf{X}_1 is nonsingular matrix \mathbf{Q} is positive definite if and only if $\mathbf{X}_1^T \mathbf{Q} \mathbf{X}_1$ is positive definite. Using the first equation of (4.138) into the second one we get:

$$\begin{aligned} \mathbf{X}_1^T \mathbf{Q} \mathbf{X}_1 &= -\mathbf{X}_1^T \mathbf{A}^T \mathbf{X}_2 - \mathbf{X}_1^T \mathbf{X}_2 \mathbf{F} \\ &= -(\mathbf{A} \mathbf{X}_1)^T \mathbf{X}_2 - \mathbf{X}_1^T \mathbf{X}_2 \mathbf{F} \\ &= -(\mathbf{X}_1 \mathbf{F} + \mathbf{B} \mathbf{R}^{-1} \mathbf{B}^T \mathbf{X}_2)^T \mathbf{X}_2 - \mathbf{X}_1^T \mathbf{X}_2 \mathbf{F} \\ &= -(\mathbf{F}^T \mathbf{X}_2^T \mathbf{X}_1 + \mathbf{X}_1^T \mathbf{X}_2 \mathbf{F} + \mathbf{X}_2^T \mathbf{B} \mathbf{R}^{-1} \mathbf{B}^T \mathbf{X}_2) \end{aligned} \quad (4.139)$$

We recall the Schur's formula:

$$\begin{aligned} \det \left(\begin{bmatrix} \mathbf{A}_{11} & \mathbf{A}_{12} \\ \mathbf{A}_{21} & \mathbf{A}_{22} \end{bmatrix} \right) &= \det(\mathbf{A}_{22}) \det(\mathbf{A}_{11} - \mathbf{A}_{12} \mathbf{A}_{22}^{-1} \mathbf{A}_{21}) \\ &= \det(\mathbf{A}_{11}) \det(\mathbf{A}_{22} - \mathbf{A}_{21} \mathbf{A}_{11}^{-1} \mathbf{A}_{12}) \end{aligned} \quad (4.140)$$

Using the Schur's formula and denoting $\mathbf{S} = \mathbf{X}_1^T \mathbf{X}_2$ we finally get:

$$\mathbf{X}_1^T \mathbf{Q} \mathbf{X}_1 \geq 0 \Leftrightarrow \begin{bmatrix} \mathbf{F}^T \mathbf{S}^T + \mathbf{S} \mathbf{F} & \mathbf{X}_2^T \mathbf{B} \\ \mathbf{B}^T \mathbf{X}_2 & -\mathbf{R}^{-1} \end{bmatrix} \leq 0 \quad (4.141)$$

4.6 Model matching

4.6.1 cross-term in the performance index

Assume that the output $z(t)$ of interest is expressed as a linear combination of state vector $\underline{x}(t)$ and control $\underline{u}(t)$: $z(t) = \mathbf{N} \underline{x}(t) + \mathbf{D} \underline{u}(t)$. Thus the cost to be minimized reads:

$$\begin{cases} J(\underline{u}(t)) = \frac{1}{2} \int_0^\infty \underline{z}^T(t) \underline{z}(t) + \underline{u}^T(t) \mathbf{R}_1 \underline{u}(t) dt \\ \underline{z}(t) = \mathbf{N} \underline{x}(t) + \mathbf{D} \underline{u}(t) \\ \mathbf{R}_1 = \mathbf{R}_1^T > 0 \end{cases} \Rightarrow J(\underline{u}(t)) = \frac{1}{2} \int_0^\infty (\underline{x}^T(t) \mathbf{N}^T + \underline{u}^T(t) \mathbf{D}^T) (\mathbf{N} \underline{x}(t) + \mathbf{D} \underline{u}(t)) + \underline{u}^T(t) \mathbf{R}_1 \underline{u}(t) dt \quad (4.142)$$

Then we get a more general form of the quadratic performance index. Indeed the quadratic performance index can be rewritten as:

$$\begin{aligned} J(\underline{u}(t)) &= \frac{1}{2} \int_0^\infty \begin{bmatrix} \underline{x} \\ \underline{u} \end{bmatrix}^T \begin{bmatrix} \mathbf{Q} & \mathbf{S} \\ \mathbf{S}^T & \mathbf{R} \end{bmatrix} \begin{bmatrix} \underline{x} \\ \underline{u} \end{bmatrix} dt \\ &= \frac{1}{2} \int_0^\infty (\underline{x}^T(t) \mathbf{Q} \underline{x}(t) + \underline{u}^T(t) \mathbf{R} \underline{u}(t)) + 2 \underline{x}^T(t) \mathbf{S} \underline{u}(t) dt \end{aligned} \quad (4.143)$$

where:

$$\begin{cases} \mathbf{Q} = \mathbf{Q}^T := \mathbf{N}^T \mathbf{N} \geq 0 \\ \mathbf{R} = \mathbf{R}^T := \mathbf{D}^T \mathbf{D} + \mathbf{R}_1 > 0 \\ \mathbf{S} := \mathbf{N}^T \mathbf{D} \end{cases} \quad (4.144)$$

It can be seen that:

$$\underline{x}^T(t) \mathbf{Q} \underline{x}(t) + \underline{u}^T(t) \mathbf{R} \underline{u}(t) + 2 \underline{x}^T(t) \mathbf{S} \underline{u}(t) = \underline{x}^T(t) \mathbf{Q}_m \underline{x}(t) + \underline{v}^T(t) \mathbf{R} \underline{v}(t) \quad (4.145)$$

where:

$$\begin{cases} \mathbf{Q}_m = \mathbf{Q} - \mathbf{S} \mathbf{R}^{-1} \mathbf{S}^T \\ \underline{v}(t) = \underline{u}(t) + \mathbf{R}^{-1} \mathbf{S}^T \underline{x}(t) \end{cases} \quad (4.146)$$

Hence cost (4.143) can be rewritten as:

$$J(\underline{u}(t)) = \frac{1}{2} \int_0^\infty \underline{x}^T(t) \mathbf{Q}_m \underline{x}(t) + \underline{v}^T(t) \mathbf{R} \underline{v}(t) dt \quad (4.147)$$

Moreover the plant dynamics $\dot{\underline{x}}(t) = \mathbf{A}\underline{x}(t) + \mathbf{B}\underline{u}(t)$ is modified as follows:

$$\begin{aligned} \dot{\underline{x}} &= \mathbf{A}\underline{x}(t) + \mathbf{B}\underline{u}(t) \\ &= \mathbf{A}\underline{x}(t) + \mathbf{B}(\underline{v}(t) - \mathbf{R}^{-1}\mathbf{S}^T \underline{x}(t)) \\ &= \mathbf{A}_m \underline{x}(t) + \mathbf{B}\underline{v}(t) \end{aligned} \quad (4.148)$$

where $\mathbf{A}_m = \mathbf{A} - \mathbf{B}\mathbf{R}^{-1}\mathbf{S}^T$

Assuming that \mathbf{Q}_m (which is symmetric) is positive definite, we then get a standard LQR problem for which the optimal state feedback control law is given from (3.9):

$$\begin{cases} \underline{v}(t) = -\mathbf{R}^{-1}\mathbf{B}^T \mathbf{P} \underline{x}(t) \\ \underline{v}(t) = \underline{u}(t) + \mathbf{R}^{-1}\mathbf{S}^T \underline{x}(t) \end{cases} \Rightarrow \begin{cases} \underline{u}(t) = -\mathbf{K}\underline{x}(t) \\ \mathbf{K} = \mathbf{R}^{-1}(\mathbf{P}\mathbf{B} + \mathbf{S})^T \end{cases} \quad (4.149)$$

Where matrix \mathbf{P} is the positive definite matrix which solves the following algebraic Riccati equation (see (3.8)):

$$\mathbf{P}\mathbf{A}_m + \mathbf{A}_m^T \mathbf{P} - \mathbf{P}\mathbf{B}\mathbf{R}^{-1}\mathbf{B}^T \mathbf{P} + \mathbf{Q}_m = \mathbf{0} \quad (4.150)$$

It is worth noticing that robustness properties of the LQ state feedback are lost if the cost to be minimized contains a state-control cross-term as it is the case here.

4.6.2 Implicit reference model

Let \mathbf{A}_r be the desired closed-loop state matrix of the system and $\underline{e}(t)$ be the following error vector:

$$\underline{e}(t) := \dot{\underline{x}}(t) - \mathbf{A}_r \underline{x}(t) \quad (4.151)$$

In that section we consider the problem to find control $u(t)$ which minimizes the following performance index:

$$\begin{aligned} J(\underline{u}(t)) &= \frac{1}{2} \int_0^\infty \underline{e}^T(t) \underline{e}(t) dt \\ &= \frac{1}{2} \int_0^\infty (\dot{\underline{x}}(t) - \mathbf{A}_r \underline{x}(t))^T (\dot{\underline{x}}(t) - \mathbf{A}_r \underline{x}(t)) dt \end{aligned} \quad (4.152)$$

Expanding $\dot{\underline{x}}(t)$ we get:

$$\begin{aligned} J(\underline{u}(t)) &= \frac{1}{2} \int_0^\infty (\mathbf{A}\underline{x}(t) + \mathbf{B}\underline{u}(t) - \mathbf{A}_r \underline{x}(t))^T (\mathbf{A}\underline{x}(t) + \mathbf{B}\underline{u}(t) - \mathbf{A}_r \underline{x}(t)) dt \\ &= \frac{1}{2} \int_0^\infty ((\mathbf{A} - \mathbf{A}_r) \underline{x}(t) + \mathbf{B}\underline{u}(t))^T ((\mathbf{A} - \mathbf{A}_r) \underline{x}(t) + \mathbf{B}\underline{u}(t)) dt \end{aligned} \quad (4.153)$$

We get a cost to be minimized which contains a state-control cross-term:

$$J(\underline{u}(t)) = \frac{1}{2} \int_0^\infty (\underline{x}^T(t) \mathbf{Q} \underline{x}(t) + \underline{u}^T(t) \mathbf{R} \underline{u}(t)) + 2\underline{x}^T(t) \mathbf{N} \underline{u}(t) dt \quad (4.154)$$

Where:

$$\begin{cases} \mathbf{Q} = (\mathbf{A} - \mathbf{A}_r)^T (\mathbf{A} - \mathbf{A}_r) \\ \mathbf{R} = \mathbf{B}^T \mathbf{B} \\ \mathbf{N} = (\mathbf{A} - \mathbf{A}_r)^T \mathbf{B} \end{cases} \quad (4.155)$$

Then we can re-use the results of section 4.6.1. Let \mathbf{P} be the positive definite matrix which solves the following *algebraic Riccati* equation:

$$\mathbf{P}\mathbf{A}_m + \mathbf{A}_m^T \mathbf{P} - \mathbf{P}\mathbf{B}\mathbf{R}^{-1}\mathbf{B}^T \mathbf{P} + \mathbf{Q}_m = \mathbf{0} \quad (4.156)$$

Where:

$$\begin{cases} \mathbf{Q}_m = \mathbf{Q} - \mathbf{N}\mathbf{R}^{-1}\mathbf{N}^T \\ \mathbf{A}_m = \mathbf{A} - \mathbf{B}\mathbf{R}^{-1}\mathbf{N}^T \\ \underline{v}(t) = \underline{u}(t) + \mathbf{R}^{-1}\mathbf{N}^T \underline{x}(t) \end{cases} \quad (4.157)$$

The stabilizing control $u(t)$ is then defined in a similar fashion than (4.149):

$$\begin{cases} \underline{v}(t) = -\mathbf{R}^{-1}\mathbf{B}^T \mathbf{P} \underline{x}(t) \\ \underline{v}(t) = \underline{u}(t) + \mathbf{R}^{-1}\mathbf{N}^T \underline{x}(t) \end{cases} \Rightarrow \begin{cases} \underline{u}(t) = -\mathbf{K}\underline{x}(t) \\ \mathbf{K} = \mathbf{R}^{-1}(\mathbf{P}\mathbf{B} + \mathbf{N})^T \end{cases} \quad (4.158)$$

It is worth noticing that robustness properties of the LQ state feedback are lost because the cost to be minimized contains a state-control cross-term here.

Furthermore let \mathbf{V} be the change of basis matrix to the Jordan form \mathbf{A}_r of the desired closed-loop state matrix \mathbf{A}_r :

$$\mathbf{A}_r = \mathbf{V}^{-1} \mathbf{A}_r \mathbf{V} \quad (4.159)$$

Let \mathbf{A}_{cl} be the state matrix of the closed-loop which is written using matrix \mathbf{V} as follows :

$$\dot{\underline{x}}(t) = \mathbf{A}_{cl} \underline{x}(t) = \mathbf{V} \mathbf{A}_{cl} \mathbf{V}^{-1} \underline{x}(t) \quad (4.160)$$

Assuming that the desired Jordan form \mathbf{A}_r is a diagonal matrix and using the fact $\mathbf{V}^{-1} = \mathbf{V}^T$ the product $e^T(t)e(t)$ in (4.152) reads as follows:

$$\begin{aligned} \underline{e}^T(t)\underline{e}(t) &= \underline{x}^T(t) (\mathbf{A}_{cl} - \mathbf{A}_r)^T (\mathbf{A}_{cl} - \mathbf{A}_r) \underline{x}(t) \\ &= \underline{x}^T(t) \mathbf{V} (\mathbf{A}_{cl} - \mathbf{A}_r)^T (\mathbf{A}_{cl} - \mathbf{A}_r) \mathbf{V}^T \underline{x}(t) \end{aligned} \quad (4.161)$$

From the preceding equation it is clear that minimizing the cost $J(\underline{u}(t)) = \frac{1}{2} \int_0^\infty \underline{e}^T(t)\underline{e}(t) dt$ consists in finding the control $\underline{u}(t)$ which minimizes the gap between the desired eigenvalues (which are set in \mathbf{A}_r) and the actual eigenvalues of the closed-loop.

4.7 Optimal output feedback

4.7.1 Reformulation of the state feedback optimal control problem

We consider in this section the following plant:

$$\dot{\underline{x}}(t) = \mathbf{A}\underline{x}(t) + \mathbf{B}\underline{u}(t) \quad (4.162)$$

We which minimizes the following performance index J where $\mathbf{Q} = \mathbf{Q}^T \geq 0$ and $\mathbf{R} = \mathbf{R}^T > 0$:

$$J = \int_0^{\infty} (\underline{x}^T(t) \mathbf{Q} \underline{x}(t) + \underline{u}^T(t) \mathbf{R} \underline{u}(t)) dt \quad (4.163)$$

We will assume that we seek for a stabilizing static *state* feedback gain \mathbf{K} :

$$\underline{u}(t) = -\mathbf{K} \underline{x}(t) \quad (4.164)$$

Using the relation $\underline{u}(t) = -\mathbf{K} \underline{x}(t)$, the performance index J reads:

$$\begin{aligned} J &= \int_0^{\infty} (\underline{x}^T(t) \mathbf{Q} \underline{x}(t) + (\mathbf{K} \underline{x}(t))^T \mathbf{R} \mathbf{K} \underline{x}(t)) dt \\ &= \int_0^{\infty} \underline{x}^T(t) (\mathbf{Q} + \mathbf{K}^T \mathbf{R} \mathbf{K}) \underline{x}(t) dt \end{aligned} \quad (4.165)$$

Moreover, the dynamics of the plant where $\underline{u}(t) = -\mathbf{K} \underline{x}(t)$ reads:

$$\underline{u}(t) = -\mathbf{K} \underline{x}(t) \Rightarrow \dot{\underline{x}}(t) = (\mathbf{A} - \mathbf{B} \mathbf{K}) \underline{x}(t) \quad (4.166)$$

Thus, after integration, and denoting by $\underline{x}(0)$ the initial value of $\underline{x}(t)$, we get:

$$\underline{x}(t) = e^{(\mathbf{A} - \mathbf{B} \mathbf{K}) t} \underline{x}(0) \quad (4.167)$$

Consequently, the performance index J reads:

$$\begin{aligned} J &= \int_0^{\infty} \underline{x}^T(t) (\mathbf{Q} + \mathbf{K}^T \mathbf{R} \mathbf{K}) \underline{x}(t) dt \\ &= \int_0^{\infty} \underline{x}(0)^T e^{(\mathbf{A} - \mathbf{B} \mathbf{K})^T t} (\mathbf{Q} + \mathbf{K}^T \mathbf{R} \mathbf{K}) e^{(\mathbf{A} - \mathbf{B} \mathbf{K}) t} \underline{x}(0) dt \end{aligned} \quad (4.168)$$

Using the property of trace, i.e. $\text{tr}(\mathbf{XYZ}) = \text{tr}(\mathbf{YZX})$, the performance index J is written as follows:

$$\begin{aligned} J &= \int_0^{\infty} \underline{x}(0)^T e^{(\mathbf{A} - \mathbf{B} \mathbf{K})^T t} (\mathbf{Q} + \mathbf{K}^T \mathbf{R} \mathbf{K}) e^{(\mathbf{A} - \mathbf{B} \mathbf{K}) t} \underline{x}(0) dt \\ &= \text{tr} \left(\int_0^{\infty} \underline{x}(0)^T e^{(\mathbf{A} - \mathbf{B} \mathbf{K})^T t} (\mathbf{Q} + \mathbf{K}^T \mathbf{R} \mathbf{K}) e^{(\mathbf{A} - \mathbf{B} \mathbf{K}) t} \underline{x}(0) dt \right) \\ &= \text{tr} \left(\int_0^{\infty} e^{(\mathbf{A} - \mathbf{B} \mathbf{K})^T t} (\mathbf{Q} + \mathbf{K}^T \mathbf{R} \mathbf{K}) e^{(\mathbf{A} - \mathbf{B} \mathbf{K}) t} \underline{x}(0) \underline{x}(0)^T dt \right) \end{aligned} \quad (4.169)$$

Because the initial value $\underline{x}(0)$ of the state vector is usually unknown, the product $\underline{x}(0) \underline{x}(0)^T$ is removed from the performance index J . We get:

$$J = \text{tr}(\mathbf{P}) \quad (4.170)$$

where matrix \mathbf{P} is the so-called grammian:

$$\mathbf{P} = \int_0^{\infty} e^{(\mathbf{A} - \mathbf{B} \mathbf{K})^T t} (\mathbf{Q} + \mathbf{K}^T \mathbf{R} \mathbf{K}) e^{(\mathbf{A} - \mathbf{B} \mathbf{K}) t} dt = \mathbf{P}^T > 0 \quad (4.171)$$

When multiplying \mathbf{P} by $e^{(\mathbf{A} - \mathbf{B} \mathbf{K})^T t_0}$ on the left and by $e^{(\mathbf{A} - \mathbf{B} \mathbf{K}) t_0}$ on the right, we get $\forall t_0 \in \mathbb{R}$:

$$\begin{aligned} e^{(\mathbf{A} - \mathbf{B} \mathbf{K})^T t_0} \mathbf{P} e^{(\mathbf{A} - \mathbf{B} \mathbf{K}) t_0} &= \int_0^{\infty} e^{(\mathbf{A} - \mathbf{B} \mathbf{K})^T (t+t_0)} (\mathbf{Q} + \mathbf{K}^T \mathbf{R} \mathbf{K}) e^{(\mathbf{A} - \mathbf{B} \mathbf{K}) (t+t_0)} dt \\ &= \int_{t_0}^{\infty} e^{(\mathbf{A} - \mathbf{B} \mathbf{K})^T t} (\mathbf{Q} + \mathbf{K}^T \mathbf{R} \mathbf{K}) e^{(\mathbf{A} - \mathbf{B} \mathbf{K}) t} dt \end{aligned} \quad (4.172)$$

Differentiation with respect to t_0 and using the facts that matrix $\mathbf{A} - \mathbf{BK}$ is assumed to be stable (that is $\lim_{t \rightarrow \infty} e^{(\mathbf{A} - \mathbf{BK})t} = \lim_{t \rightarrow \infty} e^{(\mathbf{A} - \mathbf{BK})^T t} = \mathbf{0}$) and that $g(x) = \int_{a(x)}^{b(x)} f(\tau) d\tau \Rightarrow g'(x) = f(b(x))b'(x) - f(a(x))a'(x)$ yields:

$$\begin{aligned} & (\mathbf{A} - \mathbf{BK})^T e^{(\mathbf{A} - \mathbf{BK})^T t_0} \mathbf{P} e^{(\mathbf{A} - \mathbf{BK}) t_0} \\ & \quad + e^{(\mathbf{A} - \mathbf{BK})^T t_0} \mathbf{P} e^{(\mathbf{A} - \mathbf{BK}) t_0} (\mathbf{A} - \mathbf{BK}) \\ & \quad = -e^{(\mathbf{A} - \mathbf{BK})^T t_0} (\mathbf{Q} + \mathbf{K}^T \mathbf{R} \mathbf{K}) e^{(\mathbf{A} - \mathbf{BK}) t_0} \end{aligned} \quad (4.173)$$

Finally setting $t_0 = 0$ leads to the following Lyapunov equation:

$$(\mathbf{A} - \mathbf{BK})^T \mathbf{P} + \mathbf{P} (\mathbf{A} - \mathbf{BK}) = -(\mathbf{Q} + \mathbf{K}^T \mathbf{R} \mathbf{K}) \quad (4.174)$$

Alternatively, and following Lewis & al.¹⁰, assume that there exists a positive definite matrix $\mathbf{P} = \mathbf{P}^T > 0$ such that the following equality holds:

$$\frac{d}{dt} (\underline{x}^T(t) \mathbf{P} \underline{x}(t)) = -\underline{x}^T(t) (\mathbf{Q} + \mathbf{K}^T \mathbf{R} \mathbf{K}) \underline{x}(t) \quad (4.175)$$

Then the performance index J defined in (4.165) reads:

$$\begin{aligned} J &= \int_0^\infty \underline{x}^T(t) (\mathbf{Q} + \mathbf{K}^T \mathbf{R} \mathbf{K}) \underline{x}(t) dt \\ &= - \int_0^\infty \frac{d}{dt} (\underline{x}^T(t) \mathbf{P} \underline{x}(t)) dt \\ &= - \underline{x}^T(t) \mathbf{P} \underline{x}(t) \Big|_{t=0}^{t \rightarrow \infty} \\ &= \underline{x}^T(0) \mathbf{P} \underline{x}(0) - \lim_{t \rightarrow \infty} \underline{x}^T(t) \mathbf{P} \underline{x}(t) \end{aligned} \quad (4.176)$$

Assuming that the closed-loop is stable so that $\underline{x}(t)$ vanishes with time, we get the following relation where $\text{tr}(\mathbf{X})$ denotes the trace of matrix \mathbf{X} :

$$\lim_{t \rightarrow \infty} \underline{x}(t) = \underline{0} \Rightarrow J = \underline{x}^T(0) \mathbf{P} \underline{x}(0) = \text{tr}(\mathbf{P} \underline{x}(0) \underline{x}^T(0)) \quad (4.177)$$

Furthermore, when using (4.162) and (4.163) in (4.175), we can write:

$$\begin{aligned} -\underline{x}^T(t) (\mathbf{Q} + \mathbf{K}^T \mathbf{R} \mathbf{K}) \underline{x}(t) &= \frac{d}{dt} (\underline{x}^T(t) \mathbf{P} \underline{x}(t)) \\ &= \dot{\underline{x}}^T(t) \mathbf{P} \underline{x}(t) + \underline{x}^T(t) \mathbf{P} \dot{\underline{x}}(t) \\ &= (\mathbf{A} \underline{x}(t) + \mathbf{B} \underline{u}(t))^T \mathbf{P} \underline{x}(t) + \underline{x}^T(t) \mathbf{P} (\mathbf{A} \underline{x}(t) + \mathbf{B} \underline{u}(t)) \\ &= ((\mathbf{A} - \mathbf{BK}) \underline{x}(t))^T \mathbf{P} \underline{x}(t) + \underline{x}^T(t) \mathbf{P} ((\mathbf{A} - \mathbf{BK}) \underline{x}(t)) \\ &= \underline{x}^T(t) \left((\mathbf{A} - \mathbf{BK})^T \mathbf{P} + \mathbf{P} (\mathbf{A} - \mathbf{BK}) \right) \underline{x}(t) \end{aligned} \quad (4.178)$$

Since this relation shall hold for all value of $\underline{x}(t)$, we shall have:

$$-(\mathbf{Q} + \mathbf{K}^T \mathbf{R} \mathbf{K}) = (\mathbf{A} - \mathbf{BK})^T \mathbf{P} + \mathbf{P} (\mathbf{A} - \mathbf{BK}) \quad (4.179)$$

We retrieve the Lyapunov equation (4.174).

Consequently, the *dynamic* optimization control problem can be converted into the following equivalent *static* optimization control problem:

<p>Find $\mathbf{P} = \mathbf{P}^T > 0$ and \mathbf{K} which minimizes $\text{tr}(\mathbf{P})$ under the constraint $\mathbf{A}_{cl}^T \mathbf{P} + \mathbf{P} \mathbf{A}_{cl} + (\mathbf{Q} + \mathbf{K}^T \mathbf{R} \mathbf{K}) = \mathbf{0}$ where $\mathbf{A}_{cl} := \mathbf{A} - \mathbf{BK}$</p>	(4.180)
---	---------

¹⁰Lewis F., Vrabie D., Syrmos V., Optimal Control, John Wiley & Sons, 3rd Edition, 2012

The constraint to be satisfied is simply the algebraic Riccati equation. Indeed by adding and subtracting terms \mathbf{PBK} and $(\mathbf{BK})^T \mathbf{P}$ within the algebraic Riccati equation we get:

$$\begin{aligned}
& \mathbf{A}^T \mathbf{P} + \mathbf{P} \mathbf{A} - \mathbf{P} \mathbf{B} \mathbf{R}^{-1} \mathbf{B}^T \mathbf{P} + \mathbf{Q} = \mathbf{0} \\
& \Leftrightarrow (\mathbf{A} - \mathbf{BK})^T \mathbf{P} + \mathbf{P} (\mathbf{A} - \mathbf{BK}) + (\mathbf{BK})^T \mathbf{P} + \mathbf{PBK} - \mathbf{P} \mathbf{B} \mathbf{R}^{-1} \mathbf{B}^T \mathbf{P} + \mathbf{Q} = \mathbf{0} \\
& \Leftrightarrow (\mathbf{A} - \mathbf{BK})^T \mathbf{P} + \mathbf{P} (\mathbf{A} - \mathbf{BK}) + \mathbf{K}^T \mathbf{B}^T \mathbf{P} + \mathbf{PBK} - \mathbf{P} \mathbf{B} \mathbf{R}^{-1} \mathbf{B}^T \mathbf{P} + \mathbf{Q} = \mathbf{0} \\
& \mathbf{K} = \mathbf{R}^{-1} \mathbf{B}^T \mathbf{P} \Rightarrow (\mathbf{A} - \mathbf{BK})^T \mathbf{P} + \mathbf{P} (\mathbf{A} - \mathbf{BK}) + \mathbf{K}^T \mathbf{B}^T \mathbf{P} + \mathbf{PBK} - \mathbf{PBK} + \mathbf{Q} = \mathbf{0} \\
& \mathbf{B}^T \mathbf{P} = \mathbf{RK} \Rightarrow (\mathbf{A} - \mathbf{BK})^T \mathbf{P} + \mathbf{P} (\mathbf{A} - \mathbf{BK}) + (\mathbf{Q} + \mathbf{K}^T \mathbf{RK}) = \mathbf{0}
\end{aligned} \tag{4.181}$$

4.7.2 Output feedback optimal control problem

The preceding result can be extended to *output* feedback optimal control problem. Indeed, consider the following plant:

$$\begin{cases} \dot{\underline{x}}(t) = \mathbf{A} \underline{x}(t) + \mathbf{B} \underline{u}(t) \\ \underline{y}(t) = \mathbf{C} \underline{x}(t) \end{cases} \tag{4.182}$$

We wish to find a stabilizing static *output* feedback gain \mathbf{K} , $\underline{u}(t) = -\mathbf{K} \underline{y}(t)$, which minimizes the following performance index J where $\mathbf{Q} = \mathbf{Q}^T \geq 0$ and $\mathbf{R} = \mathbf{R}^T > 0$:

$$\begin{cases} J = \int_0^\infty (\underline{x}^T(t) \mathbf{Q} \underline{x}(t) + \underline{u}^T(t) \mathbf{R} \underline{u}(t)) dt \\ \underline{u}(t) = -\mathbf{K} \underline{y}(t) = -\mathbf{K} \mathbf{C} \underline{x}(t) \end{cases} \tag{4.183}$$

Let:

$$\boxed{\mathbf{Q}_K = \mathbf{Q} + \mathbf{C}^T \mathbf{K}^T \mathbf{R} \mathbf{K} \mathbf{C} = \mathbf{Q}_K^T \geq 0} \tag{4.184}$$

Then the performance index J reads:

$$\begin{aligned}
J &= \int_0^\infty (\underline{x}^T(t) \mathbf{Q} \underline{x}(t) + (\mathbf{K} \mathbf{C} \underline{x}(t))^T \mathbf{R} \mathbf{K} \mathbf{C} \underline{x}(t)) dt \\
&= \int_0^\infty \underline{x}^T(t) (\mathbf{Q} + \mathbf{C}^T \mathbf{K}^T \mathbf{R} \mathbf{K} \mathbf{C}) \underline{x}(t) dt \\
&= \int_0^\infty \underline{x}^T(t) \mathbf{Q}_K \underline{x}(t) dt
\end{aligned} \tag{4.185}$$

Following Lewis & al.¹⁰, assume that there exists a positive definite matrix $\mathbf{P} = \mathbf{P}^T > 0$ such that the following equality holds:

$$\frac{d}{dt} (\underline{x}^T(t) \mathbf{P} \underline{x}(t)) = -\underline{x}^T(t) \mathbf{Q}_K \underline{x}(t) \tag{4.186}$$

The performance index J now reads:

$$\begin{aligned}
J &= - \int_0^\infty \frac{d}{dt} (\underline{x}^T(t) \mathbf{P} \underline{x}(t)) dt \\
&= - \underline{x}^T(t) \mathbf{P} \underline{x}(t) \Big|_{t=0}^{t \rightarrow \infty} \\
&= \underline{x}^T(0) \mathbf{P} \underline{x}(0) - \lim_{t \rightarrow \infty} \underline{x}^T(t) \mathbf{P} \underline{x}(t)
\end{aligned} \tag{4.187}$$

Assuming that the closed-loop is stable so that $\underline{x}(t)$ vanishes with time, we get the following relation where $\text{tr}(\mathbf{X})$ denotes the trace of matrix \mathbf{X} :

$$\lim_{t \rightarrow \infty} \underline{x}(t) = \underline{0} \Rightarrow J = \underline{x}^T(0) \mathbf{P} \underline{x}(0) = \text{tr}(\mathbf{P} \underline{x}(0) \underline{x}^T(0)) \tag{4.188}$$

Furthermore, when using (4.182) and (4.183) in (4.186), we can write:

$$\begin{aligned}
-\underline{x}^T(t) \mathbf{Q}_K \underline{x}(t) &= \frac{d}{dt} (\underline{x}^T(t) \mathbf{P} \underline{x}(t)) \\
&= \dot{\underline{x}}^T(t) \mathbf{P} \underline{x}(t) + \underline{x}^T(t) \mathbf{P} \dot{\underline{x}}(t) \\
&= (\mathbf{A} \underline{x}(t) + \mathbf{B} u(t))^T \mathbf{P} \underline{x}(t) + \underline{x}^T(t) \mathbf{P} (\mathbf{A} \underline{x}(t) + \mathbf{B} u(t)) \\
&= ((\mathbf{A} - \mathbf{B} \mathbf{K} \mathbf{C}) \underline{x}(t))^T \mathbf{P} \underline{x}(t) + \underline{x}^T(t) \mathbf{P} ((\mathbf{A} - \mathbf{B} \mathbf{K} \mathbf{C}) \underline{x}(t)) \\
&= \underline{x}^T(t) \left((\mathbf{A} - \mathbf{B} \mathbf{K} \mathbf{C})^T \mathbf{P} + \mathbf{P} (\mathbf{A} - \mathbf{B} \mathbf{K} \mathbf{C}) \right) \underline{x}(t)
\end{aligned} \tag{4.189}$$

Since this relation shall hold for all value of $\underline{x}(t)$, we shall have:

$$-\mathbf{Q}_K = (\mathbf{A} - \mathbf{B} \mathbf{K} \mathbf{C})^T \mathbf{P} + \mathbf{P} (\mathbf{A} - \mathbf{B} \mathbf{K} \mathbf{C}) \tag{4.190}$$

Consequently, the *dynamical* optimization control problem can be converted into the following equivalent *static* optimization control problem:

<p>Find $\mathbf{P} = \mathbf{P}^T > 0$ and \mathbf{K} which minimizes $\text{tr}(\mathbf{P})$ under the constraint $(\mathbf{A} - \mathbf{B} \mathbf{K} \mathbf{C})^T \mathbf{P} + \mathbf{P} (\mathbf{A} - \mathbf{B} \mathbf{K} \mathbf{C}) + \mathbf{Q}_K = \mathbf{0}$</p>	(4.191)
--	---------

4.7.3 Solution of the output feedback optimal control problem

First, we recall the following property: let $\mathbf{X} \mathbf{Y} \mathbf{Z}$ be a square matrix where matrices \mathbf{X} , \mathbf{Y} and \mathbf{Z} are of appropriate dimension. Then the following properties hold¹⁰:

$$\left\{ \begin{array}{l} \frac{\partial \text{tr}(\mathbf{X} \mathbf{Y})}{\partial \mathbf{Y}} = \mathbf{X}^T \\ \frac{\partial \text{tr}(\mathbf{X} \mathbf{Y} \mathbf{Z})}{\partial \mathbf{Y}} = \mathbf{X}^T \mathbf{Z}^T \\ \frac{\partial \text{tr}(\mathbf{X} \mathbf{Y}^T \mathbf{Z})}{\partial \mathbf{Y}} = \frac{\partial \text{tr}(\mathbf{Z}^T \mathbf{Y} \mathbf{X}^T)}{\partial \mathbf{Y}} = \mathbf{Z} \mathbf{X} \end{array} \right. \tag{4.192}$$

Example 4.2. In order to illustrate the first relation, we consider the following matrices:

$$\left\{ \begin{array}{l} \mathbf{X} = \begin{bmatrix} 2 & 3 \\ 4 & 5 \end{bmatrix} \\ \mathbf{Y} = \begin{bmatrix} y_{11} & y_{12} \\ y_{21} & y_{22} \end{bmatrix} \end{array} \right. \tag{4.193}$$

Then:

$$\begin{aligned}
\text{tr}(\mathbf{X} \mathbf{Y}) &= \begin{bmatrix} 2 & 3 \\ 4 & 5 \end{bmatrix} \begin{bmatrix} y_{11} & y_{12} \\ y_{21} & y_{22} \end{bmatrix} = \begin{bmatrix} 2y_{11} + 3y_{21} & 2y_{12} + 3y_{22} \\ 4y_{11} + 5y_{21} & 4y_{12} + 5y_{22} \end{bmatrix} \\
\Rightarrow \text{tr}(\mathbf{X} \mathbf{Y}) &= 2y_{11} + 3y_{21} + 4y_{12} + 5y_{22}
\end{aligned} \tag{4.194}$$

Thus:

$$\frac{\partial \text{tr}(\mathbf{X} \mathbf{Y})}{\partial \mathbf{Y}} = \begin{bmatrix} \frac{\partial \text{tr}(\mathbf{X} \mathbf{Y})}{\partial y_{11}} & \frac{\partial \text{tr}(\mathbf{X} \mathbf{Y})}{\partial y_{12}} \\ \frac{\partial \text{tr}(\mathbf{X} \mathbf{Y})}{\partial y_{21}} & \frac{\partial \text{tr}(\mathbf{X} \mathbf{Y})}{\partial y_{22}} \end{bmatrix} = \begin{bmatrix} 2 & 4 \\ 3 & 5 \end{bmatrix} = \mathbf{X}^T \tag{4.195}$$

■

Now, we are in position to solve the output feedback optimal control problem thanks to the Lagrange multiplier approach. We define the (scalar) Hamiltonian \mathcal{H} as follows where $\mathbf{\Lambda} = \mathbf{\Lambda}^T$ is a $n \times n$ diagonal matrix of Lagrange multipliers to be determined:

$$\mathcal{H} = \text{tr}(\mathbf{P}) + \text{tr} \left(\mathbf{\Lambda} \left((\mathbf{A} - \mathbf{BKC})^T \mathbf{P} + \mathbf{P} (\mathbf{A} - \mathbf{BKC}) + \mathbf{Q}_K \right) \right) \quad (4.196)$$

The necessary conditions to solve this optimization problem with respect to matrices \mathbf{K} , $\mathbf{\Lambda}$ and \mathbf{P} read as follows:

$$\begin{cases} \frac{\partial \mathcal{H}}{\partial \mathbf{K}} = \mathbf{0} \Rightarrow 2(\mathbf{RKCAC}^T - \mathbf{B}^T \mathbf{P} \mathbf{A} \mathbf{C}^T) = \mathbf{0} \\ \frac{\partial \mathcal{H}}{\partial \mathbf{\Lambda}} = \mathbf{0} \Rightarrow (\mathbf{A} - \mathbf{BKC})^T \mathbf{P} + \mathbf{P} (\mathbf{A} - \mathbf{BKC}) + \mathbf{Q}_K = \mathbf{0} \\ \frac{\partial \mathcal{H}}{\partial \mathbf{P}} = \mathbf{0} \Rightarrow \mathbb{I} + (\mathbf{A} - \mathbf{BKC})^T \mathbf{\Lambda} + \mathbf{\Lambda} (\mathbf{A} - \mathbf{BKC}) = \mathbf{0} \end{cases} \quad (4.197)$$

From the first equation, and assuming that \mathbf{CAC}^T is nonsingular, the static *output* feedback gain \mathbf{K} can be computed as a function of Lagrange multipliers $\mathbf{\Lambda}$:

$$\frac{\partial \mathcal{H}}{\partial \mathbf{K}} = \mathbf{0} \Rightarrow \mathbf{K} = \mathbf{R}^{-1} \mathbf{B}^T \mathbf{P} \mathbf{A} \mathbf{C}^T (\mathbf{C} \mathbf{A} \mathbf{C}^T)^{-1} \quad (4.198)$$

It is worth noticing that for the static *state* feedback case where $\mathbf{C} = \mathbb{I}$, the static *state* feedback \mathbf{K} no more depends of Lagrange multipliers $\mathbf{\Lambda}$:

$$\mathbf{C} = \mathbb{I} \Rightarrow \mathbf{K} = \mathbf{R}^{-1} \mathbf{B}^T \mathbf{P} \quad (4.199)$$

Moreover, in the *state* feedback case the Lyapunov equation specifying the constraint turns to be the algebraic Riccati equation:

$$\begin{aligned} \mathbf{C} = \mathbb{I} &\Rightarrow \mathbf{K} = \mathbf{R}^{-1} \mathbf{B}^T \mathbf{P} \Rightarrow \mathbf{Q}_K = \mathbf{Q} + \mathbf{K}^T \mathbf{R} \mathbf{K} = \mathbf{Q} + \mathbf{P} \mathbf{B} \mathbf{R}^{-1} \mathbf{B}^T \mathbf{P} \\ \Rightarrow \mathbf{0} &= (\mathbf{A} - \mathbf{BKC})^T \mathbf{P} + \mathbf{P} (\mathbf{A} - \mathbf{BKC}) + \mathbf{Q}_K \\ &= (\mathbf{A} - \mathbf{BK})^T \mathbf{P} + \mathbf{P} (\mathbf{A} - \mathbf{BK}) + \mathbf{Q} + \mathbf{P} \mathbf{B} \mathbf{R}^{-1} \mathbf{B}^T \mathbf{P} \\ &= \mathbf{A}^T \mathbf{P} + \mathbf{P} \mathbf{A} - \mathbf{P} \mathbf{B} \mathbf{R}^{-1} \mathbf{B}^T \mathbf{P} + \mathbf{Q} \end{aligned} \quad (4.200)$$

4.7.4 Poles placement in a specified region

In this section, we still wish to find a stabilizing static *output* feedback gain \mathbf{K} , $\underline{u}(t) = -\mathbf{K}\underline{y}(t)$, which minimizes the performance index J defined in (4.183). We add the constraint that closed-loop poles are situated in the sector region $C(\alpha, \theta)$ shown in Figure 4.3.

Let \mathbf{Q}_K be defined as in (4.184) and let \mathbf{A}_{cl} be the closed-loop state matrix:

$$\mathbf{A}_{cl} = \mathbf{A} - \mathbf{BKC} \quad (4.201)$$

We have seen in the previous section that if there exists a positive definite matrix $\mathbf{P} = \mathbf{P}^T > 0$ such that the following equality holds:

$$\mathbf{A}_{cl}^T \mathbf{P} + \mathbf{P} \mathbf{A}_{cl} + \mathbf{Q}_K = \mathbf{0} \quad (4.202)$$

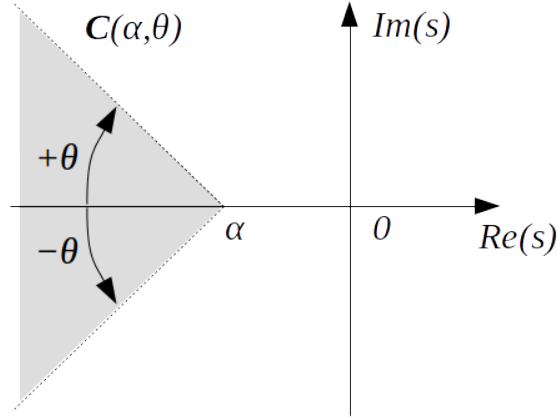
Figure 4.3: Sector region $C(\alpha, \theta)$

Then the minimum cost J^* reads as follows where $\text{tr}(\mathbf{X})$ denotes the trace of matrix \mathbf{X} :

$$J^* = \underline{x}^T(0) \mathbf{P} \underline{x}(0) = \text{tr}(\mathbf{P} \underline{x}(0) \underline{x}^T(0)) \quad (4.203)$$

Following Yuan & al.¹¹, let matrix $\tilde{\mathbf{A}}$ be defined as follows, where \otimes denotes the Kronecker product:

$$\begin{cases} \mathbf{A}_\alpha = \mathbf{A} - \alpha \mathbb{I} & \text{where } \alpha \leq 0 \\ \tilde{\mathbf{A}} = \begin{bmatrix} \sin(\theta) \mathbf{A}_\alpha & \cos(\theta) \mathbf{A}_\alpha \\ -\cos(\theta) \mathbf{A}_\alpha & \sin(\theta) \mathbf{A}_\alpha \end{bmatrix} := \begin{bmatrix} \sin(\theta) & \cos(\theta) \\ -\cos(\theta) & \sin(\theta) \end{bmatrix} \otimes \mathbf{A}_\alpha \end{cases} \quad (4.204)$$

Then it can be shown¹¹ that all the eigenvalues of matrix \mathbf{A} will be situated inside the sector region $C(\alpha, \theta)$ shown in Figure 4.3 if and only if all the eigenvalues of matrix $\tilde{\mathbf{A}}$ are situated in the left half plane. Denoting by $\Psi(s)$ the polynomial whose companion matrix is $\tilde{\mathbf{A}}$, this can be tested for example with the Routh-Hurwitz criterion.

This result can be extended to the case where we add the constraint that all the eigenvalues of state matrix \mathbf{A} shall have a real part greater than α_m . This will be the case if and only if all the eigenvalues of the following block diagonal matrix $\tilde{\mathbf{A}}_e$ are situated in the left half plane:

$$\tilde{\mathbf{A}}_e = \begin{bmatrix} \tilde{\mathbf{A}} & \mathbf{0} \\ \mathbf{0} & \alpha_m \mathbb{I} - \mathbf{A} \end{bmatrix} \quad (4.205)$$

Moreover let:

$$\begin{cases} \begin{bmatrix} \tilde{\mathbf{B}}_1 & \tilde{\mathbf{B}}_2 \end{bmatrix} := \begin{bmatrix} \sin(\theta) & \cos(\theta) \\ -\cos(\theta) & \sin(\theta) \end{bmatrix} \otimes \mathbf{B} \\ \tilde{\mathbf{A}}_{cl} = \tilde{\mathbf{A}} - \begin{bmatrix} \tilde{\mathbf{B}}_1 & \tilde{\mathbf{B}}_2 \end{bmatrix} \mathbf{K} \mathbf{C} \end{cases} \quad (4.206)$$

¹¹Yuan L., Achenie L., Jiang W., Linear Quadratic Optimal Output Feedback Control For Systems With Poles In A Specified Region, International Journal of Control, Vol. 64(6), pages = 1151-1164, 1996

Then the optimal control problem for poles placement in a specified region reads as follows¹¹:

$$\begin{aligned} & \text{Find } \mathbf{P} = \mathbf{P}^T > 0 \text{ and } \mathbf{K} \\ & \text{which minimize } \text{tr}(\mathbf{P}) \text{ under the constraints :} \\ & \begin{cases} (\mathbf{A} - \mathbf{BKC})^T \mathbf{P} + \mathbf{P}(\mathbf{A} - \mathbf{BKC}) + \mathbf{Q}_K = \mathbf{0} \\ \tilde{\mathbf{A}}_{cl}^T \mathbf{P} + \mathbf{P} \tilde{\mathbf{A}}_{cl} < 0 \end{cases} \end{aligned} \quad (4.207)$$

where:

$$\tilde{\mathbf{A}}_{cl} = \begin{bmatrix} \sin(\theta) & \cos(\theta) \\ -\cos(\theta) & \sin(\theta) \end{bmatrix} \otimes (\mathbf{A} - \alpha \mathbb{I} - \mathbf{BKC}) \quad (4.208)$$

4.8 Frequency shaped LQ control

Often system performances are specified in the frequency domain. The purpose of this section is to shift the time domain nature of the LQR problem in the frequency domain as proposed by Gupta in 1980¹². This is done thanks to Parseval's theorem which enables to write the performance index J to be minimized as follows, where w represents frequency (in *rad/sec*):

$$\begin{aligned} J &= \int_0^\infty (\underline{x}^T(t) \mathbf{Q} \underline{x}(t) + u^T(t) \mathbf{R} u(t)) dt \\ &= \frac{1}{2\pi} \int_0^\infty \underline{x}^T(-j\omega) \mathbf{Q} \underline{x}(j\omega) + u^T(-j\omega) \mathbf{R} u(j\omega) d\omega \end{aligned} \quad (4.209)$$

Then constant weighting matrices \mathbf{Q} and \mathbf{R} are modified to be function of the frequency w in order to place distinct penalties on the state and control cost at various frequencies:

$$\begin{cases} \mathbf{Q} = \mathbf{Q}(w) = \mathbf{W}_q^T(-j\omega) \mathbf{W}_q(j\omega) \\ \mathbf{R} = \mathbf{R}(w) = \mathbf{W}_r^T(-j\omega) \mathbf{W}_r(j\omega) \end{cases} \quad (4.210)$$

For the existence of the solution of the LQ regulator, matrix $\mathbf{R}(w)$ shall be of full rank. Since we seek to minimize the quadratic cost J , then large terms in the integrand incur greater penalties than small terms and more effort is exerted to make them small. Thus if there is for example an high frequency region where the model of the plant presents unmodeled dynamics and if the control weight $\mathbf{W}_r(j\omega)$ is chosen to have large magnitude over this region then the resulting controller would not exert substantial energy in this region. This in turn would limit the controller bandwidth.

Let us define the following vectors to carry out the dynamics of the weights in the frequency domain, where s denotes the Laplace variable:

$$\begin{cases} \underline{z}(s) = \mathbf{W}_q(s) \underline{x}(s) \\ v(s) = \mathbf{W}_r(s) u(s) \end{cases} \quad (4.211)$$

In order to simplify the process of selecting useful weights, it is common to choose weighting matrices to be scalar functions multiplying the identity matrix:

$$\begin{cases} \mathbf{W}_q(s) = w_q(s) \mathbb{I} \\ \mathbf{W}_r(s) = w_r(s) \mathbb{I} \end{cases} \quad (4.212)$$

¹²Frequency-Shaped Cost Functionals: Extension of Linear Quadratic Gaussian Design Methods, Narendra K. Gupta, Journal of Guidance Control and Dynamics. 11/1980; 3(6):529-535. DOI: 10.2514/3.19722

The performance index J to be minimized in (4.209) turns to be:

$$J = \frac{1}{2\pi} \int_0^\infty \underline{z}^T(-j\omega)\underline{z}(j\omega) + v^T(-j\omega)v(j\omega) d\omega \quad (4.213)$$

Using Parseval's theorem we get in the time domain:

$$J = \int_0^\infty \underline{z}^T(t)\underline{z}(t) + v^T(t)v(t) dt \quad (4.214)$$

Let the state space model of the first equation of (4.211) be the following, where $\underline{z}(t)$ is the output and $\underline{x}(t)$ the input of the following MIMO system:

$$\begin{cases} \dot{\chi}_q(t) = \mathbf{A}_q\chi_q(t) + \mathbf{B}_q\underline{x}(t) \\ \underline{z}(t) = \mathbf{N}_q\chi_q(t) + \mathbf{D}_q\underline{x}(t) \end{cases} \quad (4.215)$$

$$\Rightarrow \underline{z}(s) = \left(\mathbf{N}_q(sI - \mathbf{A}_q)^{-1}\mathbf{B}_q + \mathbf{D}_q \right) \underline{x}(s) = \mathbf{W}_q(s)\underline{x}(s)$$

Similarly, let the state space model of the second equation of (4.211) be the following, where $v(t)$ is the output and $u(t)$ the input of the following MIMO system:

$$\begin{cases} \dot{\chi}_r(t) = \mathbf{A}_r\chi_r(t) + \mathbf{B}_ru(t) \\ v(t) = \mathbf{N}_r\chi_r(t) + \mathbf{D}_ru(t) \end{cases} \quad (4.216)$$

$$\Rightarrow v(s) = \left(\mathbf{N}_r(sI - \mathbf{A}_r)^{-1}\mathbf{B}_r + \mathbf{D}_r \right) u(s) = \mathbf{W}_r(s)u(s)$$

Then it can be shown from (4.215) and (4.216) that:

$$\begin{aligned} \underline{z}^T(t)\underline{z}(t) + v^T(t)v(t) &= (\mathbf{N}_q\chi_q(t) + \mathbf{D}_q\underline{x}(t))^T (\mathbf{N}_q\chi_q(t) + \mathbf{D}_q\underline{x}(t)) \\ &\quad + (\mathbf{N}_r\chi_r(t) + \mathbf{D}_ru(t))^T (\mathbf{N}_r\chi_r(t) + \mathbf{D}_ru(t)) \end{aligned} \quad (4.217)$$

That is:

$$\begin{aligned} \underline{z}^T(t)\underline{z}(t) + v^T(t)v(t) &= \begin{bmatrix} \underline{x}^T(t) & \chi_q^T(t) & \chi_r(t)^T \end{bmatrix} \mathbf{Q}_f \begin{bmatrix} \underline{x}(t) \\ \chi_q(t) \\ \chi_r(t) \end{bmatrix} \\ &\quad + 2 \begin{bmatrix} \underline{x}^T(t) & \chi_q^T(t) & \chi_r(t)^T \end{bmatrix} \mathbf{N}_f u(t) + u^T(t)\mathbf{R}_f u(t) \end{aligned} \quad (4.218)$$

Where:

$$\left\{ \begin{array}{l} \mathbf{Q}_f = \begin{bmatrix} \mathbf{D}_q^T\mathbf{D}_q & \mathbf{D}_q^T\mathbf{N}_q & 0 \\ \mathbf{N}_q^T\mathbf{D}_q & \mathbf{N}_q^T\mathbf{N}_q & 0 \\ 0 & 0 & \mathbf{N}_r^T\mathbf{N}_r \end{bmatrix} \\ \mathbf{N}_f = \begin{bmatrix} 0 \\ 0 \\ \mathbf{N}_r^T\mathbf{D}_r \end{bmatrix} \\ \mathbf{R}_f = \mathbf{D}_r^T\mathbf{D}_r \end{array} \right. \quad (4.219)$$

Then define the augmented state vector $\underline{x}_a(t)$:

$$\underline{x}_a(t) = \begin{bmatrix} \underline{x}(t) \\ \chi_q(t) \\ \chi_r(t) \end{bmatrix} \quad (4.220)$$

And the augmented state space model:

$$\dot{\underline{x}}_a(t) = \frac{d}{dt} \begin{bmatrix} \underline{x}(t) \\ \chi_q(t) \\ \chi_r(t) \end{bmatrix} = \mathbf{A}_a \underline{x}_a(t) + \mathbf{B}_a u(t) \quad (4.221)$$

Where:

$$\begin{cases} \mathbf{A}_a = \begin{bmatrix} \mathbf{A} & 0 & 0 \\ \mathbf{B}_q & \mathbf{A}_q & 0 \\ 0 & 0 & \mathbf{A}_r \end{bmatrix} \\ \mathbf{B}_a = \begin{bmatrix} \mathbf{B} \\ 0 \\ \mathbf{B}_r \end{bmatrix} \end{cases} \quad (4.222)$$

Using (4.218) the performance index J defined in (4.214) is written as follows:

$$J = \int_0^\infty \underline{x}_a^T(t) \mathbf{Q}_f \underline{x}_a(t) + 2 \underline{x}_a(t) \mathbf{N}_f u(t) + u(t)^T \mathbf{R}_f u(t) dt \quad (4.223)$$

As far as cross-term in the performance index J appears results obtained in section 4.6.1 will be used: The algebraic Riccati equation (4.150) reads as follows:

$$\mathbf{P} \mathbf{A}_m + \mathbf{A}_m^T \mathbf{P} - \mathbf{P} \mathbf{B}_a \mathbf{R}^{-1} \mathbf{B}_a^T \mathbf{P} + \mathbf{Q}_m = \mathbf{0} \quad (4.224)$$

Where:

$$\begin{cases} \mathbf{Q}_m = \mathbf{Q}_f - \mathbf{N}_f \mathbf{R}_f^{-1} \mathbf{N}_f^T \\ \mathbf{A}_m = \mathbf{A}_a - \mathbf{B}_a \mathbf{R}_f^{-1} \mathbf{N}_f^T \end{cases} \quad (4.225)$$

Denoting by \mathbf{P} the positive definite matrix which solves the *algebraic Riccati* equation (4.224), the stabilizing control $u(t)$ is then defined in a similar fashion than (4.149):

$$\begin{cases} u(t) = -\mathbf{K} \underline{x}(t) \\ \mathbf{K} = \mathbf{R}_f^{-1} (\mathbf{P} \mathbf{B}_a + \mathbf{N}_f)^T \end{cases} \quad (4.226)$$

4.9 Optimal transient stabilization

We provide in that section the material written by L. Qiu and K. Zhou¹³. Let's consider the feedback system for stabilization system in Figure 4.4 where $F(s)$ is the plant and $K(s)$ is the controller: The known transfer function $F(s)$ of the plant is assumed to be strictly proper with a *monic polynomial* on the denominator (a *monic polynomial* is a polynomial in which the leading coefficient (the nonzero coefficient of highest degree) is equal to 1):

$$F(s) = \frac{N(s)}{D(s)} = \frac{b_{n-1}s^{n-1} + \dots + b_1s + b_0}{s^n + a_{n-1}s^{n-1} + \dots + a_1s + a_0} \quad (4.227)$$

¹³Preclassical Tools for Postmodern Control, An optimal And Robust Control Theory For Undergraduate Education, Li Qiu and Kemin Zhou, IEEE Control Systems Magazine, August 2013

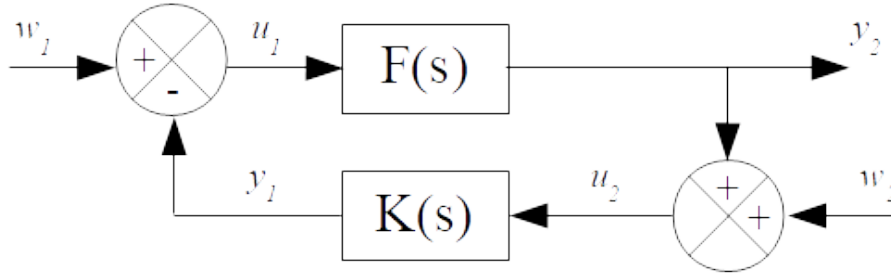

Figure 4.4: Feedback system for stabilization

Similarly the unknown transfer function $K(s)$ of the controller is assumed to be strictly proper with a monic polynomial on the denominator:

$$K(s) = \frac{q(s)}{p(s)} = \frac{q_{m-1}s^{m-1} + \cdots + q_1s + q_0}{s^m + p_{m-1}s^{m-1} + \cdots + p_1s + p_0} \quad (4.228)$$

The closed-loop characteristic polynomial $\beta(s)$ is:

$$\begin{aligned} \beta(s) &= N(s)q(s) + D(s)p(s) \\ &= s^{n+m} + \beta_{n+m-1}s^{n+m-1} + \cdots + \beta_1s + \beta_0 \end{aligned} \quad (4.229)$$

For given coprime polynomials $N(s)$ and $D(s)$ as well as an arbitrarily chosen closed-loop characteristic polynomial $\beta(s)$ the expression of $p(s)$ and $q(s)$ amounts to solving the following Diophantine equation:

$$\beta(s) = N(s)q(s) + D(s)p(s) \quad (4.230)$$

This linear equation in the coefficients of $p(s)$ and $q(s)$ has solution for arbitrary $\beta(s)$ if and only if $m \geq n$. The solution is unique if and only if $m = n$. Now consider the following performance measure $J(\rho, \mu)$ where ρ and μ are positive number to give relative weights to outputs $y_1(t)$ and $y_2(t)$ and to inputs $w_1(t)$ and $w_2(t)$ respectively and $\delta(t)$ is the Dirac delta function:

$$\begin{aligned} J(\rho, \mu) &= \frac{1}{2} \int_0^\infty y_1^2(t) + \rho y_2^2(t) dt \Bigg|_{\substack{w_1(t) = \mu\delta(t) \\ w_2(t) = 0}} \\ &\quad + \frac{1}{2} \int_0^\infty y_1^2(t) + \rho y_2^2(t) dt \Bigg|_{\substack{w_1(t) = 0 \\ w_2(t) = \delta(t)}} \end{aligned} \quad (4.231)$$

The design procedure to obtain the controller which minimizes performance measure $J(\rho, \mu)$ is the following:

- Find polynomial $d_\mu(s)$ (also called *spectral factor*) which is formed with the n roots with negative real parts of $D(s)D(-s) + \mu^2N(s)N(-s)$:

$$D(s)D(-s) + \mu^2N(s)N(-s) = d_\mu(s)d_\mu(-s) \quad (4.232)$$

- Find polynomial $d_\rho(s)$ (also called *spectral factor*) which is formed with the n roots with negative real parts of $D(s)D(-s) + \rho N(s)N(-s)$:

$$D(s)D(-s) + \rho N(s)N(-s) = d_\rho(s)d_\rho(-s) \quad (4.233)$$

- Then the optimal controller $K(s) = q(s)/p(s)$ is the unique n^{th} order strictly proper transfer function such that:

$$D(s)p(s) + N(s)q(s) = d_\mu(s)d_\rho(s) \quad (4.234)$$

Chapter 5

Linear Quadratic Tracker (LQT)

5.1 Introduction

The regulator problem that has been tackled in the previous chapters is in fact a special case of a wider class of problems where the outputs of the system are required to follow a desired trajectory in some optimal sense. As underlined in the book of *Anderson and Moore* trajectory following problems can be conveniently separated into three different problems which depend on the nature of the desired output trajectory:

- If the plant outputs are to follow a class of desired trajectories, for example all polynomials up to certain order, the problem is referred to as a servo (servomechanism) problem;
- When the plant outputs are to follow the response of another plant (or model) the problem is referred to as model following problems;
- If the desired output trajectory is a particular prescribed function of time, the problem is called a tracking problem.

This chapter is devoted to the presentation of some results common to all three of these problems, with a particular attention being given on the tracking problem.

5.2 Control with feedforward

We will consider in this section the following linear system, where $\underline{x}(t)$ is the state-vector, $\underline{u}(t)$ the control and $\underline{y}(t)$ the controlled output (that is the output of interest):

$$\begin{cases} \dot{\underline{x}}(t) = \mathbf{A}\underline{x}(t) + \mathbf{B}\underline{u}(t) \\ \underline{y}(t) = \mathbf{C}\underline{x}(t) \end{cases} \quad (5.1)$$

Control with feedforward gain allows set point regulation. We will assume that control $\underline{u}(t)$ has the following expression where \mathbf{F} is the feedforward gain and where $\underline{r}(t)$ is the commanded value for the output $\underline{y}(t)$:

$$\underline{u}(t) = -\mathbf{K}\underline{x}(t) + \mathbf{F}\underline{r}(t) \quad (5.2)$$

The optimal control problem is then split into two separate problems which are solved individually to form the suboptimal control:

- First the commanded value $\underline{r}(t)$ is set to zero and the gain \mathbf{K} is computed to solve the Linear Quadratic Regulator (LQR) problem;
- Then the feedforward gain \mathbf{F} is computed such that the steady-state value of output $\underline{y}(t)$ is equal to the commanded value $\underline{r}(t) := \underline{y}_c$.

$$\underline{r}(t) := \underline{y}_c \quad (5.3)$$

Using the expression (5.2) of the control $\underline{u}(t)$ within the state space realization (5.1) of the linear system leads to:

$$\begin{cases} \dot{\underline{x}}(t) = \mathbf{A}\underline{x}(t) + \mathbf{B}\underline{u}(t) = (\mathbf{A} - \mathbf{BK})\underline{x}(t) + \mathbf{BF}\underline{y}_c \\ \underline{y}(t) = \mathbf{C}\underline{x}(t) \end{cases} \quad (5.4)$$

Then matrix \mathbf{F} is computed such that the steady-state value of output $\underline{y}(t)$ is \underline{y}_c . Assuming that $\dot{\underline{x}} = \underline{0}$, which corresponds to the steady-state, the preceding equations becomes:

$$\begin{cases} \underline{0} = (\mathbf{A} - \mathbf{BK})\underline{x} + \mathbf{BF}\underline{y}_c \Leftrightarrow \underline{x} = -(\mathbf{A} - \mathbf{BK})^{-1}\mathbf{BF}\underline{y}_c \\ \underline{y} = \mathbf{C}\underline{x} \end{cases} \quad (5.5)$$

That is:

$$\underline{y} = -\mathbf{C}(\mathbf{A} - \mathbf{BK})^{-1}\mathbf{BF}\underline{y}_c \quad (5.6)$$

Setting \underline{y} to \underline{y}_c and assuming that the size of the output vector $\underline{y}(t)$ is the same than the size of the control vector \underline{u} (square plant) leads to the following expression of the feedforward gain \mathbf{F} :

$$\underline{y} = \underline{y}_c \Rightarrow \mathbf{F} = -\left(\mathbf{C}(\mathbf{A} - \mathbf{BK})^{-1}\mathbf{B}\right)^{-1} \quad (5.7)$$

For a square plant the feedforward gain \mathbf{F} is nothing than the inverse of the closed-loop static gain (the closed-loop static gain is obtained by setting the Laplace variable s to 0 in the expression of the closed-loop transfer function).

5.3 Finite horizon Linear Quadratic Tracker

We will consider in this section the following linear system, where $\underline{x}(t)$ is the state-vector, $\underline{u}(t)$ the control and $\underline{y}(t)$ the measured output:

$$\begin{cases} \dot{\underline{x}}(t) = \mathbf{A}\underline{x}(t) + \mathbf{B}\underline{u}(t) \\ \underline{y}(t) = \mathbf{C}\underline{x}(t) \end{cases} \quad (5.8)$$

It is now desired to find an optimal control law in such a way that the controlled output $\underline{y}(t)$ tracks or follows a reference output $\underline{r}(t)$. Hence the performance index is defined as:

$$J(\underline{u}(t)) = \frac{1}{2}e^T(t_f)\mathbf{S}e(t_f) + \frac{1}{2}\int_0^{t_f} e^T(t)\mathbf{Q}e(t) + \underline{u}^T(t)\mathbf{R}\underline{u}(t) dt \quad (5.9)$$

Where $\underline{e}(t)$ is the trajectory error defined as:

$$\underline{e}(t) := \underline{y}(t) - \underline{r}(t) = \mathbf{C} \underline{x}(t) - \underline{r}(t) \quad (5.10)$$

The Hamiltonian H is then defined as:

$$H(\underline{x}, \underline{u}, \underline{\lambda}) = \frac{1}{2} \underline{e}^T(t) \mathbf{Q} \underline{e}(t) + \frac{1}{2} \underline{u}^T(t) \mathbf{R} \underline{u}(t) + \underline{\lambda}^T(t) (\mathbf{A} \underline{x}(t) + \mathbf{B} \underline{u}(t)) \quad (5.11)$$

The optimality condition (1.72) yields:

$$\frac{\partial H}{\partial \underline{u}} = \underline{0} = \mathbf{R} \underline{u}(t) + \mathbf{B}^T \underline{\lambda}(t) \Rightarrow \underline{u}(t) = -\mathbf{R}^{-1} \mathbf{B}^T \underline{\lambda}(t) \quad (5.12)$$

Equation (1.69) yields:

$$\begin{aligned} \dot{\underline{\lambda}}(t) &= -\frac{\partial H}{\partial \underline{x}} \\ &= -\left(\frac{\partial \underline{e}^T(t)}{\partial \underline{x}} \mathbf{Q} \underline{e}(t) + \mathbf{A}^T \underline{\lambda}(t) \right) \\ &= -\left(\mathbf{C}^T \mathbf{Q} (\mathbf{C} \underline{x}(t) - \underline{r}(t)) + \mathbf{A}^T \underline{\lambda}(t) \right) \\ \Leftrightarrow \dot{\underline{\lambda}}(t) &= -\mathbf{A}^T \underline{\lambda}(t) - \mathbf{C}^T \mathbf{Q} \mathbf{C} \underline{x}(t) + \mathbf{C}^T \mathbf{Q} \underline{r}(t) \end{aligned} \quad (5.13)$$

With the terminal condition (1.70):

$$\begin{aligned} \underline{\lambda}(t_f) &= \frac{\partial \frac{1}{2} \underline{e}^T(t_f) \mathbf{S} \underline{e}(t_f)}{\partial \underline{x}(t_f)} \\ &= \frac{\partial (\mathbf{C} \underline{x}(t_f) - \underline{r}(t_f))^T}{\partial \underline{x}(t_f)} \mathbf{S} \underline{e}(t_f) \\ &= \mathbf{C}^T \mathbf{S} (\mathbf{C} \underline{x}(t_f) - \underline{r}(t_f)) \end{aligned} \quad (5.14)$$

In order to get the closed-loop control law, expression (2.25) is modified through a feedforward term $\underline{g}(t)$ to be determined:

$$\boxed{\underline{\lambda}(t) = \mathbf{P}(t) \underline{x}(t) - \underline{g}(t)} \quad (5.15)$$

Using (5.15) the terminal conditions (5.14) can be written as:

$$\mathbf{P}(t_f) \underline{x}(t_f) - \underline{g}(t_f) = \mathbf{C}^T \mathbf{S} (\mathbf{C} \underline{x}(t_f) - \underline{r}(t_f)) \quad (5.16)$$

Which implies by identification:

$$\begin{cases} \mathbf{P}(t_f) = \mathbf{C}^T \mathbf{S} \mathbf{C} \\ \underline{g}(t_f) = \mathbf{C}^T \mathbf{S} \underline{r}(t_f) \end{cases} \quad (5.17)$$

Furthermore from (5.12) and (5.15) the control law reads:

$$\begin{aligned} \underline{u}(t) &= -\mathbf{R}^{-1} \mathbf{B}^T \underline{\lambda}(t) \\ &= -\mathbf{R}^{-1} \mathbf{B}^T (\mathbf{P}(t) \underline{x}(t) - \underline{g}(t)) \\ &= -\mathbf{R}^{-1} \mathbf{B}^T \mathbf{P}(t) \underline{x}(t) + \mathbf{R}^{-1} \mathbf{B}^T \underline{g}(t) \end{aligned} \quad (5.18)$$

From the preceding equation it is clear that the optimal control is the sum of two components:

- a state-feedback component: $-\mathbf{K}(t) \underline{x}(t)$ where $\mathbf{K}(t) = \mathbf{R}^{-1} \mathbf{B}^T \mathbf{P}(t)$;

– and a feedforward component: $\underline{v}(t) := \mathbf{R}^{-1}\mathbf{B}^T \underline{g}(t)$

In addition, differentiating (5.15) yields:

$$\dot{\underline{\lambda}}(t) = \dot{\mathbf{P}}(t)\underline{x}(t) + \mathbf{P}(t)\dot{\underline{x}}(t) - \dot{\underline{g}}(t) \quad (5.19)$$

Using (5.13) we get:

$$\begin{aligned} -\mathbf{A}^T \underline{\lambda}(t) - \mathbf{C}^T \mathbf{Q} \mathbf{C} \underline{x}(t) + \mathbf{C}^T \mathbf{Q} \underline{r}(t) \\ = \dot{\mathbf{P}}(t)\underline{x}(t) + \mathbf{P}(t)(\mathbf{A}\underline{x}(t) + \mathbf{B}\underline{u}(t)) - \dot{\underline{g}}(t) \end{aligned} \quad (5.20)$$

Using (5.8), (5.15) and (5.18) to express $\underline{u}(t)$ as a function of $\underline{x}(t)$ and $\underline{g}(t)$ we finally get:

$$\begin{aligned} \left(\dot{\mathbf{P}}(t) + \mathbf{A}^T \mathbf{P}(t) + \mathbf{P}(t)\mathbf{A} - \mathbf{P}(t)\mathbf{B}\mathbf{R}^{-1}\mathbf{B}^T \mathbf{P}(t) + \mathbf{C}^T \mathbf{Q} \mathbf{C} \right) \underline{x}(t) \\ - \dot{\underline{g}}(t) - (\mathbf{A}^T - \mathbf{P}(t)\mathbf{B}\mathbf{R}^{-1}\mathbf{B}^T) \underline{g}(t) - \mathbf{C}^T \mathbf{Q} \underline{r}(t) = \underline{0} \end{aligned} \quad (5.21)$$

The solution of (5.21) can be obtained by solving the preceding differential equation with final conditions (5.17) as two separate problems

$$\begin{cases} -\dot{\mathbf{P}}(t) = \mathbf{A}^T \mathbf{P}(t) + \mathbf{P}(t)\mathbf{A} - \mathbf{P}(t)\mathbf{B}\mathbf{R}^{-1}\mathbf{B}^T \mathbf{P}(t) + \mathbf{C}^T \mathbf{Q} \mathbf{C} \\ \mathbf{P}(t_f) = \mathbf{C}^T \mathbf{S} \mathbf{C} \end{cases} \quad (5.22)$$

and:

$$\begin{cases} -\dot{\underline{g}}(t) = (\mathbf{A}^T - \mathbf{P}(t)\mathbf{B}\mathbf{R}^{-1}\mathbf{B}^T) \underline{g}(t) + \mathbf{C}^T \mathbf{Q} \underline{r}(t) \\ \quad \quad \quad := (\mathbf{A} - \mathbf{B}\mathbf{K}(t))^T \underline{g}(t) + \mathbf{C}^T \mathbf{Q} \underline{r}(t) \\ \underline{g}(t_f) = \mathbf{C}^T \mathbf{S} \underline{r}(t_f) \end{cases} \quad (5.23)$$

Thus the implementation of the tracker (5.18) in real-time involves a standard optimal feedback regulator and a feedforward controller:

- The feedback regulator term requires the backward-in-time solution of the differential Riccati equation (5.22). This differential Riccati equation is independent of the reference signal $\underline{r}(t)$ and its solution has been studied in section 2.5.
- For particular applications where the reference signal $\underline{r}(t)$ is known a priori, the feedforward term $\underline{g}(t)$ can also be computed off-line by integrating, backwards in time, the differential equation (5.23). Backward integration is achieved when the time is reversed, that is by setting $\tau = t_f - t$ (thus the minus signs to the left of equality (5.23) is omitted). Then the initial value of the feedforward term $\underline{g}(0)$ is known and during the actual control run $\underline{g}(0)$ can be used to solve a forward differential equation instead¹.

¹Rocio Alba-Flores and Enrique Barbieri, Real-time Infinite Horizon Linear-Quadratic Tracking Controller for Vibration Quenching in Flexible Beams, 2006 IEEE Conference on Systems, Man, and Cybernetics, October 8-11, 2006, Taipei, Taiwan

5.4 Infinite horizon Linear Quadratic Tracker

5.4.1 General result

When infinite horizon is considered, the performance index (5.9) is changed as follows where the tracking error $\underline{e}(t)$ is defined in (5.10):

$$J(\underline{u}(t)) = \frac{1}{2} \int_0^\infty \underline{e}^T(t) \mathbf{Q} \underline{e}(t) + \underline{u}^T(t) \mathbf{R} \underline{u}(t) dt \quad (5.24)$$

Assuming that (\mathbf{A}, \mathbf{B}) is detectable and $(\mathbf{A}, \sqrt{\mathbf{Q}} \mathbf{C})$ is detectable, there exists a unique steady-state solution of equations (5.22) obtained through the corresponding algebraic Riccati equation. Assuming that we want to achieve a perfect tracking of $\underline{r}(t)$, control law (5.18) can be written as:

$$\underline{u}(t) = -\mathbf{R}^{-1} \mathbf{B}^T \mathbf{P} \underline{x}(t) + \mathbf{R}^{-1} \mathbf{B}^T \underline{g}(t) \quad (5.25)$$

Matrix \mathbf{P} is the positive definite solution of the following algebraic Riccati equation which is derived from (5.22) by setting $\dot{\mathbf{P}} = \mathbf{0}$:

$$\dot{\mathbf{P}} = \mathbf{0} \Rightarrow \mathbf{0} = \mathbf{A}^T \mathbf{P} + \mathbf{P} \mathbf{A} - \mathbf{P} \mathbf{B} \mathbf{R}^{-1} \mathbf{B}^T \mathbf{P} + \mathbf{C}^T \mathbf{Q} \mathbf{C} \quad (5.26)$$

On the other hand, feedforward term $\underline{g}(t)$ is derived from (5.23):

$$\begin{cases} \dot{\underline{g}}(t) = -(\mathbf{A} - \mathbf{B} \mathbf{K})^T \underline{g}(t) - \mathbf{C}^T \mathbf{Q} \underline{r}(t) \\ \lim_{t_f \rightarrow \infty} \underline{g}(t_f) = \mathbf{C}^T \mathbf{S} \underline{r}(t_f) \end{cases} \quad (5.27)$$

However, it is worth noticing that all the eigenvalues of state matrix $-(\mathbf{A} - \mathbf{B} \mathbf{K})^T$ are situated in the right half plane (thus unstable) because gain \mathbf{K} is such that all the eigenvalues of $(\mathbf{A} - \mathbf{B} \mathbf{K})$ are stable. Thus feedforward term $\underline{g}(t)$ is not bounded in general. Nevertheless the infinite horizon tracker can be approximated over a finite control interval $[0, t_f]$ by using the steady-state gain \mathbf{K} and the auxiliary function $\underline{g}(t)$ where t_f is large enough.

5.4.2 Asymptotically stable linear reference model

We will assume hereafter that the reference signal $\underline{r}(t)$ is given as the output of the following asymptotically stable linear reference model where \mathbf{A}_r is known and has all its eigenvalues in the left-half plane:

$$\dot{\underline{r}}(t) = \mathbf{A}_r \underline{r}(t) \quad (5.28)$$

Then by combining (5.8) and (5.28) the following augmented plant can be build with state-vector $\underline{x}_a(t) := \begin{bmatrix} \underline{x}(t) \\ \underline{r}(t) \end{bmatrix}$. We will denote \mathbf{A}_a , \mathbf{B}_a and \mathbf{C}_a the related matrices corresponding to the state-space representation of this augmented system:

$$\underline{x}_a(t) := \begin{bmatrix} \underline{x}(t) \\ \underline{r}(t) \end{bmatrix} \Rightarrow \begin{cases} \begin{bmatrix} \dot{\underline{x}}(t) \\ \dot{\underline{r}}(t) \end{bmatrix} = \begin{bmatrix} \mathbf{A} & \mathbf{0} \\ \mathbf{0} & \mathbf{A}_r \end{bmatrix} \begin{bmatrix} \underline{x}(t) \\ \underline{r}(t) \end{bmatrix} + \begin{bmatrix} \mathbf{B} \\ \mathbf{0} \end{bmatrix} \underline{u}(t) \\ \quad \quad \quad := \mathbf{A}_a \underline{x}_a(t) + \mathbf{B}_a \underline{u}(t) \\ \underline{e}(t) = \underline{y}(t) - \underline{r}(t) = \begin{bmatrix} \mathbf{C} & -\mathbf{I} \end{bmatrix} \underline{x}_a(t) \\ \quad \quad \quad := \mathbf{C}_a \underline{x}_a(t) \end{cases} \quad (5.29)$$

Then minimization of performance index (5.24) is achieved by applying classical results on LQR problems and control $\underline{u}(t)$ reads as follows²:

$$\underline{u}(t) = -\mathbf{K}_a \begin{bmatrix} \underline{x}(t) \\ \underline{r}(t) \end{bmatrix} \quad \text{where } \mathbf{K}_a = \mathbf{R}^{-1} \mathbf{B}_a^T \mathbf{P}_a \quad (5.30)$$

where \mathbf{P}_a is the positive definite solution of the following algebraic Riccati equation:

$$\mathbf{0} = \mathbf{A}_a^T \mathbf{P}_a + \mathbf{P}_a \mathbf{A}_a - \mathbf{P}_a \mathbf{B}_a \mathbf{R}^{-1} \mathbf{B}_a^T \mathbf{P}_a + \mathbf{C}_a^T \mathbf{Q} \mathbf{C}_a \quad (5.31)$$

5.4.3 Constant reference tracking

Finally, let's assume a constant value for $\underline{r}(t)$, which will be denoted \underline{r}_{ss} . Then at steady-state (5.8) reads as follows, where \underline{x}_{ss} denotes the steady-state of $\underline{x}(t)$:

$$\begin{cases} \underline{0} = \mathbf{A} \underline{x}_{ss} + \mathbf{B} \underline{u}_{ss} \\ \underline{y}_{ss} = \mathbf{C} \underline{x}_{ss} \end{cases} \quad (5.32)$$

If we impose $\underline{y}_{ss} := \underline{r}_{ss}$, the preceding relations read:

$$\underline{y}_{ss} := \underline{r}_{ss} \Rightarrow \begin{bmatrix} \underline{0} \\ \underline{r}_{ss} \end{bmatrix} = \begin{bmatrix} \mathbf{A} & \mathbf{B} \\ \mathbf{C} & \mathbf{0} \end{bmatrix} \begin{bmatrix} \underline{x}_{ss} \\ \underline{u}_{ss} \end{bmatrix} \quad (5.33)$$

Assuming that matrix $\begin{bmatrix} \mathbf{A} & \mathbf{B} \\ \mathbf{C} & \mathbf{0} \end{bmatrix}$ is square and invertible, we get:

$$\begin{aligned} \begin{bmatrix} \underline{x}_{ss} \\ \underline{u}_{ss} \end{bmatrix} &= \begin{bmatrix} \mathbf{A} & \mathbf{B} \\ \mathbf{C} & \mathbf{0} \end{bmatrix}^{-1} \begin{bmatrix} \underline{0} \\ \underline{r}_{ss} \end{bmatrix} \\ &:= \begin{bmatrix} \mathbf{M}_{11} & \mathbf{M}_{12} \\ \mathbf{M}_{21} & \mathbf{M}_{22} \end{bmatrix} \begin{bmatrix} \underline{0} \\ \underline{r}_{ss} \end{bmatrix} \\ &= \begin{bmatrix} \mathbf{M}_{12} \\ \mathbf{M}_{22} \end{bmatrix} \underline{r}_{ss} \end{aligned} \quad (5.34)$$

Then let $\tilde{\underline{x}}(t)$ the error between the actual state-vector $\underline{x}(t)$ and its steady-state value \underline{x}_{ss} and $\tilde{\underline{u}}(t)$ the error between the actual control $\underline{u}(t)$ and its steady-state value \underline{u}_{ss} :

$$\begin{cases} \tilde{\underline{x}}(t) := \underline{x}(t) - \underline{x}_{ss} \\ \tilde{\underline{u}}(t) := \underline{u}(t) - \underline{u}_{ss} \end{cases} \quad (5.35)$$

Then using (5.35) the dynamics of $\tilde{\underline{x}}(t)$ reads:

$$\begin{aligned} \dot{\tilde{\underline{x}}}(t) &= \dot{\underline{x}}(t) \\ &= \mathbf{A} \underline{x}(t) + \mathbf{B} \underline{u}(t) \\ &= \mathbf{A} (\tilde{\underline{x}}(t) + \underline{x}_{ss}) + \mathbf{B} (\tilde{\underline{u}}(t) + \underline{u}_{ss}) \end{aligned} \quad (5.36)$$

It is clear from (5.33) that $\mathbf{A} \underline{x}_{ss} + \mathbf{B} \underline{u}_{ss} = \underline{0}$. We finally get:

$$\mathbf{A} \underline{x}_{ss} + \mathbf{B} \underline{u}_{ss} = \underline{0} \Rightarrow \dot{\tilde{\underline{x}}}(t) = \mathbf{A} \tilde{\underline{x}}(t) + \mathbf{B} \tilde{\underline{u}}(t) \quad (5.37)$$

²Hamidreza Modares, Frank L. Lewis, Online Solution to the Linear Quadratic Tracking Problem of Continuous-time Systems using Reinforcement Learning, 52nd IEEE Conference on Decision and Control, December 10-13, 2013. Florence, Italy

In addition, the tracking error defined in (5.10) becomes:

$$\underline{e}(t) := \underline{y}(t) - r_{ss} = \mathbf{C} \underline{x}(t) - \mathbf{C} \underline{x}_{ss} = \mathbf{C} \tilde{\underline{x}}(t) \quad (5.38)$$

Then we consider the minimization of following performance index :

$$J(\tilde{\underline{u}}(t)) = \frac{1}{2} \int_0^\infty \underline{e}^T(t) \mathbf{Q} \underline{e}(t) + \tilde{\underline{u}}^T(t) \mathbf{R} \tilde{\underline{u}}(t) dt \quad (5.39)$$

The minimization of $J(\tilde{\underline{u}}(t))$ is achieved by applying classical results on LQR problems and control $\tilde{\underline{u}}(t)$ reads as follows:

$$\tilde{\underline{u}}(t) = -\mathbf{K} \tilde{\underline{x}}(t) \text{ where } \mathbf{K} = \mathbf{R}^{-1} \mathbf{B}^T \mathbf{P} \quad (5.40)$$

Matrix \mathbf{P} is the positive definite solution of the following algebraic Riccati equation:

$$\mathbf{0} = \mathbf{A}^T \mathbf{P} + \mathbf{P} \mathbf{A} - \mathbf{P} \mathbf{B} \mathbf{R}^{-1} \mathbf{B}^T \mathbf{P} + \mathbf{C}^T \mathbf{Q} \mathbf{C} \quad (5.41)$$

The actual control is finally obtained thanks to (5.35):

$$\underline{u}(t) = \tilde{\underline{u}}(t) + \underline{u}_{ss} = -\mathbf{K} \tilde{\underline{x}}(t) + \underline{u}_{ss} = -\mathbf{K} (\underline{x}(t) - \underline{x}_{ss}) + \underline{u}_{ss} \quad (5.42)$$

That is, using (5.34):

$$\begin{aligned} \underline{u}(t) &= -\mathbf{K} \underline{x}(t) + \mathbf{K} \underline{x}_{ss} + \underline{u}_{ss} \\ &= -\mathbf{K} \underline{x}(t) + \begin{bmatrix} \mathbf{K} & \mathbf{I} \end{bmatrix} \begin{bmatrix} \underline{x}_{ss} \\ \underline{u}_{ss} \end{bmatrix} \\ &= -\mathbf{K} \underline{x}(t) + \begin{bmatrix} \mathbf{K} & \mathbf{I} \end{bmatrix} \begin{bmatrix} \mathbf{A} & \mathbf{B} \\ \mathbf{C} & \mathbf{0} \end{bmatrix}^{-1} \begin{bmatrix} \underline{0} \\ r_{ss} \end{bmatrix} \\ &= -\mathbf{K} \underline{x}(t) + (\mathbf{K} \mathbf{M}_{12} + \mathbf{M}_{22}) r_{ss} \\ &= -\mathbf{K} \underline{x}(t) + \mathbf{F} r_{ss} \text{ where } \mathbf{F} := \mathbf{K} \mathbf{M}_{12} + \mathbf{M}_{22} \end{aligned} \quad (5.43)$$

5.5 Plant augmented with integrator

5.5.1 Integral augmentation

An alternative to make the steady-state error exactly equal to zero in response to a step for the commanded value $r(t) = \underline{y}_c$ is to replace the feedforward gain \mathbf{F} by an integrator which will cancel the steady-state error whatever the input step (the system's type is augmented to be of type 1). The advantage of adding an integrator is that it eliminates the need to determine the feedforward gain \mathbf{F} which could be difficult because of the uncertainty in the model.

By augmenting the system with the integral error the LQR routine will choose the value of the integral gain automatically.

The integrator is denoted \mathbf{T}/s , where $\mathbf{T} \neq \mathbf{0}$ is a constant which may be used to increase the response of the closed-loop system. Let \underline{x}_i be the additional component of the state-vector which is proportional to the integral of the error $\underline{e}(t) = r(t) - \underline{y}(t)$. Adding an integrator augments the system's dynamics as follows:

$$\begin{cases} \dot{\underline{x}}(t) = \mathbf{A}\underline{x}(t) + \mathbf{B}\underline{u}(t) \\ \underline{y}(t) = \mathbf{C}\underline{x}(t) \\ \dot{\underline{x}}_i(t) = \mathbf{T}\underline{e}(t) = \mathbf{T}(\underline{r}(t) - \underline{y}(t)) = \mathbf{T}\underline{r}(t) - \mathbf{T}\mathbf{C}\underline{x}(t) \end{cases} \quad (5.44)$$

$$\Leftrightarrow \begin{cases} \frac{d}{dt} \begin{bmatrix} \underline{x}(t) \\ \underline{x}_i(t) \end{bmatrix} = \begin{bmatrix} \mathbf{A} & \mathbf{0} \\ -\mathbf{T}\mathbf{C} & \mathbf{0} \end{bmatrix} \begin{bmatrix} \underline{x}(t) \\ \underline{x}_i(t) \end{bmatrix} + \begin{bmatrix} \mathbf{B} \\ \mathbf{0} \end{bmatrix} \underline{u}(t) + \begin{bmatrix} \mathbf{0} \\ \mathbf{T} \end{bmatrix} \underline{r}(t) \\ \underline{y}(t) = [\mathbf{C} \ \mathbf{0}] \begin{bmatrix} \underline{x}(t) \\ \underline{x}_i(t) \end{bmatrix} \end{cases}$$

Then, the suboptimal control is found by solving the LQR regulation problem where $\underline{r} = \underline{0}$:

- The augmented state space model reads:

$$\frac{d}{dt} \begin{bmatrix} \underline{x}(t) \\ \underline{x}_i(t) \end{bmatrix} = \dot{\underline{x}}_a(t) = \mathbf{A}_a \underline{x}_a(t) + \mathbf{B}_a \underline{u}(t) \text{ where } \begin{cases} \mathbf{A}_a = \begin{bmatrix} \mathbf{A} & \mathbf{0} \\ -\mathbf{T}\mathbf{C} & \mathbf{0} \end{bmatrix} \\ \mathbf{B}_a = \begin{bmatrix} \mathbf{B} \\ \mathbf{0} \end{bmatrix} \end{cases} \quad (5.45)$$

- The performance index $J(\underline{u}(t))$ to be minimized is the following:

$$J(\underline{u}(t)) = \frac{1}{2} \int_0^\infty \underline{x}_a^T(t) \mathbf{Q}_a \underline{x}_a(t) + \underline{u}^T(t) \mathbf{R} \underline{u}(t) dt \quad (5.46)$$

Where, denoting by \mathbf{N}_a a design matrix, matrix \mathbf{Q}_a is defined as follows:

$$\mathbf{Q}_a = \mathbf{N}_a^T \mathbf{N}_a \quad (5.47)$$

Note that design matrix \mathbf{N}_a shall be chosen such pair $(\mathbf{A}_a, \mathbf{N}_a)$ is detectable.

Assuming that pair $(\mathbf{A}_a, \mathbf{B}_a)$ is stabilizable and pair $(\mathbf{A}_a, \mathbf{N}_a)$ is detectable the algebraic Riccati equation can be solved. This leads to the following expression of the control $\underline{u}(t)$ (here feedforward gain \mathbf{F} no more exists):

$$\begin{aligned} \underline{u}(t) &= -\mathbf{K}_a \underline{x}_a(t) \\ &= -\mathbf{R}^{-1} \mathbf{B}_a^T \mathbf{P} \underline{x}_a(t) \\ &= -\mathbf{R}^{-1} [\mathbf{B}^T \ \mathbf{0}] \begin{bmatrix} \mathbf{P}_{11} & \mathbf{P}_{12} \\ \mathbf{P}_{21} & \mathbf{P}_{22} \end{bmatrix} \begin{bmatrix} \underline{x}(t) \\ \underline{x}_i(t) \end{bmatrix} \\ &= -\mathbf{R}^{-1} \mathbf{B}^T \mathbf{P}_{11} \underline{x}(t) - \mathbf{R}^{-1} \mathbf{B}^T \mathbf{P}_{12} \underline{x}_i(t) \\ &:= -\mathbf{K}_p \underline{x}(t) - \mathbf{K}_i \underline{x}_i(t) \end{aligned} \quad (5.48)$$

Obviously, term $\mathbf{K}_p = \mathbf{R}^{-1} \mathbf{B}^T \mathbf{P}_{11}$ represents the *proportional* gain of the controller whereas term $\mathbf{K}_i = \mathbf{R}^{-1} \mathbf{B}^T \mathbf{P}_{12}$ represents the *integral* gain of the controller.

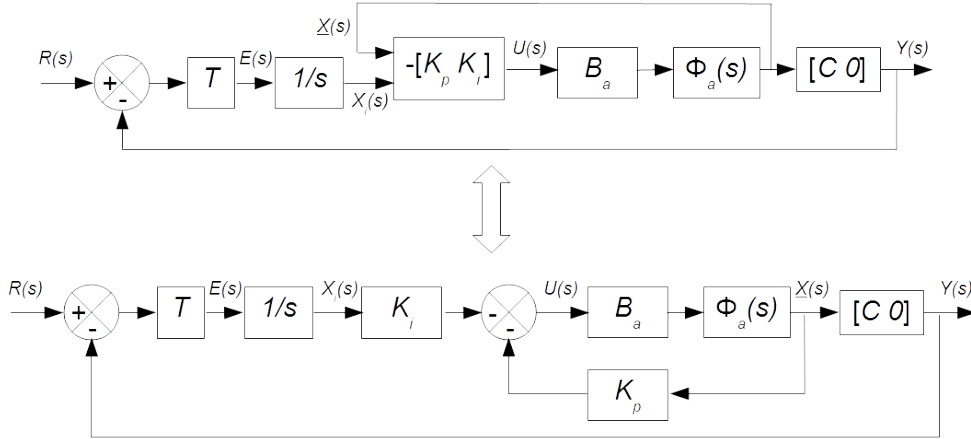

Figure 5.1: Plant augmented with integrator

The state space equation of closed-loop system is obtained by setting $\underline{u}(t) = -\mathbf{K}_a \underline{x}_a(t) = -\mathbf{K}_p \underline{x}(t) - \mathbf{K}_i \underline{x}_i(t)$ in (5.44):

$$\left\{ \begin{array}{l} \frac{d}{dt} \begin{bmatrix} \underline{x}(t) \\ \underline{x}_i(t) \end{bmatrix} = (\mathbf{A}_a - \mathbf{B}_a \mathbf{K}_a) \underline{x}_a(t) + \begin{bmatrix} \mathbf{0} \\ \mathbf{T} \end{bmatrix} \underline{r}(t) \\ \quad = \begin{bmatrix} \mathbf{A} - \mathbf{B} \mathbf{K}_p & -\mathbf{B} \mathbf{K}_i \\ -\mathbf{T} \mathbf{C} & \mathbf{0} \end{bmatrix} \begin{bmatrix} \underline{x}(t) \\ \underline{x}_i(t) \end{bmatrix} + \begin{bmatrix} \mathbf{0} \\ \mathbf{T} \end{bmatrix} \underline{r}(t) \\ \underline{y}(t) = [\mathbf{C} \ \mathbf{0}] \begin{bmatrix} \underline{x}(t) \\ \underline{x}_i(t) \end{bmatrix} \\ \underline{x}_i(t) = \mathbf{T} \int_0^t (\underline{r}(\tau) - \underline{y}(\tau)) d\tau \end{array} \right. \quad (5.49)$$

The corresponding bloc diagram is shown in Figure 5.1 where $\Phi_a(s) = (s\mathbb{I} - \mathbf{A}_a)^{-1}$.

5.5.2 Proof of the cancellation of the steady-state error through integral augmentation

In order to proof that integrator cancels the steady-state error when $\underline{r}(t)$ is a step input, let us compute the final value of the error $\underline{e}(t)$ using the final value theorem where s denotes the Laplace variable:

$$\lim_{t \rightarrow \infty} \underline{e}(t) = \lim_{s \rightarrow 0} s \underline{E}(s) \quad (5.50)$$

When $\underline{r}(t)$ is a step input with amplitude one, we have:

$$\underline{r}(t) = 1 \ \forall t \geq 0 \Rightarrow \underline{R}(s) = \frac{1}{s} \quad (5.51)$$

Using the feedback $\underline{u} = -\mathbf{K}_a \underline{x}_a$ the dynamics of the closed-loop system is:

$$\begin{aligned} \dot{\underline{x}}_a &= (\mathbf{A}_a - \mathbf{B}_a \mathbf{K}_a) \underline{x}_a + \begin{bmatrix} \mathbf{0} \\ \mathbf{T} \end{bmatrix} \underline{r}(t) \\ \Rightarrow \underline{e}(t) &= \mathbf{T} (\underline{r}(t) - \underline{y}(t)) \\ &= \mathbf{T} \left(\underline{r}(t) - [\mathbf{C} \ \mathbf{0}] \begin{bmatrix} \underline{x} \\ \underline{x}_i \end{bmatrix} \right) \\ &= \mathbf{T} (\underline{r}(t) - [\mathbf{C} \ \mathbf{0}] \underline{x}_a) \end{aligned} \quad (5.52)$$

Using the Laplace transform, and denoting by \mathbb{I} the identity matrix, we get:

$$\begin{cases} \underline{X}_a(s) = (s\mathbb{I} - \mathbf{A}_a + \mathbf{B}_a\mathbf{K}_a)^{-1} \begin{bmatrix} \mathbf{0} \\ \mathbf{T} \end{bmatrix} \underline{R}(s) \\ \underline{E}(s) = \mathbf{T} (\underline{R}(s) - [\mathbf{C} \ \mathbf{0}] \underline{X}_a(s)) \end{cases} \quad (5.53)$$

Inserting (5.51) in (5.53) we get:

$$\underline{E}(s) = \mathbf{T} \left(\mathbb{I} - [\mathbf{C} \ \mathbf{0}] (s\mathbb{I} - \mathbf{A}_a + \mathbf{B}_a\mathbf{K}_a)^{-1} \begin{bmatrix} \mathbf{0} \\ \mathbf{T} \end{bmatrix} \right) \frac{1}{s} \quad (5.54)$$

Then the final value theorem (5.50) takes the following expression:

$$\begin{aligned} \lim_{t \rightarrow \infty} \underline{e}(t) &= \lim_{s \rightarrow 0} s \underline{E}(s) \\ &= \lim_{s \rightarrow 0} \mathbf{T} \left(\mathbb{I} - [\mathbf{C} \ \mathbf{0}] (s\mathbb{I} - \mathbf{A}_a + \mathbf{B}_a\mathbf{K}_a)^{-1} \begin{bmatrix} \mathbf{0} \\ \mathbf{T} \end{bmatrix} \right) \\ &= \mathbf{T} \left(\mathbb{I} - [\mathbf{C} \ \mathbf{0}] (-\mathbf{A}_a + \mathbf{B}_a\mathbf{K}_a)^{-1} \begin{bmatrix} \mathbf{0} \\ \mathbf{T} \end{bmatrix} \right) \end{aligned} \quad (5.55)$$

Let us focus on the inverse of the matrix $-\mathbf{A}_a + \mathbf{B}_a\mathbf{K}_a$. First we write \mathbf{K}_a as $\mathbf{K}_a = [\mathbf{K}_p \ \mathbf{K}_i]$, where \mathbf{K}_p and \mathbf{K}_i represents respectively the proportional and the integral gains. Then using (5.45) we get:

$$-\mathbf{A}_a + \mathbf{B}_a\mathbf{K}_a = \begin{bmatrix} -\mathbf{A} & \mathbf{0} \\ \mathbf{TC} & \mathbf{0} \end{bmatrix} + \begin{bmatrix} \mathbf{B} \\ \mathbf{0} \end{bmatrix} [\mathbf{K}_p \ \mathbf{K}_i] = \begin{bmatrix} -\mathbf{A} + \mathbf{BK}_p & \mathbf{BK}_i \\ \mathbf{TC} & \mathbf{0} \end{bmatrix} \quad (5.56)$$

Assuming that \mathbf{X} is a square invertible matrix, it can be shown that the inverse of the matrix $\begin{bmatrix} \mathbf{X} & \mathbf{Y} \\ \mathbf{Z} & \mathbf{0} \end{bmatrix}$ is the following:

$$\begin{bmatrix} \mathbf{X} & \mathbf{Y} \\ \mathbf{Z} & \mathbf{0} \end{bmatrix}^{-1} = \begin{bmatrix} \mathbf{0} & \mathbf{Y}(\mathbf{ZY})^{-1} \\ \mathbf{Y}^T(\mathbf{YY}^T)^{-1} & \mathbf{W} \end{bmatrix} \quad \text{where } \mathbf{XY}(\mathbf{ZY})^{-1} + \mathbf{YW} = \mathbf{0} \quad (5.57)$$

Thus:

$$\begin{aligned} (-\mathbf{A}_a + \mathbf{B}_a\mathbf{K}_a)^{-1} &= \begin{bmatrix} -\mathbf{A} + \mathbf{BK}_p & \mathbf{BK}_i \\ \mathbf{TC} & \mathbf{0} \end{bmatrix}^{-1} \\ &= \begin{bmatrix} \mathbf{0} & \mathbf{BK}_i(\mathbf{TCBK}_i)^{-1} \\ (\mathbf{BK}_i)^T(\mathbf{BK}_i(\mathbf{BK}_i)^T)^{-1} & \mathbf{W} \end{bmatrix} \end{aligned} \quad (5.58)$$

And:

$$\begin{aligned} (-\mathbf{A}_a + \mathbf{B}_a\mathbf{K})^{-1} \begin{bmatrix} \mathbf{0} \\ \mathbf{T} \end{bmatrix} &= \begin{bmatrix} \mathbf{0} & \mathbf{BK}_i(\mathbf{TCBK}_i)^{-1} \\ * & \mathbf{W} \end{bmatrix} \begin{bmatrix} \mathbf{0} \\ \mathbf{T} \end{bmatrix} \\ &= \begin{bmatrix} \mathbf{BK}_i(\mathbf{TCBK}_i)^{-1} \mathbf{T} \\ \mathbf{WT} \end{bmatrix} \\ \Rightarrow [\mathbf{C} \ \mathbf{0}] (-\mathbf{A}_a + \mathbf{B}_a\mathbf{K})^{-1} \begin{bmatrix} \mathbf{0} \\ \mathbf{T} \end{bmatrix} &= [\mathbf{C} \ \mathbf{0}] \begin{bmatrix} \mathbf{BK}_i(\mathbf{TCBK}_i)^{-1} \mathbf{T} \\ \mathbf{WT} \end{bmatrix} \\ &= \mathbf{CBK}_i(\mathbf{TCBK}_i)^{-1} \mathbf{T} \end{aligned} \quad (5.59)$$

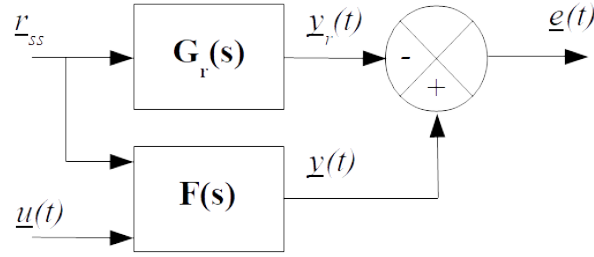
Figure 5.2: Linear Quadratic Tracker with constant reference signal \underline{r}_{ss}

Consequently, using (5.59) in (5.55), the final value of the error $\underline{e}(t)$ becomes:

$$\begin{aligned}
 \lim_{t \rightarrow \infty} \underline{e}(t) &= \mathbf{T} \left(\mathbb{I} - [\mathbf{C} \ \mathbf{0}] (-\mathbf{A}_a + \mathbf{B}_a \mathbf{K}_a)^{-1} \begin{bmatrix} \mathbf{0} \\ \mathbf{T} \end{bmatrix} \right) \\
 &= \mathbf{T} \left(\mathbb{I} - \mathbf{C} \mathbf{B} \mathbf{K}_i (\mathbf{T} \mathbf{C} \mathbf{B} \mathbf{K}_i)^{-1} \mathbf{T} \right) \\
 &= \mathbf{T} - \mathbf{T} \mathbf{C} \mathbf{B} \mathbf{K}_i (\mathbf{T} \mathbf{C} \mathbf{B} \mathbf{K}_i)^{-1} \mathbf{T} \\
 &= \mathbf{T} - \mathbf{T} \\
 &= \mathbf{0}
 \end{aligned} \tag{5.60}$$

As a consequence, the integrator allows to cancel the steady-state error whatever the input step $\underline{r}(t)$.

5.6 Tracking with prefilter

5.6.1 Tracking without integral augmentation

We consider Figure 5.2 and the problem to design a control $\underline{u}(t)$ which minimizes the error $\underline{e}(t)$ between the output $\underline{y}_r(t)$ of the reference model represented by $\mathbf{G}_r(s)$ and the actual output $\underline{y}(t)$ of the plant represented by $\mathbf{F}(s)$.

The state space realization of $\mathbf{G}_r(s)$ and $\mathbf{F}(s)$ are assumed to read as follows, where \underline{r}_{ss} is a *constant* reference signal and where input matrix \mathbf{B}_2 has been introduced to tackle the case where an integrator is inserted in the feedforward path of the loop, as presented in Section 5.5:

$$\left\{ \begin{array}{l} \mathbf{F}(s) : \begin{cases} \dot{\underline{x}}(t) = \mathbf{A}_1 \underline{x}(t) + \mathbf{B}_1 \underline{u}(t) + \mathbf{B}_2 \underline{r}_{ss} \\ \underline{y}(t) = \mathbf{C}_1 \underline{x}(t) \end{cases} \\ \mathbf{G}_r(s) : \begin{cases} \dot{\underline{x}}_r(t) = \mathbf{A}_r \underline{x}_r(t) + \mathbf{B}_r \underline{r}_{ss} \\ \underline{y}_r(t) = \mathbf{C}_r \underline{x}_r(t) \end{cases} \end{array} \right. \tag{5.61}$$

Assuming that no integrator is inserted in the feedforward path of the loop, matrices \mathbf{A}_1 , \mathbf{B}_1 and \mathbf{C}_1 are related to the state-space representation of the actual plant:

$$\left\{ \begin{array}{l} \mathbf{A}_1 := \mathbf{A} \\ \mathbf{B}_1 := \mathbf{B} \\ \mathbf{B}_2 := \mathbf{0} \\ \mathbf{C}_1 := \mathbf{C} \end{array} \right. \tag{5.62}$$

The tracking error $\underline{e}(t)$ reads:

$$\underline{e}(t) := \underline{y}(t) - \underline{y}_r(t) = \mathbf{C}_1 \underline{x}(t) - \mathbf{C}_r \underline{x}_r(t) \quad (5.63)$$

In order to solve this problem, we first compute the steady-state values imposing that at steady-state we shall have $\underline{y}_{ss} = \underline{y}_{r_{ss}}$. From (5.61) we get:

$$\begin{cases} 0 = \mathbf{A}_1 \underline{x}_{ss} + \mathbf{B}_1 \underline{u}_{ss} + \mathbf{B}_2 \underline{r}_{ss} \\ 0 = \mathbf{A}_r \underline{x}_{r_{ss}} + \mathbf{B}_r \underline{r}_{ss} \\ \underline{y}_{ss} = \underline{y}_{r_{ss}} \Leftrightarrow \mathbf{C}_1 \underline{x}_{ss} = \mathbf{C}_r \underline{x}_{r_{ss}} \end{cases} \Leftrightarrow \begin{bmatrix} -\mathbf{B}_2 \\ -\mathbf{B}_r \\ \mathbf{0} \end{bmatrix} \underline{r}_{ss} = \begin{bmatrix} \mathbf{A}_1 & \mathbf{0} & \mathbf{B}_1 \\ \mathbf{0} & \mathbf{A}_r & \mathbf{0} \\ \mathbf{C}_1 & -\mathbf{C}_r & \mathbf{0} \end{bmatrix} \begin{bmatrix} \underline{x}_{ss} \\ \underline{x}_{r_{ss}} \\ \underline{u}_{ss} \end{bmatrix} \quad (5.64)$$

Let matrix \mathbf{M} be defined as follows:

$$\mathbf{M} := \begin{bmatrix} \mathbf{A}_1 & \mathbf{0} & \mathbf{B}_1 \\ \mathbf{0} & \mathbf{A}_r & \mathbf{0} \\ \mathbf{C}_1 & -\mathbf{C}_r & \mathbf{0} \end{bmatrix} \quad (5.65)$$

Assuming that matrix \mathbf{M} is invertible, we get:

$$\begin{bmatrix} \underline{x}_{ss} \\ \underline{x}_{r_{ss}} \\ \underline{u}_{ss} \end{bmatrix} = \mathbf{M}^{-1} \begin{bmatrix} -\mathbf{B}_2 \\ -\mathbf{B}_r \\ \mathbf{0} \end{bmatrix} \underline{r}_{ss} \quad (5.66)$$

Let:

$$\mathbf{M}^{-1} \begin{bmatrix} -\mathbf{B}_2 \\ -\mathbf{B}_r \\ \mathbf{0} \end{bmatrix} := \begin{bmatrix} \mathbf{M}_1 \\ \mathbf{M}_2 \\ \mathbf{M}_3 \end{bmatrix} \quad (5.67)$$

Thus:

$$\boxed{\begin{bmatrix} \underline{x}_{ss} \\ \underline{x}_{r_{ss}} \\ \underline{u}_{ss} \end{bmatrix} = \begin{bmatrix} \mathbf{M}_1 \\ \mathbf{M}_2 \\ \mathbf{M}_3 \end{bmatrix} \underline{r}_{ss}} \quad (5.68)$$

Note that if matrix \mathbf{M} is not invertible, its pseudo inverse (Moore–Penrose inverse) \mathbf{M}^+ can be used instead of its inverse \mathbf{M}^{-1} . We recall that \mathbf{M}^+ is a generalization of the inverse of a matrix and is such that $\mathbf{M}\mathbf{M}^+\mathbf{M} = \mathbf{M}$ and $\mathbf{M}^+\mathbf{M}\mathbf{M}^+ = \mathbf{M}^+$. It can be computed by using the singular value decomposition (SVD) of \mathbf{M} : If $\mathbf{M} = \mathbf{U}\mathbf{\Sigma}\mathbf{V}^*$ is the singular value decomposition (SVD) of \mathbf{M} , then $\mathbf{M}^+ = \mathbf{V}\mathbf{\Sigma}^+\mathbf{U}^*$.

Then let $\tilde{\underline{x}}(t)$ the error between the actual state-vector $\underline{x}(t)$ and its steady-state value \underline{x}_{ss} , $\tilde{\underline{x}}_r(t)$ the error between the reference model state-vector $\underline{x}_r(t)$ and its steady-state value $\underline{x}_{r_{ss}}$ and $\tilde{\underline{u}}(t)$ the error between the actual control $\underline{u}(t)$ and its steady-state value \underline{u}_{ss} :

$$\begin{cases} \tilde{\underline{x}}(t) := \underline{x}(t) - \underline{x}_{ss} \\ \tilde{\underline{x}}_r(t) := \underline{x}_r(t) - \underline{x}_{r_{ss}} \\ \tilde{\underline{u}}(t) := \underline{u}(t) - \underline{u}_{ss} \end{cases} \quad (5.69)$$

Using (5.69) the dynamics of $\tilde{\underline{x}}(t)$ reads:

$$\begin{aligned}\tilde{\underline{x}}(t) &= \dot{\underline{x}}(t) \\ &= \mathbf{A}_1 \underline{x}(t) + \mathbf{B}_1 \underline{u}(t) + \mathbf{B}_2 \underline{r}_{ss} \\ &= \mathbf{A}_1 (\tilde{\underline{x}}(t) + \underline{x}_{ss}) + \mathbf{B}_1 (\tilde{\underline{u}}(t) + \underline{u}_{ss}) + \mathbf{B}_2 \underline{r}_{ss} \\ &= \mathbf{A}_1 \tilde{\underline{x}}(t) + \mathbf{B}_1 \tilde{\underline{u}}(t) + \mathbf{A}_1 \underline{x}_{ss} + \mathbf{B}_1 \underline{u}_{ss} + \mathbf{B}_2 \underline{r}_{ss}\end{aligned}\quad (5.70)$$

Similarly:

$$\begin{aligned}\tilde{\underline{x}}_r(t) &= \dot{\underline{x}}_r(t) \\ &= \mathbf{A}_r \underline{x}_r(t) + \mathbf{B}_r \underline{r}_{ss} \\ &= \mathbf{A}_r (\tilde{\underline{x}}_r(t) + \underline{x}_{r_{ss}}) + \mathbf{B}_r \underline{r}_{ss} \\ &= \mathbf{A}_r \tilde{\underline{x}}_r(t) + \mathbf{A}_r \underline{x}_{r_{ss}} + \mathbf{B}_r \underline{r}_{ss}\end{aligned}\quad (5.71)$$

It is clear from (5.64) that $\mathbf{A}_1 \underline{x}_{ss} + \mathbf{B}_1 \underline{u}_{ss} + \mathbf{B}_2 \underline{r}_{ss} = \underline{0}$ and $\mathbf{A}_r \underline{x}_{r_{ss}} + \mathbf{B}_r \underline{r}_{ss} = \underline{0}$. We finally get the following state space equation:

$$\begin{aligned}\begin{bmatrix} \dot{\tilde{\underline{x}}}(t) \\ \dot{\tilde{\underline{x}}}_r(t) \end{bmatrix} &= \begin{bmatrix} \mathbf{A}_1 & \mathbf{0} \\ \mathbf{0} & \mathbf{A}_r \end{bmatrix} \begin{bmatrix} \tilde{\underline{x}}(t) \\ \tilde{\underline{x}}_r(t) \end{bmatrix} + \begin{bmatrix} \mathbf{B}_1 \\ \mathbf{0} \end{bmatrix} \tilde{\underline{u}}(t) \\ &:= \mathbf{A}_a \begin{bmatrix} \tilde{\underline{x}}(t) \\ \tilde{\underline{x}}_r(t) \end{bmatrix} + \mathbf{B}_a \tilde{\underline{u}}(t)\end{aligned}\quad (5.72)$$

In addition, the tracking error defined in (5.63) becomes:

$$\begin{aligned}\underline{e}(t) &:= \underline{y}(t) - \underline{y}_r(t) \\ &= \mathbf{C}_1 \underline{x}(t) - \mathbf{C}_r \underline{x}_r(t) \\ &= \mathbf{C}_1 (\tilde{\underline{x}}(t) + \underline{x}_{ss}) - \mathbf{C}_r (\tilde{\underline{x}}_r(t) + \underline{x}_{r_{ss}}) \\ &= \mathbf{C}_1 \tilde{\underline{x}}(t) - \mathbf{C}_r \tilde{\underline{x}}_r(t) + \mathbf{C}_1 \underline{x}_{ss} - \mathbf{C}_r \underline{x}_{r_{ss}}\end{aligned}\quad (5.73)$$

Using the last equation of (5.64), we finally get the following output equation:

$$\begin{aligned}\mathbf{C}_1 \underline{x}_{ss} = \mathbf{C}_r \underline{x}_{r_{ss}} \Rightarrow \underline{e}(t) &= \mathbf{C}_1 \tilde{\underline{x}}(t) - \mathbf{C}_r \tilde{\underline{x}}_r(t) \\ &= \begin{bmatrix} \mathbf{C}_1 & -\mathbf{C}_r \end{bmatrix} \begin{bmatrix} \tilde{\underline{x}}(t) \\ \tilde{\underline{x}}_r(t) \end{bmatrix} \\ &:= \mathbf{C}_a \begin{bmatrix} \tilde{\underline{x}}(t) \\ \tilde{\underline{x}}_r(t) \end{bmatrix}\end{aligned}\quad (5.74)$$

Then we consider the minimization of following performance index :

$$J(\tilde{\underline{u}}(t)) = \frac{1}{2} \int_0^\infty \underline{e}^T(t) \mathbf{Q} \underline{e}(t) + \tilde{\underline{u}}^T(t) \mathbf{R} \tilde{\underline{u}}(t) dt \quad (5.75)$$

The minimization of $J(\tilde{\underline{u}}(t))$ is achieved by applying classical results on LQR problems and control $\tilde{\underline{u}}(t)$ reads as follows:

$$\tilde{\underline{u}}(t) = -\mathbf{K}_a \begin{bmatrix} \tilde{\underline{x}}(t) \\ \tilde{\underline{x}}_r(t) \end{bmatrix} \quad \text{where } \mathbf{K}_a = \mathbf{R}^{-1} \mathbf{B}_a^T \mathbf{P} \quad (5.76)$$

Matrix \mathbf{P} is the positive definite solution of the following algebraic Riccati equation:

$$\boxed{\mathbf{0} = \mathbf{A}_a^T \mathbf{P} + \mathbf{P} \mathbf{A}_a - \mathbf{P} \mathbf{B}_a \mathbf{R}^{-1} \mathbf{B}_a^T \mathbf{P} + \mathbf{C}_a^T \mathbf{Q} \mathbf{C}_a} \quad (5.77)$$

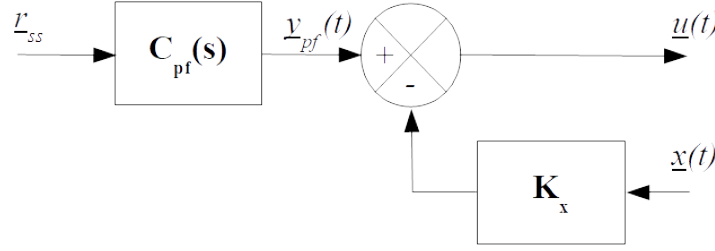

Figure 5.3: Linear Quadratic Tracker with prefilter

The actual control $\underline{u}(t)$ is finally obtained thanks to (5.69):

$$\begin{aligned}
 \underline{u}(t) &= \tilde{\underline{u}}(t) + \underline{u}_{ss} \\
 &= -\mathbf{K}_a \begin{bmatrix} \tilde{\underline{x}}(t) \\ \tilde{\underline{x}}_r(t) \end{bmatrix} + \underline{u}_{ss} \\
 &= -\mathbf{K}_a \begin{bmatrix} \underline{x}(t) \\ \underline{x}_r(t) \end{bmatrix} + \mathbf{K}_a \begin{bmatrix} \underline{x}_{ss} \\ \underline{x}_{r_{ss}} \end{bmatrix} + \underline{u}_{ss}
 \end{aligned} \tag{5.78}$$

That is, when splitting \mathbf{K}_a as $\mathbf{K}_a := [\mathbf{K}_x \quad \mathbf{K}_r]$ and using (5.68):

$$\begin{aligned}
 \underline{u}(t) &= -\mathbf{K}_a \begin{bmatrix} \underline{x}(t) \\ \underline{x}_r(t) \end{bmatrix} + \mathbf{K}_a \begin{bmatrix} \mathbf{M}_1 \\ \mathbf{M}_2 \end{bmatrix} \underline{r}_{ss} + \mathbf{M}_3 \underline{r}_{ss} \\
 &:= - [\mathbf{K}_x \quad \mathbf{K}_r] \begin{bmatrix} \underline{x}(t) \\ \underline{x}_r(t) \end{bmatrix} + \mathbf{D}_{pf} \underline{r}_{ss} \\
 &:= -\mathbf{K}_x \underline{x}(t) + \underline{y}_{pf}(t)
 \end{aligned} \tag{5.79}$$

where:

$$\begin{cases} \underline{y}_{pf}(t) = -\mathbf{K}_r \underline{x}_r(t) + \mathbf{D}_{pf} \underline{r}_{ss} \\ \mathbf{D}_{pf} := \mathbf{K}_a \begin{bmatrix} \mathbf{M}_1 \\ \mathbf{M}_2 \end{bmatrix} + \mathbf{M}_3 \end{cases} \tag{5.80}$$

Consequently the actual optimal control $\underline{u}(t)$ is the sum of two components:

- a state-feedback component: $-\mathbf{K}_x \underline{x}(t)$;
- and a feedforward component $\underline{y}_{pf}(t)$ with is obtained as the output of the a prefilter $\mathbf{C}_{pf}(s)$ with the following realization:

$$\mathbf{C}_{pf}(s) : \begin{cases} \dot{\underline{x}}_r(t) = \mathbf{A}_r \underline{x}_r(t) + \mathbf{B}_r \underline{r}_{ss} \\ \underline{y}_{pf}(t) = -\mathbf{K}_r \underline{x}_r(t) + \mathbf{D}_{pf} \underline{r}_{ss} \end{cases} \tag{5.81}$$

This is illustrated in Figure 5.3.

5.6.2 Tracking with integral augmentation

Assuming that an integrator is inserted in the feedforward path of the loop, as presented in Section 5.5, the state vector $\underline{x}(t)$ of the plant has to be extended by adding a new component $\underline{x}_i(t)$ in the state vector:

$$\underline{x}(t) \rightarrow \begin{bmatrix} \underline{x}(t) \\ \underline{x}_i(t) \end{bmatrix} \text{ where } \dot{\underline{x}}_i(t) = \mathbf{T}\underline{e}(t) = \mathbf{T}(\underline{r}(t) - \underline{y}(t)) \tag{5.82}$$

Then using (5.44) matrices \mathbf{A}_1 , \mathbf{B}_1 and \mathbf{C}_1 in (5.61) read as follows:

$$\left\{ \begin{array}{l} \mathbf{A}_1 := \begin{bmatrix} \mathbf{A} & \mathbf{0} \\ -\mathbf{TC} & \mathbf{0} \end{bmatrix} \\ \mathbf{B}_1 := \begin{bmatrix} \mathbf{B} \\ \mathbf{0} \end{bmatrix} \\ \mathbf{B}_2 := \begin{bmatrix} \mathbf{0} \\ \mathbf{T} \end{bmatrix} \\ \mathbf{C}_1 := \begin{bmatrix} \mathbf{C} & \mathbf{0} \end{bmatrix} \end{array} \right. \quad (5.83)$$

Nevertheless the algebraic Riccati equation (5.77) is not solvable because pair $(\mathbf{A}_a, \mathbf{C}_a)$ is no more observable. In order to tackle this point, weighting matrix $\mathbf{C}_a := [\mathbf{C}_1 \quad -\mathbf{C}_r] = [\mathbf{C} \quad \mathbf{0} \quad -\mathbf{C}_r]$ has to be changed, for example as follows:

$$\mathbf{C}_a := [\mathbf{C} \quad \underbrace{\mathbf{0}}_{\substack{\text{becomes } \mathbb{I}}} \quad -\mathbf{C}_r] \quad (5.84)$$

Finally steady-state value of the integral term $\underline{x}_i(t)$ is $\underline{x}_{i_{ss}} = \underline{0}$. Consequently, tracking with integral augmentation will not change steady-state values and (5.68) is still valid (meaning that \mathbf{B}_2 is assumed to be zero to compute steady-state values). This implies that the expression of the structure of the prefilter remains unchanged. Finally (5.80) now reads as follows where matrix $\mathbf{0}$ has been added after \mathbf{M}_1 in the expression of \mathbf{D}_{pf} to take into account the presence of integral term in the state vector of the augmented plant:

$$\left\{ \begin{array}{l} \underline{y}_{pf}(t) = -\mathbf{K}_r \underline{x}_r(t) + \mathbf{D}_{pf} r_{ss} \\ \mathbf{D}_{pf} := \mathbf{K}_a \begin{bmatrix} \mathbf{M}_1 \\ \mathbf{0} \\ \mathbf{M}_2 \end{bmatrix} + \mathbf{M}_3 \end{array} \right. \quad (5.85)$$

Chapter 6

Linear Quadratic Gaussian (LQG) regulator

6.1 Introduction

The design of the Linear Quadratic Regulator (LQR) assumes that the whole state is available for control and that there is no noise. Those assumptions may appear unrealistic in practical applications. We will assume in this chapter that the process to be controlled is described by the following linear time invariant model where $\underline{w}(t)$ and $\underline{v}(t)$ are random processes which represents the process noise and the measurement noise, respectively:

$$\begin{cases} \dot{\underline{x}}(t) = \mathbf{A}\underline{x}(t) + \mathbf{B}\underline{u}(t) + \underline{w}(t) \\ \underline{y}(t) = \mathbf{C}\underline{x}(t) + \underline{v}(t) \end{cases} \quad (6.1)$$

The preceding relation can be equivalently represented by the block diagram in Figure 6.1.

Linear Quadratic Gaussian (LQG) control deals with the design of a regulator which minimizes a quadratic cost using the available output and taking into account the noise into the process and the available output for control. More precisely the LQG control problem is to find the optimal control $\underline{u}(t)$ which minimizes the following performance index $J(\underline{u}(t))$ where $E(\cdot)$ is the

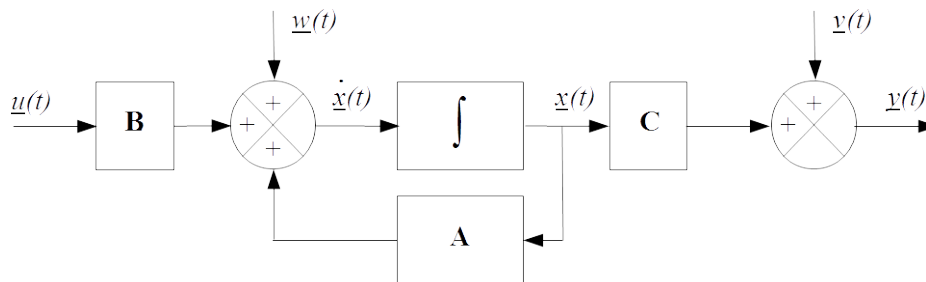

Figure 6.1: Open-loop linear system with process and measurement noises

mathematical expectation, $\mathbf{Q} = \mathbf{Q}^T \geq 0$ and $\mathbf{R} = \mathbf{R}^T > 0$:

$$J(\underline{u}(t)) = E \left(\lim_{t_f \rightarrow \infty} \frac{1}{2t_f} \int_0^{t_f} \underline{x}^T(t) \mathbf{Q} \underline{x}(t) + \underline{u}^T(t) \mathbf{R} \underline{u}(t) dt \right) \quad (6.2)$$

As far as only the output $y(t)$ is now available for control (not the full state $\underline{x}(t)$), the separation principle will be used to design the LQG regulator. Indeed, the solution of the LQG problem can be split into two steps:

- First an estimator will be used to estimate the full state using the available output $\underline{y}(t)$
- Then an LQ controller will be designed using the state estimation in place of the true (but unknown) state $\underline{x}(t)$

6.2 Luenberger observer

Consider a process with the following state space model where $\underline{y}(t)$ denotes the measured output and $\underline{u}(t)$ the control input:

$$\begin{cases} \dot{\underline{x}}(t) = \mathbf{A}\underline{x}(t) + \mathbf{B}\underline{u}(t) \\ \underline{y}(t) = \mathbf{C}\underline{x}(t) \end{cases} \quad (6.3)$$

We assume that $\underline{x}(t)$ cannot be measured and the goal of the observer is to estimate $\underline{x}(t)$ based on $\underline{y}(t)$. Luenberger observer (1964) provides an estimation of the state vector through the following differential equation where matrices \mathbf{F} , \mathbf{J} and \mathbf{L} have to be determined:

$$\frac{d}{dt} \hat{\underline{x}}(t) = \mathbf{F}\hat{\underline{x}}(t) + \mathbf{J}\underline{u}(t) + \mathbf{L}\underline{y}(t) \quad (6.4)$$

The estimation error $\underline{e}(t)$ is defined as follows:

$$\underline{e}(t) = \underline{x}(t) - \hat{\underline{x}}(t) \quad (6.5)$$

Thus using (6.3) and (6.4) its time derivative reads:

$$\dot{\underline{e}}(t) = \dot{\underline{x}}(t) - \dot{\hat{\underline{x}}}(t) = \mathbf{A}\underline{x}(t) + \mathbf{B}\underline{u}(t) - (\mathbf{F}\hat{\underline{x}}(t) + \mathbf{J}\underline{u}(t) + \mathbf{L}\underline{y}(t)) \quad (6.6)$$

Using (6.5) and the output equation $\underline{y}(t) = \mathbf{C}\underline{x}(t)$ the preceding relation can be rewritten as follows:

$$\begin{aligned} \dot{\underline{e}}(t) &= \mathbf{A}\underline{x}(t) + \mathbf{B}\underline{u}(t) - \mathbf{F}(\underline{x}(t) - \underline{e}(t)) - \mathbf{J}\underline{u}(t) - \mathbf{L}\mathbf{C}\underline{x}(t) \\ &= \mathbf{F}\underline{e}(t) + (\mathbf{A} - \mathbf{F} - \mathbf{L}\mathbf{C})\underline{x}(t) + (\mathbf{B} - \mathbf{J})\underline{u}(t) \end{aligned} \quad (6.7)$$

As soon as the purpose of the observer is to move the estimation error $\underline{e}(t)$ towards zero independently of control $\underline{u}(t)$ and *true* state vector $\underline{x}(t)$ we choose matrices \mathbf{F} and \mathbf{J} as follows:

$$\begin{cases} \mathbf{J} = \mathbf{B} \\ \mathbf{F} = \mathbf{A} - \mathbf{L}\mathbf{C} \end{cases} \quad (6.8)$$

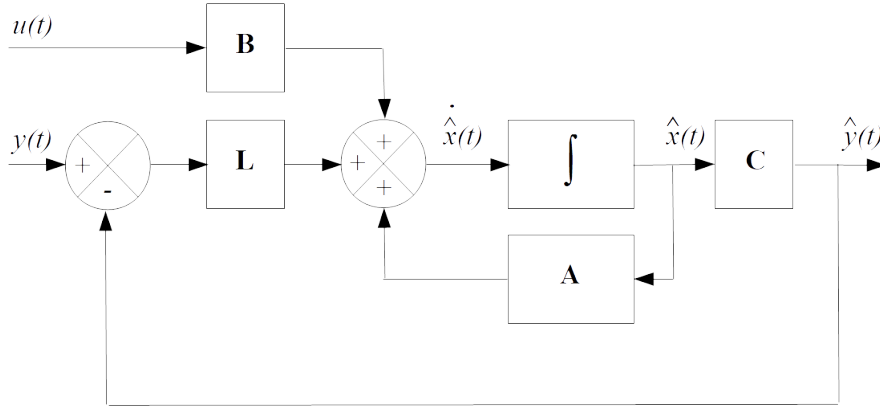

Figure 6.2: Luenberger observer

Thus the dynamics of the estimation error $\underline{e}(t)$ reduces to be:

$$\dot{\underline{e}}(t) = \mathbf{F}\underline{e}(t) = (\mathbf{A} - \mathbf{L}\mathbf{C})\underline{e}(t) \quad (6.9)$$

Where matrix \mathbf{L} shall be chosen such that all the eigenvalues of $\mathbf{A} - \mathbf{L}\mathbf{C}$ are situated in the left half plane. Furthermore the Luenberger observer (6.4) can now be written as follows using (6.8):

$$\begin{aligned} \dot{\hat{\underline{x}}}(t) &= (\mathbf{A} - \mathbf{L}\mathbf{C})\hat{\underline{x}}(t) + \mathbf{B}\underline{u}(t) + \mathbf{L}\underline{y}(t) \\ &= \mathbf{A}\hat{\underline{x}}(t) + \mathbf{B}\underline{u}(t) + \mathbf{L}(\underline{y}(t) - \mathbf{C}\hat{\underline{x}}(t)) \end{aligned} \quad (6.10)$$

Figure 6.2 shows the structure of the Luenberger observer.

6.3 White noise through Linear Time Invariant (LTI) system

6.3.1 Assumptions and definitions

Let's consider the following linear time invariant system which is fed by a random process $\underline{w}(t)$ of dimension n (which is also the dimension of the state vector $\underline{x}(t)$):

$$\begin{cases} \dot{\underline{x}}(t) = \mathbf{A}\underline{x}(t) + \mathbf{B}\underline{w}(t) \\ \underline{y}(t) = \mathbf{C}\underline{x}(t) \end{cases} \quad (6.11)$$

The mean of $\underline{w}(t)$ will be denoted $E[\underline{w}(t)]$ and its autocorrelation function $\mathbf{R}_w(\tau)$ will be denoted $E[\underline{w}(t)\underline{w}^T(t + \tau)]$ where E designates the expectation operator. We said that $\underline{w}(t)$ is a wide-sense stationary (WSS) random process when the two following properties hold:

- The mean $\underline{m}_w(t) := E[\underline{w}(t)]$ of $\underline{w}(t)$ is independent of t , that is constant;
- The autocorrelation function $\mathbf{R}_w(t, t + \tau)$ just depends on the time difference $\tau = (t + \tau) - t$:

$$\begin{aligned} \mathbf{R}_w(t, t + \tau) &= E\left[(\underline{w}(t) - \underline{m}_w(t))(\underline{w}(t + \tau) - \underline{m}_w(t + \tau))^T\right] \\ &:= \mathbf{R}_w(\tau) \end{aligned} \quad (6.12)$$

We will assume that $\underline{w}(t)$ is a white noise (which is a special case of a wide-sense stationary (WSS) random process) with zero mean Gaussian probability density function (pdf) $p(\underline{w})$. The covariance matrix of the Gaussian probability density function $p(\underline{w})$ will be denoted \mathbf{P}_w and the Dirac delta function will be denoted $\delta(\tau)$:

$$\begin{cases} p(\underline{w}) = \frac{1}{(2\pi)^{n/2} \sqrt{\det(\mathbf{P}_w)}} e^{-\frac{1}{2} \underline{w}^T \mathbf{P}_w^{-1} \underline{w}} \\ E[\underline{w}(t)] = \underline{m}_w(t) = \underline{0} \\ \mathbf{R}_w(\tau) = E[\underline{w}(t) \underline{w}^T(t + \tau)] = \mathbf{P}_w \delta(\tau) \text{ where } \mathbf{P}_w = \mathbf{P}_w^T > 0 \end{cases} \quad (6.13)$$

Because $\underline{w}(t)$ is a stochastic process, the differential equation $\dot{\underline{x}}(t) = \mathbf{A}\underline{x}(t) + \mathbf{B}\underline{w}(t)$ is called a stochastic differential equation. Moreover this particular type of stochastic differential equation where $\underline{w}(t)$ comes from the derivative of a Wiener process is called Langevin equation and can be written more elegantly as the following Ornstein-Uhlenbeck process where $\underline{w}(t)$ is a vector of Wiener process, also called Brownian motion:

$$d\underline{x}(t) = \mathbf{A}\underline{x}(t) dt + \mathbf{B} d\underline{w}(t) \quad (6.14)$$

6.3.2 Mean and covariance matrix of the state vector

As far as $\underline{w}(t)$ is a random process it is clear from (6.11) that the state vector $\underline{x}(t)$ and the output vector $\underline{y}(t)$ are also a random processes. When expanding the expression of the state vector obtained for deterministic signals we get:

$$\underline{x}(t) = e^{\mathbf{A}t} \underline{x}_0 + \int_0^t e^{\mathbf{A}(t-\tau)} \mathbf{B} \underline{w}(\tau) d\tau \quad (6.15)$$

Let $\underline{m}_x(0) = E[\underline{x}_0]$ be the mean of the initial value \underline{x}_0 of the state vector $\underline{x}(t)$ and $\mathbf{P}_x(0)$ the covariance matrix of the initial value \underline{x}_0 of the state vector. Then it can be shown that $\underline{x}(t)$ is a Gaussian random process with:

- Mean $\underline{m}_x(t)$ given by:

$$\underline{m}_x(t) = E[\underline{x}(t)] = e^{\mathbf{A}t} \underline{m}_x(0) \quad (6.16)$$

Assuming that $\underline{m}_x(0) = \underline{0}$ we get zero for the mean value of $\underline{x}(t)$:

$$\underline{m}_x(0) = \underline{0} \Rightarrow \underline{m}_x(t) = \underline{0} \quad (6.17)$$

- Covariance matrix $\mathbf{P}_x(t)$ which is defined as follows:

$$\mathbf{P}_x(t) = E[(\underline{x}(t) - \underline{m}_x(t)) (\underline{x}(t) - \underline{m}_x(t))^T] \quad (6.18)$$

Assuming that $\underline{m}_x(0) = \underline{0}$ we get:

$$\underline{m}_x(0) = \underline{0} \Rightarrow \mathbf{P}_x(t) = E[\underline{x}(t) \underline{x}(t)^T] \quad (6.19)$$

Finally, assuming that $\underline{m}_x(0) = \underline{0}$ and the input random process $\underline{w}(t)$ is a zero mean white noise with autocorrelation function $\mathbf{R}_w(\tau) = \mathbf{P}_w \delta(\tau)$ and is uncorrelated with the initial value \underline{x}_0 of the state vector, that is $E[\underline{x}_0 \underline{w}^T(\tau)] = \mathbf{0}$, then matrix $\mathbf{P}_x(t)$ reads as follows:

$$\begin{aligned}
\mathbf{P}_x(t) &= E[\underline{x}(t) \underline{x}(t)^T] \\
&= E\left[\left(e^{\mathbf{A}t} \underline{x}_0 + \int_0^t e^{\mathbf{A}(t-\tau)} \mathbf{B} \underline{w}(\tau) d\tau\right) \left(e^{\mathbf{A}t} \underline{x}_0 + \int_0^t e^{\mathbf{A}(t-\tau)} \mathbf{B} \underline{w}(\tau) d\tau\right)^T\right] \\
&= e^{\mathbf{A}t} \mathbf{P}_x(0) e^{\mathbf{A}^T t} + E\left[\left(\int_0^t e^{\mathbf{A}(t-\tau_1)} \mathbf{B} \underline{w}(\tau_1) d\tau_1\right) \left(\int_0^t e^{\mathbf{A}(t-\tau_2)} \mathbf{B} \underline{w}(\tau_2) d\tau_2\right)^T\right] \\
&= e^{\mathbf{A}t} \mathbf{P}_x(0) e^{\mathbf{A}^T t} + \int_0^t \int_0^t e^{\mathbf{A}(t-\tau)} \mathbf{B} E[\underline{w}(\tau) \underline{w}^T(\tau_1)] \mathbf{B}^T e^{\mathbf{A}^T(t-\tau_1)} d\tau d\tau_1 \\
&= e^{\mathbf{A}t} \mathbf{P}_x(0) e^{\mathbf{A}^T t} + \int_0^t \int_0^t e^{\mathbf{A}(t-\tau)} \mathbf{B} \mathbf{P}_w \delta(\tau_1 - \tau) \mathbf{B}^T e^{\mathbf{A}^T(t-\tau_1)} d\tau d\tau_1
\end{aligned} \tag{6.20}$$

Using the fact that $\int_0^t g(\tau_1) \delta(\tau_1 - \tau) d\tau_1 = g(\tau)$, we finally obtain:

$$\mathbf{P}_x(t) = e^{\mathbf{A}t} \mathbf{P}_x(0) e^{\mathbf{A}^T t} + \int_0^t e^{\mathbf{A}(t-\tau)} \mathbf{B} \mathbf{P}_w \mathbf{B}^T e^{\mathbf{A}^T(t-\tau)} d\tau \tag{6.21}$$

Because the evaluation of the preceding integral is difficult, we take the derivative of $\mathbf{P}_x(t)$ to get the following Lyapunov matrix differential equation where $\mathbf{P}_x(t) = \mathbf{P}_x^T(t) \geq 0$:

$$\dot{\mathbf{P}}_x(t) = \mathbf{A} \mathbf{P}_x(t) + \mathbf{P}_x(t) \mathbf{A}^T + \mathbf{B} \mathbf{P}_w \mathbf{B}^T \tag{6.22}$$

Assuming that the system is *stable* (i.e. all the eigenvalues of the state matrix \mathbf{A} have negative real part) the random process $\underline{x}(t)$ will become stationary after a certain amount of time: its mean $\underline{m}_x(t)$ will be zero whereas the value of its covariance matrix $\mathbf{P}_x(t)$ turns to be a constant matrix $\mathbf{P}_x = \mathbf{P}_x^T \geq 0 \forall t$ which solves the following matrix algebraic Lyapunov equation:

$$\mathbf{A} \mathbf{P}_x + \mathbf{P}_x \mathbf{A}^T + \mathbf{B} \mathbf{P}_w \mathbf{B}^T = \mathbf{0} \tag{6.23}$$

Thus after a certain amount of time the state vector $\underline{x}(t)$ as well as the output vector $\underline{y}(t)$ are wide-sense stationary (WSS) random processes.

6.3.3 Autocorrelation function of the stationary output vector

As in the previous section, we will assume in the following that $\underline{m}_x(0) = \underline{0}$. Let $\mathbf{R}_x(\tau)$ be the autocorrelation function of the stationary state vector $\underline{x}(t)$:

$$\mathbf{R}_x(\tau) = E[\underline{x}(t) \underline{x}(t + \tau)^T] \tag{6.24}$$

The autocorrelation function $\mathbf{R}_y(\tau)$ (which may be a matrix for vector signal) of the output vector $\underline{y}(t) = \mathbf{C} \underline{x}(t)$ is defined as follows:

$$\mathbf{R}_y(\tau) = E[\underline{y}(t) \underline{y}(t + \tau)^T] = \mathbf{C} \mathbf{R}_x(\tau) \mathbf{C}^T \tag{6.25}$$

It is clear from the definition of the autocorrelation function $\mathbf{R}_y(\tau)$ that the stationary value of the covariance matrix \mathbf{P}_y of $\underline{y}(t)$ is equal to the value of the autocorrelation function $\mathbf{R}_y(\tau)$ at $\tau = 0$:

$$\mathbf{P}_y = E [\underline{y}(t) \underline{y}(t)^T] = \mathbf{C} \mathbf{P}_x \mathbf{C}^T = \mathbf{R}_y(\tau)|_{\tau=0} \quad (6.26)$$

The power spectral density (psd) $\mathbf{S}_y(f)$ of a stationary process $\underline{y}(t)$ is given by the Fourier transform of its autocorrelation function $\mathbf{R}_y(\tau)$:

$$\mathbf{S}_y(f) = \int_{-\infty}^{+\infty} \mathbf{R}_y(\tau) e^{-j2\pi f\tau} d\tau \quad (6.27)$$

Then we will see in Section 6.3.4 that the following result holds:

$$\boxed{\mathbf{S}_y(f) = \mathbf{F}(-s) \mathbf{P}_w \mathbf{F}^T(s)|_{s=j2\pi f}} \quad (6.28)$$

where $\mathbf{F}(s)$ is the transfer function of the linear system, which is assumed to be *stable*:

$$\mathbf{F}(s) = \mathbf{C} (s\mathbb{I} - \mathbf{A})^{-1} \mathbf{B} \quad (6.29)$$

Relation (6.28) indicates that the power spectral density (psd) $\mathbf{S}_y(f)$ of $\underline{y}(t)$ can be obtained thanks to the transfer function $\mathbf{F}(s)$ of the *stable* linear system and the spectral density matrix \mathbf{P}_w of the exciting white noise $\underline{w}(t)$.

Let $\mathbf{S}_y(s)$ be the (one-sided) Laplace transform of the autocorrelation function $\mathbf{R}_y(\tau)$:

$$\mathbf{S}_y(s) = \mathcal{L} [\mathbf{R}_y(\tau)] = \int_0^{+\infty} \mathbf{R}_y(\tau) e^{-s\tau} d\tau \quad (6.30)$$

It can be seen that the power spectral density (psd) $\mathbf{S}_y(f)$ of $\underline{y}(t)$ can be obtained thanks to the (one-sided) Laplace transform $\mathbf{S}_y(s)$ of $\mathbf{R}_y(\tau)$ as:

$$\mathbf{S}_y(f) = \mathbf{S}_y(-s)|_{s=j2\pi f} + \mathbf{S}_y(s)|_{s=j2\pi f} \quad (6.31)$$

Indeed we can write:

$$\begin{aligned} \mathbf{S}_y(f) &= \int_{-\infty}^{+\infty} \mathbf{R}_y(\tau) e^{-j2\pi f\tau} d\tau \\ &= \int_{-\infty}^0 \mathbf{R}_y(\tau) e^{-j2\pi f\tau} d\tau + \int_0^{+\infty} \mathbf{R}_y(\tau) e^{-j2\pi f\tau} d\tau \\ &= \int_{-\infty}^0 \mathbf{R}_y(\tau) e^{-s\tau} d\tau \Big|_{s=j2\pi f} + \int_0^{+\infty} \mathbf{R}_y(\tau) e^{-s\tau} d\tau \Big|_{s=j2\pi f} \\ &= \int_0^{+\infty} \mathbf{R}_y(-\tau) e^{s\tau} d\tau \Big|_{s=j2\pi f} + \int_0^{+\infty} \mathbf{R}_y(\tau) e^{-s\tau} d\tau \Big|_{s=j2\pi f} \end{aligned} \quad (6.32)$$

As far as $\mathbf{R}_y(\tau)$ is an even function we get:

$$\begin{aligned} \mathbf{R}_y(-\tau) &= \mathbf{R}_y(\tau) \\ \Rightarrow \mathbf{S}_y(f) &= \int_0^{+\infty} \mathbf{R}_y(\tau) e^{s\tau} d\tau \Big|_{s=j2\pi f} + \int_0^{+\infty} \mathbf{R}_y(\tau) e^{-s\tau} d\tau \Big|_{s=j2\pi f} \end{aligned} \quad (6.33)$$

The preceding equations reads:

$$\mathbf{S}_y(f) = \mathbf{S}_y(-s)|_{s=j2\pi f} + \mathbf{S}_y(s)|_{s=j2\pi f} \quad (6.34)$$

Then, using (6.28), we can write:

$$\mathbf{S}_y(-s) + \mathbf{S}_y(s) = \mathbf{F}(-s) \mathbf{P}_w \mathbf{F}^T(s) \quad (6.35)$$

When identifying the *stable* transfer function $\mathbf{S}_y(s)$ in the preceding relation, we get the autocorrelation function $\mathbf{R}_y(\tau) \forall \tau \geq 0$ thank to the inverse (one-sided) Laplace transform of $\mathbf{S}_y(s)$:

$$\boxed{\begin{aligned} \mathbf{S}_y(-s) + \mathbf{S}_y(s) &= \mathbf{F}(-s) \mathbf{P}_w \mathbf{F}^T(s) \\ \Rightarrow \mathbf{R}_y(\tau) &= \mathcal{L}^{-1}[\mathbf{S}_y(s)] \quad \forall \tau \geq 0 \text{ where } \mathbf{S}_y(s) \text{ stable} \end{aligned}} \quad (6.36)$$

Finally using the initial value theorem on the (one-sided) Laplace transform $\mathbf{S}_y(s)$ we get the following result:

$$\mathbf{P}_y = \mathbf{R}_y(\tau)|_{\tau=0} = \lim_{s \rightarrow \infty} s \mathbf{S}_y(s) \quad (6.37)$$

Example 6.1. Let $\mathbf{F}(s)$ be a first order system with time constant a and let $\underline{w}(t)$ be a white noise with covariance \mathbf{P}_w :

$$\begin{cases} \mathbf{F}(s) = \frac{1}{1+as} \\ \mathbf{R}_w(\tau) = E[\underline{w}(t)\underline{w}^T(t+\tau)] = \mathbf{P}_w \delta(\tau) \text{ where } \mathbf{P}_w = \mathbf{P}_w^T > 0 \end{cases} \quad (6.38)$$

One realization of transfer function $\mathbf{F}(s)$ is the following:

$$\begin{cases} \dot{x}(t) = -\frac{1}{a}x(t) + \underline{w}(t) \\ y(t) = \frac{1}{a}x(t) \end{cases} \quad (6.39)$$

That is:

$$\begin{cases} \dot{\underline{x}}(t) = \mathbf{A}\underline{x}(t) + \mathbf{B}\underline{w}(t) \\ \underline{y}(t) = \mathbf{C}\underline{x}(t) \end{cases} \quad (6.40)$$

Where:

$$\begin{cases} \mathbf{A} = -\frac{1}{a} \\ \mathbf{B} = 1 \\ \mathbf{C} = \frac{1}{a} \end{cases} \Rightarrow \mathbf{F}(s) = \mathbf{C}(s\mathbb{I} - \mathbf{A})^{-1}\mathbf{B} \quad (6.41)$$

As far as $a > 0$ the system is stable. The covariance matrix $\mathbf{P}_x(t)$ is defined as follows:

$$\mathbf{P}_x(t) = E[(\underline{x}(t) - \underline{m}_x(t))(\underline{x}(t) - \underline{m}_x(t))^T] \quad (6.42)$$

Where matrix $\mathbf{P}_x(t)$ is the solution of the following Lyapunov differential equation:

$$\dot{\mathbf{P}}_x(t) = \mathbf{A}\mathbf{P}_x(t) + \mathbf{P}_x(t)\mathbf{A}^T + \mathbf{B}\mathbf{P}_w\mathbf{B}^T = -\frac{2}{a}\mathbf{P}_x(t) + \mathbf{P}_w \quad (6.43)$$

We get:

$$\mathbf{P}_x(t) = \frac{a}{2}\mathbf{P}_w + \left(\mathbf{P}_x(0) - \frac{a}{2}\mathbf{P}_w\right)e^{-\frac{2t}{a}} \quad (6.44)$$

The stationary value \mathbf{P}_x of the covariance matrix $\mathbf{P}_x(t)$ of the state vector $\underline{x}(t)$ is obtained as $t \rightarrow \infty$:

$$\mathbf{P}_x = \lim_{t \rightarrow \infty} \mathbf{P}_x(t) = \frac{a}{2}\mathbf{P}_w \quad (6.45)$$

Consequently the stationary value \mathbf{P}_y of the covariance matrix of the output vector $\underline{y}(t)$ reads:

$$\mathbf{P}_y = \mathbf{C}\mathbf{P}_x\mathbf{C}^T = \frac{1}{a^2} \times \frac{a}{2} \mathbf{P}_w = \frac{\mathbf{P}_w}{2a} \quad (6.46)$$

This result can be retrieved thanks to the power spectral density (psd) of the output vector $\underline{y}(t)$. Indeed let's compute the power spectral density (psd) $\mathbf{S}_y(f)$ of the output stationary process $\underline{y}(t)$ of the system:

$$\mathbf{S}_y(f) = \int_{-\infty}^{+\infty} \mathbf{R}_y(\tau) e^{-j2\pi f\tau} d\tau = \mathbf{F}(-s) \mathbf{P}_w \mathbf{F}^T(s) \Big|_{s=j2\pi f} \quad (6.47)$$

We get:

$$\begin{aligned} \mathbf{F}(-s) \mathbf{P}_w \mathbf{F}^T(s) &= \frac{\mathbf{P}_w}{(1+as)(1-as)} = \frac{\mathbf{P}_w}{1-(as)^2} \\ \Rightarrow \mathbf{S}_y(f) &= \mathbf{F}(-s) \mathbf{P}_w \mathbf{F}^T(s) \Big|_{s=j2\pi f} = \frac{\mathbf{P}_w}{1+(2\pi fa)^2} \end{aligned} \quad (6.48)$$

Furthermore let's decompose $\frac{\mathbf{P}_w}{1-(as)^2}$ as the sum $\mathbf{S}_y(-s) + \mathbf{S}_y(s)$:

$$\frac{\mathbf{P}_w}{1-(as)^2} = \frac{\mathbf{P}_w}{2} \frac{1}{1-as} + \frac{\mathbf{P}_w}{2} \frac{1}{1+as} = \mathbf{S}_y(-s) + \mathbf{S}_y(s) \quad (6.49)$$

Thus by identification we get for the stable transfer function $\mathbf{S}_y(s)$:

$$\mathbf{S}_y(s) = \frac{\mathbf{P}_w}{2} \frac{1}{1+as} \quad (6.50)$$

The autocorrelation function $\mathbf{R}_y(\tau)$ is given by the inverse Laplace transform of $\mathbf{S}_y(s)$:

$$\mathbf{R}_y(\tau) = \mathcal{L}^{-1}[\mathbf{S}_y(s)] = \mathcal{L}^{-1}\left[\frac{\mathbf{P}_w}{2a} \frac{1}{1/a+s}\right] = \frac{\mathbf{P}_w}{2a} e^{-\frac{\tau}{a}} \quad \forall \tau \geq 0 \quad (6.51)$$

As far as $\mathbf{R}_y(\tau)$ is an even function we get:

$$\mathbf{R}_y(\tau) = \frac{\mathbf{P}_w}{2a} e^{\frac{\tau}{a}} \quad \forall \tau \leq 0 \quad (6.52)$$

Thus the autocorrelation function $\mathbf{R}_y(\tau)$ for $\tau \in \mathbb{R}$ reads:

$$\mathbf{R}_y(\tau) = \frac{\mathbf{P}_w}{2a} e^{-\frac{|\tau|}{a}} \quad \forall \tau \in \mathbb{R} \quad (6.53)$$

Finally we use the initial value theorem on the (one-sided) Laplace transform $\mathbf{S}_y(s)$ to get the following result:

$$\mathbf{P}_y = \mathbf{R}_y(\tau) \Big|_{\tau=0} = \lim_{s \rightarrow \infty} s \mathbf{S}_y(s) = \frac{\mathbf{P}_w}{2a} \quad (6.54)$$

■

6.3.4 Proof of the expression of the autocorrelation function

The autocorrelation function $\mathbf{R}_y(t, t + \tau)$ of a non-stationary process reads as follows:

$$\begin{aligned}
 \mathbf{R}_y(t, t + \tau) &= E [y(t) y^T(t + \tau)] \\
 &= E [\mathbf{C} \underline{x}(t) \underline{x}^T(t + \tau) \mathbf{C}^T] \\
 &= \mathbf{C} E [\underline{x}(t) \underline{x}^T(t + \tau)] \mathbf{C}^T \\
 &= \mathbf{C} E \left[\left(\int_0^t e^{\mathbf{A}(t-\tau_1)} \mathbf{B} \underline{w}(\tau_1) d\tau_1 \right) \left(\int_0^{t+\tau} e^{\mathbf{A}(t+\tau-\tau_2)} \mathbf{B} \underline{w}(\tau_2) d\tau_2 \right)^T \right] \mathbf{C}^T \\
 &= \mathbf{C} \left(\int_0^t \int_0^{t+\tau} e^{\mathbf{A}(t-\tau_1)} \mathbf{B} E [\underline{w}(\tau_1) \underline{w}^T(\tau_2)] \mathbf{B}^T e^{\mathbf{A}^T(t+\tau-\tau_2)} d\tau_1 d\tau_2 \right) \mathbf{C}^T
 \end{aligned} \tag{6.55}$$

Using the facts that $\underline{w}(t)$ is a white noise, that is $E [\underline{w}(\tau_1) \underline{w}^T(\tau_2)] = \mathbf{P}_w \delta(\tau_2 - \tau_1)$, and that $\int_0^t g(\tau_1) \delta(\tau_2 - \tau_1) d\tau_1 = g(\tau_2)$, we get:

$$\begin{aligned}
 \mathbf{R}_y(t, t + \tau) &= \mathbf{C} \left(\int_0^t \int_0^{t+\tau} e^{\mathbf{A}(t-\tau_1)} \mathbf{B} \mathbf{P}_w \delta(\tau_2 - \tau_1) \mathbf{B}^T e^{\mathbf{A}^T(t+\tau-\tau_2)} d\tau_1 d\tau_2 \right) \mathbf{C}^T \\
 &= \mathbf{C} \left(\int_0^t e^{\mathbf{A}(t-\tau_2)} \mathbf{B} \mathbf{P}_w \mathbf{B}^T e^{\mathbf{A}^T(t+\tau-\tau_2)} d\tau_2 \right) \mathbf{C}^T
 \end{aligned} \tag{6.56}$$

Let $\xi := t - \tau_2 \Rightarrow d\xi = -d\tau_2$. Then:

$$\begin{aligned}
 \mathbf{R}_y(t, t + \tau) &= -\mathbf{C} \left(\int_t^0 e^{\mathbf{A}\xi} \mathbf{B} \mathbf{P}_w \mathbf{B}^T e^{\mathbf{A}^T(\xi+\tau)} d\xi \right) \mathbf{C}^T \\
 &= \mathbf{C} \left(\int_0^t e^{\mathbf{A}\xi} \mathbf{B} \mathbf{P}_w \mathbf{B}^T e^{\mathbf{A}^T(\xi+\tau)} d\xi \right) \mathbf{C}^T
 \end{aligned} \tag{6.57}$$

We finally get¹:

$$\boxed{\mathbf{R}_y(t, t + \tau) = \int_0^t \left(\mathbf{C} e^{\mathbf{A}\xi} \mathbf{B} \right) \mathbf{P}_w \left(\mathbf{C} e^{\mathbf{A}(\xi+\tau)} \mathbf{B} \right)^T d\xi} \tag{6.58}$$

Because t is the upper limit of the integral, the preceding autocorrelation function $\mathbf{R}_y(t, t + \tau)$ is not stationary. But stationary comes at $t \rightarrow \infty$ when the process reaches steady state:

$$\lim_{t \rightarrow \infty} \mathbf{R}_y(t, t + \tau) = \int_0^\infty \left(\mathbf{C} e^{\mathbf{A}\xi} \mathbf{B} \right) \mathbf{P}_w \left(\mathbf{C} e^{\mathbf{A}(\xi+\tau)} \mathbf{B} \right)^T d\xi := \mathbf{R}_y(\tau) \tag{6.59}$$

Of course (6.59) is valid only if the process has a steady state response, that is if the process is *stable*.

Then the power spectral density (psd) $\mathbf{S}_y(f)$ of $\underline{y}(t)$ is defined as the Fourier transform of the autocorrelation function $\mathbf{R}_y(\tau)$. We get from (6.59):

$$\begin{aligned}
 \mathbf{S}_y(f) &= \int_{-\infty}^{+\infty} \mathbf{R}_y(\tau) e^{-j2\pi f\tau} d\tau \\
 &= \int_{-\infty}^{+\infty} \left(\int_0^\infty \left(\mathbf{C} e^{\mathbf{A}\xi} \mathbf{B} \right) \mathbf{P}_w \left(\mathbf{C} e^{\mathbf{A}(\xi+\tau)} \mathbf{B} \right)^T d\xi \right) e^{-j2\pi f\tau} d\tau \\
 &= \int_0^\infty \left(\mathbf{C} e^{\mathbf{A}\xi} \mathbf{B} \right) \mathbf{P}_w \left(\int_{-\infty}^{+\infty} \left(\mathbf{C} e^{\mathbf{A}(\xi+\tau)} \mathbf{B} \right)^T e^{-j2\pi f\tau} d\tau \right) d\xi
 \end{aligned} \tag{6.60}$$

¹Friedland B., Control System Design: An Introduction to State-Space Methods, Dover Books on Electrical Engineering (2012)

Replacing $\xi + \tau$ by t in the bracketed integral yields:

$$\begin{aligned} \int_{-\infty}^{+\infty} (\mathbf{C} e^{\mathbf{A}(\xi+\tau)} \mathbf{B})^T e^{-j2\pi f\tau} d\tau &= \int_{-\infty}^{+\infty} (\mathbf{C} e^{\mathbf{A}t} \mathbf{B})^T e^{-j2\pi f(t-\xi)} dt \\ &= e^{j2\pi f\xi} \int_{-\infty}^{+\infty} (\mathbf{C} e^{\mathbf{A}t} \mathbf{B})^T e^{-j2\pi ft} dt \\ &= e^{j2\pi f\xi} \mathbf{F}^T(j2\pi f) \end{aligned} \quad (6.61)$$

where $\mathbf{F}(j2\pi f)$ is defined as follows:

$$\mathbf{F}(j2\pi f) = \int_{-\infty}^{+\infty} \mathbf{C} e^{\mathbf{A}t} \mathbf{B} e^{-j2\pi ft} dt \quad (6.62)$$

It is worth noticing that the time response of a *causal* system is zero $\forall t < 0$. So we recognize in $\mathbf{F}(j2\pi f)$ the transfer function of the linear system when $s = j2\pi f$. Indeed for a linear and causal system we have:

$$\begin{aligned} \mathbf{F}(j2\pi f) &= \int_{-\infty}^{+\infty} \mathbf{C} e^{\mathbf{A}t} \mathbf{B} e^{-j2\pi ft} dt \\ &= \int_0^{+\infty} \mathbf{C} e^{\mathbf{A}t} \mathbf{B} e^{-j2\pi ft} dt \\ &= \int_0^{+\infty} \mathbf{C} e^{\mathbf{A}t} \mathbf{B} e^{-st} dt \Big|_{s=j2\pi f} \\ &= \int_0^{+\infty} \mathbf{C} e^{-(s\mathbb{I}-\mathbf{A})t} \mathbf{B} dt \Big|_{s=j2\pi f} \\ &= \mathbf{C} (s\mathbb{I} - \mathbf{A})^{-1} \mathbf{B} \Big|_{s=j2\pi f} \\ &= \mathbf{F}(s) \Big|_{s=j2\pi f} \end{aligned} \quad (6.63)$$

Returning to (6.60), we get from the preceding results:

$$\begin{aligned} \mathbf{S}_y(f) &= \int_0^{\infty} (\mathbf{C} e^{\mathbf{A}\xi} \mathbf{B}) \mathbf{P}_w e^{j2\pi f\xi} \mathbf{F}^T(j2\pi f) d\xi \\ &= \left(\int_0^{\infty} (\mathbf{C} e^{\mathbf{A}\xi} \mathbf{B}) e^{j2\pi f\xi} d\xi \right) \mathbf{P}_w \mathbf{F}^T(j2\pi f) \\ &= \mathbf{F}(-j2\pi f) \mathbf{P}_w \mathbf{F}^T(j2\pi f) \end{aligned} \quad (6.64)$$

We finally retrieve result (6.28):

$$\mathbf{S}_y(f) = \mathbf{F}(-s) \mathbf{P}_w \mathbf{F}^T(s) \Big|_{s=j2\pi f} \quad (6.65)$$

This completes the proof. ■

6.4 Kalman-Bucy filter

6.4.1 Linear Quadratic Estimator

Let's consider the following linear time invariant model where $\underline{w}(t)$ and $\underline{v}(t)$ are random processes which represents the process noise and the measurement noise respectively:

$$\begin{cases} \dot{\underline{x}}(t) = \mathbf{A}\underline{x}(t) + \mathbf{B}\underline{u}(t) + \underline{w}(t) \\ \underline{y}(t) = \mathbf{C}\underline{x}(t) + \underline{v}(t) \end{cases} \quad (6.66)$$

The Kalman-Bucy filter is a state estimator that is optimal in the sense that it minimizes the covariance of the estimated error $\underline{e}(t) = \underline{x}(t) - \hat{\underline{x}}(t)$ when the following conditions are met:

- Random vectors $\underline{w}(t)$ and $\underline{v}(t)$ are zero mean Gaussian noise. Let $p(\underline{w})$ and $p(\underline{v})$ be the probability density function (pdf) of random processes $\underline{w}(t)$ and $\underline{v}(t)$. Then:

$$\begin{cases} p(\underline{w}) = \frac{1}{(2\pi)^{n/2} \sqrt{\det(\mathbf{P}_w)}} e^{-\frac{1}{2} \underline{w}^T \mathbf{P}_w^{-1} \underline{w}} \\ p(\underline{v}) = \frac{1}{(2\pi)^{p/2} \sqrt{\det(\mathbf{P}_v)}} e^{-\frac{1}{2} \underline{v}^T \mathbf{P}_v^{-1} \underline{v}} \end{cases} \quad (6.67)$$

- Random vectors $\underline{w}(t)$ and $\underline{v}(t)$ are white noise (i.e. uncorrelated). The covariance matrices of $\underline{w}(t)$ and $\underline{v}(t)$ will be denoted \mathbf{P}_w and \mathbf{P}_v respectively:

$$\begin{cases} E[\underline{w}(t) \underline{w}^T(t + \tau)] = \mathbf{P}_w \delta(\tau) \text{ where } \mathbf{P}_w = \mathbf{P}_w^T > 0 \\ E[\underline{v}(t) \underline{v}^T(t + \tau)] = \mathbf{P}_v \delta(\tau) \text{ where } \mathbf{P}_v = \mathbf{P}_v^T \geq 0 \end{cases} \quad (6.68)$$

- The cross correlation between $\underline{w}(t)$ and $\underline{v}(t)$ is zero:

$$\begin{cases} E[\underline{w}(t) \underline{v}^T(t + \tau)] = \mathbf{0} \\ E[\underline{v}(t) \underline{w}^T(t + \tau)] = \mathbf{0} \end{cases} \quad (6.69)$$

The Kalman-Bucy filter is a special form of the Luenberger observer (6.10):

$$\dot{\hat{\underline{x}}}(t) = \mathbf{A} \hat{\underline{x}}(t) + \mathbf{B} \underline{u}(t) + \mathbf{L}(t) (\underline{y}(t) - \mathbf{C} \hat{\underline{x}}(t)) \quad (6.70)$$

Where the time dependent observer gain $\mathbf{L}(t)$, also-called Kalman gain, is given by:

$$\mathbf{L}(t) = \mathbf{Y}(t) \mathbf{C}^T \mathbf{P}_v^{-1} \quad (6.71)$$

where matrix $\mathbf{Y}(t)$ is the solution of the following *differential* Riccati equation:

$$\dot{\mathbf{Y}}(t) = \mathbf{A} \mathbf{Y}(t) + \mathbf{Y}(t) \mathbf{A}^T - \mathbf{Y}(t) \mathbf{C}^T \mathbf{P}_v^{-1} \mathbf{C} \mathbf{Y}(t) + \mathbf{P}_w \quad (6.72)$$

The suboptimal observer gain $\mathbf{L} = \mathbf{Y} \mathbf{C}^T \mathbf{P}_v^{-1}$ is obtained thanks to the positive definite *steady state* solution $\mathbf{Y} = \mathbf{Y}^T > 0$ of the following *algebraic* Riccati equation:

$$\begin{cases} \mathbf{L} = \mathbf{Y} \mathbf{C}^T \mathbf{P}_v^{-1} \\ \mathbf{0} = \mathbf{A} \mathbf{Y} + \mathbf{Y} \mathbf{A}^T - \mathbf{Y} \mathbf{C}^T \mathbf{P}_v^{-1} \mathbf{C} \mathbf{Y} + \mathbf{P}_w \end{cases} \quad (6.73)$$

For *discrete time systems*, the following discrete time algebraic Riccati equation has to be solved to get the suboptimal observer gain, as shown in section 3.8:

$$\mathbf{Y} + \mathbf{A} \mathbf{Y} \mathbf{C}^T (\mathbf{P}_v + \mathbf{C} \mathbf{Y} \mathbf{C}^T)^{-1} \mathbf{C} \mathbf{Y} \mathbf{A}^T - \mathbf{A} \mathbf{Y} \mathbf{A}^T - \mathbf{P}_w = \mathbf{0} \quad (6.74)$$

Kalman gain shall be tuned when the covariance matrices \mathbf{P}_w and \mathbf{P}_v are not known:

- When measurements $\underline{y}(t)$ are very noisy the coefficients of covariance matrix \mathbf{P}_v are high and Kalman gain will be quite small;

- On the other hand when we do not trust very much the linear time invariant model of the process the coefficients of covariance matrix \mathbf{P}_w are high and Kalman gain will be quite high.

From a practical point of view matrices \mathbf{P}_w and \mathbf{P}_v are design parameters which are tuned to achieve the desired properties of the closed-loop.

Moreover, when the Riccati equation (6.72) related to the Kalman-Bucy filter is identified to the Riccati equation related the Linear-Quadratic-Regulator (LQR) we get:

$$\begin{aligned} \dot{\mathbf{Y}}(t) &= \mathbf{A}\mathbf{Y}(t) + \mathbf{Y}(t)\mathbf{A}^T - \mathbf{Y}(t)\mathbf{C}^T\mathbf{P}_v^{-1}\mathbf{C}\mathbf{Y}(t) + \mathbf{P}_w \\ &:= \mathbf{A}^T\mathbf{Y}(t) + \mathbf{Y}(t)\mathbf{A} - \mathbf{Y}(t)\mathbf{B}\mathbf{R}^{-1}\mathbf{B}^T\mathbf{Y}(t) + \mathbf{Q} \\ \Rightarrow &\begin{cases} \mathbf{Q} := \mathbf{P}_w \geq 0 \\ \mathbf{R} := \mathbf{P}_v > 0 \\ \mathbf{B} \rightarrow \mathbf{C}^T \\ \mathbf{A} \rightarrow \mathbf{A}^T \end{cases} \end{aligned} \quad (6.75)$$

6.4.2 Sketch of the proof

To get this result let's consider the following estimation error $\underline{e}(t)$:

$$\underline{e}(t) = \underline{x}(t) - \hat{\underline{x}}(t) \quad (6.76)$$

Thus using (6.66) and (6.70) its time derivative reads:

$$\begin{aligned} \dot{\underline{e}}(t) &= \dot{\underline{x}}(t) - \dot{\hat{\underline{x}}}(t) \\ &= \mathbf{A}\underline{x}(t) + \mathbf{B}\underline{u}(t) + \underline{w}(t) - (\mathbf{A}\hat{\underline{x}}(t) + \mathbf{B}\underline{u}(t) + \mathbf{L}(t)(\underline{y}(t) - \mathbf{C}\hat{\underline{x}}(t))) \\ &= \mathbf{A}\underline{e}(t) + \underline{w}(t) - \mathbf{L}(t)(\mathbf{C}\underline{x}(t) + \underline{v}(t) - \mathbf{C}\hat{\underline{x}}(t)) \\ &= (\mathbf{A} - \mathbf{L}(t)\mathbf{C})\underline{e}(t) + \underline{w}(t) - \mathbf{L}(t)\underline{v}(t) \end{aligned} \quad (6.77)$$

Since $\underline{v}(t)$ and $\underline{w}(t)$ are zero mean white noise their weighted sum $\underline{n}(t) = \underline{w}(t) - \mathbf{L}(t)\underline{v}(t)$ is also a zero mean white noise. We get:

$$\underline{n}(t) = \underline{w}(t) - \mathbf{L}(t)\underline{v}(t) \Rightarrow \dot{\underline{e}}(t) = (\mathbf{A} - \mathbf{L}(t)\mathbf{C})\underline{e}(t) + \underline{n}(t) \quad (6.78)$$

The covariance matrix \mathbf{P}_n of $\underline{n}(t)$ reads:

$$\begin{aligned} \mathbf{P}_n &= E[\underline{n}(t)\underline{n}^T(t)] \\ &= E[(\underline{w}(t) - \mathbf{L}(t)\underline{v}(t))(\underline{w}(t) - \mathbf{L}(t)\underline{v}(t))^T] \\ &= \mathbf{P}_w + \mathbf{L}(t)\mathbf{P}_v\mathbf{L}^T(t) \end{aligned} \quad (6.79)$$

Then the covariance matrix $\mathbf{Y}(t)$ of $\underline{e}(t)$ is obtained thanks to (6.22):

$$\begin{aligned} \dot{\mathbf{Y}}(t) &= (\mathbf{A} - \mathbf{L}(t)\mathbf{C})\mathbf{Y}(t) + \mathbf{Y}(t)(\mathbf{A} - \mathbf{L}(t)\mathbf{C})^T + \mathbf{P}_n \\ &= \mathbf{A}\mathbf{Y}(t) + \mathbf{Y}(t)\mathbf{A}^T - \mathbf{L}(t)\mathbf{C}\mathbf{Y}(t) - \mathbf{Y}(t)\mathbf{C}^T\mathbf{L}(t)^T + \mathbf{P}_n \end{aligned} \quad (6.80)$$

By using the expression (6.79) of the covariance matrix \mathbf{P}_n of $\underline{n}(t)$ we get:

$$\begin{aligned} \dot{\mathbf{Y}}(t) &= \mathbf{A}\mathbf{Y}(t) + \mathbf{Y}(t)\mathbf{A}^T + \mathbf{P}_w \\ &\quad - \mathbf{L}(t)\mathbf{C}\mathbf{Y}(t) - \mathbf{Y}(t)\mathbf{C}^T\mathbf{L}(t)^T + \mathbf{L}(t)\mathbf{P}_v\mathbf{L}^T(t) \end{aligned} \quad (6.81)$$

Let's complete the square of $-\mathbf{L}(t)\mathbf{C}\mathbf{Y}(t) - \mathbf{Y}(t)\mathbf{C}^T\mathbf{L}(t)^T + \mathbf{L}(t)\mathbf{P}_v\mathbf{L}^T(t)$. First we will focus on the scalar case where we try to minimize the following quadratic function $f(\mathbf{L})$ where $\mathbf{P}_v > 0$:

$$f(\mathbf{L}) = -2\mathbf{L}\mathbf{C}\mathbf{Y} + \mathbf{P}_v\mathbf{L}^2 \quad (6.82)$$

Completing the square of $f(\mathbf{L})$ means writing $f(\mathbf{L})$ as follows:

$$f(\mathbf{L}) = \mathbf{P}_v^{-1}(\mathbf{L}\mathbf{P}_v - \mathbf{Y}\mathbf{C})^2 - \mathbf{Y}^2\mathbf{C}^2\mathbf{P}_v^{-1} \quad (6.83)$$

Then it is clear that $f(\mathbf{L})$ is minimal when $\mathbf{L}\mathbf{P}_v - \mathbf{Y}\mathbf{C}$ and that the minimal value of $f(\mathbf{L})$ is $-\mathbf{Y}^2\mathbf{C}^2\mathbf{P}_v^{-1}$. This approach can be extended to the matrix case. When we complete the square of $-\mathbf{L}(t)\mathbf{C}\mathbf{Y}(t) - \mathbf{Y}(t)\mathbf{C}^T\mathbf{L}(t)^T + \mathbf{L}(t)\mathbf{P}_v\mathbf{L}^T(t)$ we get:

$$\begin{aligned} -\mathbf{L}(t)\mathbf{C}\mathbf{Y}(t) - \mathbf{Y}(t)\mathbf{C}^T\mathbf{L}(t)^T + \mathbf{L}(t)\mathbf{P}_v\mathbf{L}^T(t) = \\ (\mathbf{L}(t)\mathbf{P}_v - \mathbf{Y}(t)\mathbf{C}^T) \mathbf{P}_v^{-1} (\mathbf{L}(t)\mathbf{P}_v - \mathbf{Y}(t)\mathbf{C}^T)^T \\ - \mathbf{Y}(t)\mathbf{C}^T\mathbf{P}_v^{-1}\mathbf{C}\mathbf{Y}(t) \end{aligned} \quad (6.84)$$

Using the preceding relation within (6.81) reads:

$$\begin{aligned} \dot{\mathbf{Y}}(t) = \mathbf{A}\mathbf{Y}(t) + \mathbf{Y}(t)\mathbf{A}^T + \mathbf{P}_w \\ + (\mathbf{L}(t)\mathbf{P}_v - \mathbf{Y}(t)\mathbf{C}^T) \mathbf{P}_v^{-1} (\mathbf{L}(t)\mathbf{P}_v - \mathbf{Y}(t)\mathbf{C}^T)^T \\ - \mathbf{Y}(t)\mathbf{C}^T\mathbf{P}_v^{-1}\mathbf{C}\mathbf{Y}(t) \end{aligned} \quad (6.85)$$

In order to find the optimum observer gain $\mathbf{L}(t)$ which minimizes the covariance matrix $\mathbf{Y}(t)$ we choose $\mathbf{L}(t)$ such that $\mathbf{Y}(t)$ decreases by the maximum amount possible at each instant in time. This is accomplished by setting $\mathbf{L}(t)$ as follows:

$$\mathbf{L}(t)\mathbf{P}_v - \mathbf{Y}(t)\mathbf{C}^T = \mathbf{0} \Leftrightarrow \mathbf{L}(t) = \mathbf{Y}(t)\mathbf{C}^T\mathbf{P}_v^{-1} \quad (6.86)$$

Once $\mathbf{L}(t)$ is set such that $\mathbf{L}(t)\mathbf{P}_v - \mathbf{Y}(t)\mathbf{C}^T = \mathbf{0}$ the matrix differential equation (6.85) reads as follows:

$$\dot{\mathbf{Y}}(t) = \mathbf{A}\mathbf{Y}(t) + \mathbf{Y}(t)\mathbf{A}^T - \mathbf{Y}(t)\mathbf{C}^T\mathbf{P}_v^{-1}\mathbf{C}\mathbf{Y}(t) + \mathbf{P}_w \quad (6.87)$$

This is Equation (6.72).

6.5 Duality principle

In the chapter dedicated to the closed-loop solution of the infinite horizon Linear Quadratic Regulator (LQR) problem we have seen that the minimization of the cost functional $J(\underline{u}(t))$:

$$J(\underline{u}(t)) = \frac{1}{2} \int_0^\infty \underline{x}^T(t)\mathbf{Q}\underline{x}(t) + \underline{u}^T(t)\mathbf{R}\underline{u}(t)dt \quad (6.88)$$

Under the constraint

$$\begin{cases} \dot{\underline{x}}(t) = \mathbf{A}\underline{x}(t) + \mathbf{B}\underline{u}(t) \\ \underline{x}(0) = \underline{x}_0 \end{cases} \quad (6.89)$$

This leads to solving the following algebraic Riccati equation where $\mathbf{Q} = \mathbf{Q}^T \geq 0$ (thus \mathbf{Q} is symmetric and positive semi-definite matrix), and $\mathbf{R} = \mathbf{R}^T > 0$ is a symmetric and positive definite matrix:

$$\mathbf{0} = \mathbf{A}^T \mathbf{P} + \mathbf{P} \mathbf{A} - \mathbf{P} \mathbf{B} \mathbf{R}^{-1} \mathbf{B}^T \mathbf{P} + \mathbf{Q} \quad (6.90)$$

The constant suboptimal Kalman gain \mathbf{K} and the suboptimal stabilizing control $\underline{u}(t)$ are then defined as follows :

$$\begin{cases} \underline{u}(t) = -\mathbf{K}\underline{x}(t) \\ \mathbf{K} = \mathbf{R}^{-1} \mathbf{B}^T \mathbf{P} \end{cases} \quad (6.91)$$

Then let's compare the preceding relations with the following relations which are actually those which have been seen in (6.73):

$$\begin{cases} \mathbf{L} = \mathbf{Y} \mathbf{C}^T \mathbf{P}_v^{-1} \\ \mathbf{0} = \mathbf{Y} \mathbf{A}^T + \mathbf{A} \mathbf{Y} - \mathbf{Y} \mathbf{C}^T \mathbf{P}_v^{-1} \mathbf{C} \mathbf{Y} + \mathbf{P}_w \end{cases} \quad (6.92)$$

Then it is clear than the duality principle on Table 6.1 between observer and controller gains apply.

Controller	Observer
\mathbf{A}	\mathbf{A}^T
\mathbf{B}	\mathbf{C}^T
\mathbf{C}	\mathbf{B}^T
\mathbf{K}	\mathbf{L}^T
$\mathbf{P} = \mathbf{P}^T \geq 0$	$\mathbf{Y} = \mathbf{Y}^T \geq 0$
$\mathbf{Q} = \mathbf{Q}^T \geq 0$	$\mathbf{P}_w = \mathbf{P}_w^T \geq 0$
$\mathbf{R} = \mathbf{R}^T > 0$	$\mathbf{P}_v = \mathbf{P}_v^T > 0$
$\mathbf{A} - \mathbf{B} \mathbf{K}$	$\mathbf{A}^T - \mathbf{C}^T \mathbf{L}^T$

Table 6.1: Duality principle

6.6 Separation principle

Let $\underline{e}(t)$ be the state estimation error:

$$\underline{e}(t) = \underline{x}(t) - \hat{\underline{x}}(t) \quad (6.93)$$

Using (6.109) we get the following expressions for the dynamics of the state vector $\underline{x}(t)$:

$$\begin{aligned} \dot{\underline{x}}(t) &= \mathbf{A}\underline{x}(t) + \mathbf{B}\underline{u}(t) + \underline{w}(t) \\ &= \mathbf{A}\underline{x}(t) - \mathbf{B} \mathbf{K} \hat{\underline{x}}(t) + \underline{w}(t) \\ &= \mathbf{A}\underline{x}(t) - \mathbf{B} \mathbf{K} (\underline{x}(t) - \underline{e}(t)) + \underline{w}(t) \\ &= (\mathbf{A} - \mathbf{B} \mathbf{K}) \underline{x}(t) + \mathbf{B} \mathbf{K} \underline{e}(t) + \underline{w}(t) \end{aligned} \quad (6.94)$$

In addition using (6.108) and $\underline{y}(t) = \mathbf{C}\underline{x}(t) + \underline{v}(t)$ we get the following expressions for the dynamics of the estimation error $\underline{e}(t)$:

$$\begin{aligned}\dot{\underline{e}}(t) &= \dot{\underline{x}}(t) - \dot{\hat{\underline{x}}}(t) \\ &= \mathbf{A}\underline{x}(t) + \mathbf{B}\underline{u}(t) + \underline{w}(t) - (\mathbf{A}\hat{\underline{x}}(t) + \mathbf{B}\underline{u}(t) + \mathbf{L}(\underline{y}(t) - \mathbf{C}\hat{\underline{x}}(t))) \\ &= (\mathbf{A} - \mathbf{L}\mathbf{C})\underline{e}(t) + \underline{w}(t) - \mathbf{L}\underline{v}(t)\end{aligned}\quad (6.95)$$

Thus the closed-loop dynamics is defined as follows:

$$\begin{bmatrix} \dot{\underline{x}}(t) \\ \dot{\underline{e}}(t) \end{bmatrix} = \begin{bmatrix} \mathbf{A} - \mathbf{B}\mathbf{K} & \mathbf{B}\mathbf{K} \\ \mathbf{0} & \mathbf{A} - \mathbf{L}\mathbf{C} \end{bmatrix} \begin{bmatrix} \underline{x}(t) \\ \underline{e}(t) \end{bmatrix} + \begin{bmatrix} \underline{w}(t) \\ \underline{w}(t) - \mathbf{L}\underline{v}(t) \end{bmatrix}\quad (6.96)$$

From equations (6.96) it is clear that the $2n$ eigenvalues of the closed-loop are just the union between the n eigenvalues of the state-feedback coming from the spectrum of $\mathbf{A} - \mathbf{B}\mathbf{K}$ and the n eigenvalues of the state estimator coming from the spectrum of $\mathbf{A} - \mathbf{L}\mathbf{C}$. This result is called the separation principle. More precisely the separation principle states that the optimal control law is achieved by adopting the following two steps procedure:

- First assume an exact measurement of the full state to solve the deterministic Linear Quadratic (LQ) control problem which minimizes the following cost functional $J(\underline{u}(t))$:

$$J(\underline{u}(t)) = \frac{1}{2} \int_0^{\infty} \underline{x}^T(t)\mathbf{Q}\underline{x}(t) + \underline{u}^T(t)\mathbf{R}\underline{u}(t)dt \quad (6.97)$$

This leads to the following stabilizing control $\underline{u}(t)$:

$$\underline{u}(t) = -\mathbf{K}\underline{x}(t) \quad (6.98)$$

Where the Kalman gain $\mathbf{K} = \mathbf{R}^{-1}\mathbf{B}^T\mathbf{P}$ is obtained thanks to the positive semi-definite solution \mathbf{P} of the following algebraic Riccati equation:

$$\mathbf{0} = \mathbf{A}^T\mathbf{P} + \mathbf{P}\mathbf{A} - \mathbf{P}\mathbf{B}\mathbf{R}^{-1}\mathbf{B}^T\mathbf{P} + \mathbf{Q} \quad (6.99)$$

- Then obtain an optimal estimate of the state which minimizes the following estimated error covariance:

$$E[\underline{e}^T(t)\underline{e}(t)] = E[(\underline{x}(t) - \hat{\underline{x}}(t))^T(\underline{x}(t) - \hat{\underline{x}}(t))] \quad (6.100)$$

This leads to the Kalman-Bucy filter:

$$\frac{d}{dt}\hat{\underline{x}}(t) = \mathbf{A}\hat{\underline{x}}(t) + \mathbf{B}\underline{u}(t) + \mathbf{L}(\underline{y}(t) - \mathbf{C}\hat{\underline{x}}(t)) \quad (6.101)$$

And the stabilizing control $\underline{u}(t)$ now reads:

$$\underline{u}(t) = -\mathbf{K}\hat{\underline{x}}(t) \quad (6.102)$$

The observer gain \mathbf{L} reads:

$$\mathbf{L} = \mathbf{Y}\mathbf{C}^T\mathbf{P}_v^{-1} \quad (6.103)$$

where matrix $\mathbf{Y} = \mathbf{Y}^T > 0$ is the positive definite solution of the following algebraic Riccati equation

$$\mathbf{0} = \mathbf{A}\mathbf{Y} + \mathbf{Y}\mathbf{A}^T - \mathbf{Y}\mathbf{C}^T\mathbf{P}_v^{-1}\mathbf{C}\mathbf{Y} + \mathbf{P}_w \quad (6.104)$$

It is worth noticing that the optimal state estimate is independent of \mathbf{Q} and \mathbf{R} . Moreover the observer dynamics must be faster than the desired state-feedback dynamics.

Furthermore the dynamics of the state vector $\underline{x}(t)$ is slightly modified when compared with an actual state-feedback control $\underline{u}(t) = -\mathbf{K}\underline{x}(t)$. Indeed we have seen in (6.94) that the dynamics of the state vector $\underline{x}(t)$ is now modified and depends on $\underline{e}(t)$ and $\underline{w}(t)$:

$$\dot{\underline{x}}(t) = (\mathbf{A} - \mathbf{B}\mathbf{K})\underline{x}(t) + \mathbf{B}\mathbf{K}\underline{e}(t) + \underline{w}(t) \quad (6.105)$$

6.7 Controller transfer function

First let's assume that a full state-feedback $\underline{u}(t) = -\mathbf{K}\underline{x}(t)$ is applied on the following system:

$$\begin{cases} \dot{\underline{x}}(t) = \mathbf{A}\underline{x}(t) + \mathbf{B}\underline{u}(t) + \underline{w}(t) \\ \underline{y}(t) = \mathbf{C}\underline{x}(t) + \underline{v}(t) \end{cases} \quad (6.106)$$

Then the dynamics of the closed-loop system is given by:

$$\underline{u}(t) = -\mathbf{K}\underline{x}(t) \Rightarrow \dot{\underline{x}}(t) = (\mathbf{A} - \mathbf{B}\mathbf{K})\underline{x}(t) + \underline{w}(t) \quad (6.107)$$

If the full state vector $\underline{x}(t)$ is assumed not to be available the control $\underline{u}(t) = -\mathbf{K}\underline{x}(t)$ cannot be computed. Then an observer has to be added. We recall the dynamics of the observer (see (6.10)):

$$\dot{\hat{\underline{x}}}(t) = \mathbf{A}\hat{\underline{x}}(t) + \mathbf{B}\underline{u}(t) + \mathbf{L}(\underline{y}(t) - \mathbf{C}\hat{\underline{x}}(t)) \quad (6.108)$$

and the control $\underline{u}(t) = -\mathbf{K}\underline{x}(t)$ has to be changed into:

$$\underline{u}(t) = -\mathbf{K}\hat{\underline{x}}(t) \quad (6.109)$$

Gathering (6.108) and (6.109) leads to the state space representation of the controller:

$$\begin{bmatrix} \dot{\hat{\underline{x}}}(t) \\ \underline{u}(t) \end{bmatrix} = \begin{bmatrix} \mathbf{A}_K & | & \mathbf{B}_K \\ \mathbf{C}_K & | & \mathbf{D}_K \end{bmatrix} \begin{bmatrix} \hat{\underline{x}}(t) \\ \underline{y}(t) \end{bmatrix} \quad (6.110)$$

Where:

$$\begin{bmatrix} \mathbf{A}_K & | & \mathbf{B}_K \\ \mathbf{C}_K & | & \mathbf{D}_K \end{bmatrix} = \begin{bmatrix} \mathbf{A} - \mathbf{B}\mathbf{K} - \mathbf{L}\mathbf{C} & | & \mathbf{L} \\ -\mathbf{K} & | & \mathbf{0} \end{bmatrix} \quad (6.111)$$

The controller transfer function $\mathbf{K}(s)$ is the relation between the Laplace transform of its output, $\underline{U}(s)$, and the Laplace transform of its input, $\underline{Y}(s)$. By

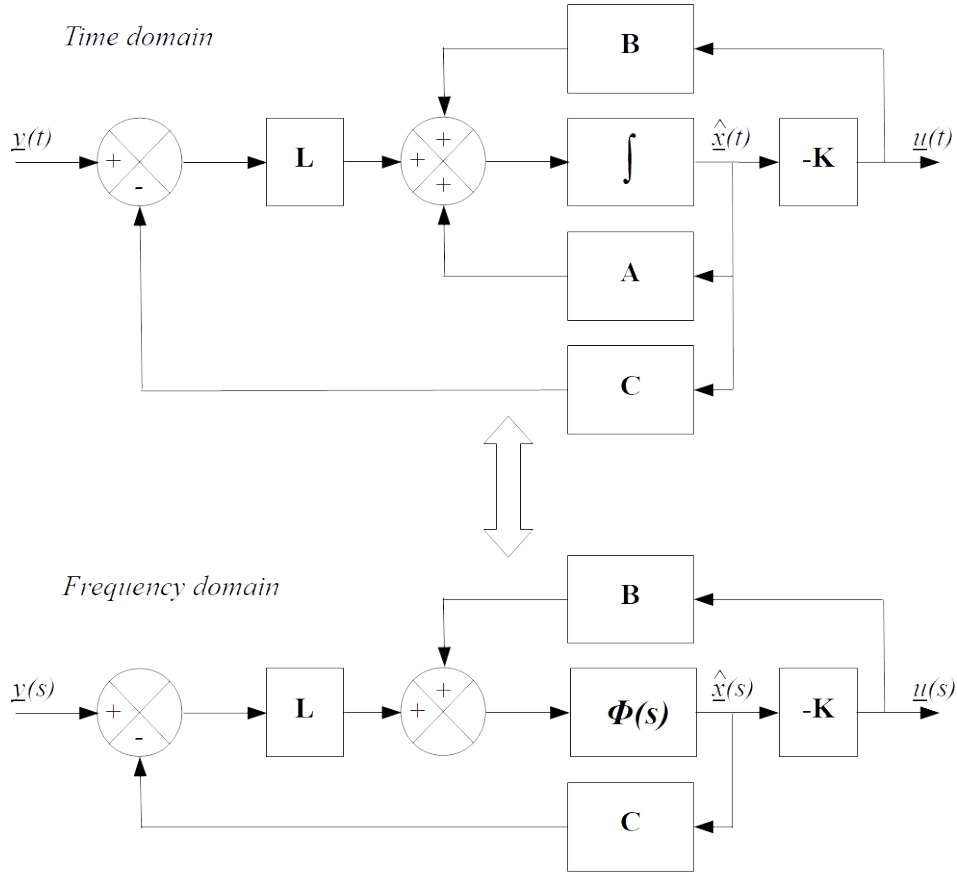

Figure 6.3: Block diagram of the controller in the time domain and the frequency domain

taking the Laplace transform of equation (6.108) and (6.109) (and assuming no initial condition) we get:

$$\begin{cases} s\hat{\underline{X}}(s) = \mathbf{A}\hat{\underline{X}}(s) + \mathbf{B}\underline{U}(s) + \mathbf{L}(\underline{Y}(s) - \mathbf{C}\hat{\underline{X}}(s)) \\ \underline{U}(s) = -\mathbf{K}\hat{\underline{X}}(s) \end{cases} \quad (6.112)$$

We finally get:

$$\underline{U}(s) = -\mathbf{K}(s)\underline{Y}(s) \quad (6.113)$$

where the controller transfer function $\mathbf{K}(s)$ reads:

$$\mathbf{K}(s) = \mathbf{K}(s\mathbf{I} - \mathbf{A} + \mathbf{B}\mathbf{K} + \mathbf{L}\mathbf{C})^{-1}\mathbf{L} \quad (6.114)$$

The preceding relation can be equivalently represented in the time domain or the frequency domain by the block diagram shown in Figure 6.3 where:

$$\Phi(s) := (s\mathbf{I} - \mathbf{A})^{-1} \quad (6.115)$$

6.8 Loop Transfer Recovery

6.8.1 Lack of guaranteed robustness of LQG design

According to the choice of matrix \mathbf{L} which drives the dynamics of the error $\underline{e}(t)$ the closed-loop may not be stable. So far LQR is shown to have either infinite gain margin (stable open-loop plant) or at least -6 dB gain margin and at least sixty degrees phase margin. In 1978 John Doyle² showed that all the nice robustness properties of LQR design can be lost once the observer is added and that LQG design can exhibit arbitrarily poor stability margins. Around 1981 Doyle along with Gunter Stein followed this line by showing that the loop shape itself will, in general, change when a filter is added for estimation. Fortunately there is a way of designing the Kalman-Bucy filter so that the full state-feedback properties are recovered at the input of the plant. This is the purpose of the Loop Transfer Recovery design. The LQG/LTR design method was introduced by Doyle and Stein in 1981 before the development of H_2 and H_∞ methods which is a more general approach to directly handle many types of modeling uncertainties.

6.8.2 Doyle's seminal example

Consider the following state space realization:

$$\begin{cases} \begin{bmatrix} \dot{x}_1(t) \\ \dot{x}_2(t) \end{bmatrix} = \begin{bmatrix} 1 & 1 \\ 0 & 1 \end{bmatrix} \begin{bmatrix} x_1(t) \\ x_2(t) \end{bmatrix} + \begin{bmatrix} 0 \\ 1 \end{bmatrix} \underline{u}(t) + \begin{bmatrix} 1 \\ 1 \end{bmatrix} \underline{w}(t) \\ y(t) = [1 \quad 0] \begin{bmatrix} x_1(t) \\ x_2(t) \end{bmatrix} + \underline{v}(t) \end{cases} \quad (6.116)$$

where $\underline{w}(t)$ and $\underline{v}(t)$ are Gaussian white noise with covariance matrices \mathbf{P}_w and \mathbf{P}_v , respectively:

$$\begin{cases} \mathbf{P}_w = \sigma \begin{bmatrix} 1 & 1 \\ 1 & 1 \end{bmatrix} \\ \sigma > 0 \\ \mathbf{P}_v = 1 \end{cases} \quad (6.117)$$

Let $J(\underline{u}(t))$ be the following cost functional to be minimized :

$$J(\underline{u}(t)) = \frac{1}{2} \int_0^\infty \underline{x}^T(t) \mathbf{Q} \underline{x}(t) + \underline{u}^T(t) \mathbf{R} \underline{u}(t) dt \quad (6.118)$$

where:

$$\begin{cases} \mathbf{Q} = q \begin{bmatrix} 1 & 1 \\ 1 & 1 \end{bmatrix} \\ q > 0 \\ \mathbf{R} = 1 \end{cases} \quad (6.119)$$

Applying the separation principle the optimal control law is achieved by adopting the following two steps procedure:

²Doyle J.C., Guaranteed margins for LQG regulators, IEEE Transactions on Automatic Control, Volume: 23, Issue: 4, Aug 1978

- First assume an exact measurement of the full state to solve the deterministic Linear Quadratic (LQ) control problem which minimizes the following cost functional $J(\underline{u}(t))$:

$$J(\underline{u}(t)) = \frac{1}{2} \int_0^\infty \underline{x}^T(t) \mathbf{Q} \underline{x}(t) + \underline{u}^T(t) \mathbf{R} \underline{u}(t) dt \quad (6.120)$$

This leads to the following stabilizing control $\underline{u}(t)$:

$$\underline{u}(t) = -\mathbf{K} \underline{x}(t) \quad (6.121)$$

Where the Kalman gain $\mathbf{K} = \mathbf{R}^{-1} \mathbf{B}^T \mathbf{P}$ is obtained thanks to the positive semi-definite solution \mathbf{P} of the following algebraic Riccati equation:

$$\mathbf{0} = \mathbf{A}^T \mathbf{P} + \mathbf{P} \mathbf{A} - \mathbf{P} \mathbf{B} \mathbf{R}^{-1} \mathbf{B}^T \mathbf{P} + \mathbf{Q} \quad (6.122)$$

We get:

$$\mathbf{P} = \begin{bmatrix} * & * \\ \alpha & \alpha \end{bmatrix} \quad (6.123)$$

And:

$$\mathbf{K} = \mathbf{R}^{-1} \mathbf{B}^T \mathbf{P} = \alpha \begin{bmatrix} 1 & 1 \end{bmatrix} \text{ where } \alpha = 2 + \sqrt{4+q} > 0 \quad (6.124)$$

- Then obtain an optimal estimate of the state which minimizes the following estimated error covariance :

$$E [\underline{e}^T(t) \underline{e}(t)] = E \left[(\underline{x}(t) - \hat{\underline{x}}(t))^T (\underline{x}(t) - \hat{\underline{x}}(t)) \right] \quad (6.125)$$

This leads to the Kalman-Bucy filter:

$$\frac{d}{dt} \hat{\underline{x}}(t) = \mathbf{A} \hat{\underline{x}}(t) + \mathbf{B} \underline{u}(t) + \mathbf{L}(t) (\underline{y}(t) - \mathbf{C} \hat{\underline{x}}(t)) \quad (6.126)$$

And the stabilizing control $\underline{u}(t)$ now reads:

$$\underline{u}(t) = -\mathbf{K} \hat{\underline{x}}(t) \quad (6.127)$$

The observer gain $\mathbf{L} = \mathbf{Y} \mathbf{C}^T \mathbf{P}_v^{-1}$ is obtained thanks to the positive semi-definite solution \mathbf{Y} of the following algebraic Riccati equation:

$$\mathbf{0} = \mathbf{A} \mathbf{Y} + \mathbf{Y} \mathbf{A}^T - \mathbf{Y} \mathbf{C}^T \mathbf{P}_v^{-1} \mathbf{C} \mathbf{Y} + \mathbf{P}_w \quad (6.128)$$

We get:

$$\mathbf{Y} = \begin{bmatrix} \beta & * \\ \beta & * \end{bmatrix} \quad (6.129)$$

And:

$$\mathbf{L} = \mathbf{Y} \mathbf{C}^T \mathbf{P}_v^{-1} = \beta \begin{bmatrix} 1 \\ 1 \end{bmatrix} \text{ where } \beta = 2 + \sqrt{4+\sigma} > 0 \quad (6.130)$$

Now assume that the input matrix of the plant is multiplied by a scalar gain Δ (nominally unit) :

$$\dot{\underline{x}}(t) = \mathbf{A}\underline{x}(t) + \Delta\mathbf{B}\underline{u}(t) + \begin{bmatrix} 1 \\ 1 \end{bmatrix} \underline{w}(t) \quad (6.131)$$

In order to assess the stability of the closed-loop system we will assume no exogenous disturbance $\underline{v}(t)$ and $\underline{w}(t)$. Then the dynamics of the closed-loop system reads:

$$\begin{bmatrix} \dot{\underline{x}}(t) \\ \dot{\hat{\underline{x}}}(t) \end{bmatrix} = \mathbf{A}_{cl} \begin{bmatrix} \underline{x}(t) \\ \hat{\underline{x}}(t) \end{bmatrix} \quad (6.132)$$

where, using (6.108) and (6.131):

$$\mathbf{A}_{cl} = \begin{bmatrix} \mathbf{A} & -\Delta\mathbf{BK} \\ \mathbf{LC} & \mathbf{A} - \mathbf{BK} - \mathbf{LC} \end{bmatrix} = \begin{bmatrix} 1 & 1 & 0 & 0 \\ 0 & 1 & -\Delta\alpha & -\Delta\alpha \\ \beta & 0 & 1 - \beta & 1 \\ \beta & 0 & -\alpha - \beta & 1 - \alpha \end{bmatrix} \quad (6.133)$$

The characteristic equation of the closed-loop system is:

$$\det(s\mathbb{I} - \mathbf{A}_{cl}) = s^4 + p_3s^3 + p_2s^2 + p_1s + p_0 = 0 \quad (6.134)$$

The evaluation of coefficients p_3 , p_2 , p_1 and p_0 is quite tedious. Nevertheless coefficient p_0 reads;

$$p_0 = 1 + (1 - \Delta)\alpha\beta \quad (6.135)$$

The closed-loop system is unstable if:

$$p_0 < 0 \Leftrightarrow \Delta > 1 + \frac{1}{\alpha\beta} \quad (6.136)$$

With large values of α and β even a slight increase in the value of Δ from its nominal value will render the closed-loop system to be unstable. Thus the phase margin of the LQG control-loop can be almost 0. This example clearly shows that the robustness of the LQG control-loop to modeling uncertainty is not guaranteed.

6.8.3 Closed-loop eigenvalues and eigenvectors

Let λ be a closed-loop eigenvalue and \underline{v} the corresponding eigenvector of the LQ state-feedback:

$$\begin{aligned} (\lambda\mathbb{I} - (\mathbf{A} - \mathbf{BK}))\underline{v} &= \underline{0} \text{ where } \mathbf{K} = \mathbf{R}^{-1}\mathbf{B}^T\mathbf{P} \\ \Leftrightarrow \lambda\underline{v} - \mathbf{A}\underline{v} + \mathbf{B}\mathbf{R}^{-1}\mathbf{B}^T\mathbf{P}\underline{v} &= \underline{0} \end{aligned} \quad (6.137)$$

Thus we can equivalently write:

$$\begin{bmatrix} \lambda\mathbb{I} - \mathbf{A} & \mathbf{B}\mathbf{R}^{-1}\mathbf{B}^T \end{bmatrix} \begin{bmatrix} \underline{v} \\ \mathbf{P}\underline{v} \end{bmatrix} = \underline{0} \quad (6.138)$$

Furthermore we have seen that matrix \mathbf{P} is the positive semi-definite solution of the following algebraic Riccati equation:

$$\mathbf{A}^T \mathbf{P} + \mathbf{P} \mathbf{A} - \mathbf{P} \mathbf{B} \mathbf{R}^{-1} \mathbf{B}^T \mathbf{P} + \mathbf{Q} = \mathbf{0} \quad (6.139)$$

Thus, multiplying this equality by eigenvector $-\underline{v}$, and adding and subtracting $\lambda \mathbf{P} \underline{v}$, we get:

$$\begin{aligned} & (-\mathbf{A}^T \mathbf{P} - \mathbf{P} \mathbf{A} + \mathbf{P} \mathbf{B} \mathbf{R}^{-1} \mathbf{B}^T \mathbf{P} - \mathbf{Q}) \underline{v} + \lambda \mathbf{P} \underline{v} - \lambda \mathbf{P} \underline{v} = \mathbf{0} \\ \Leftrightarrow & \mathbf{P} (\lambda \mathbb{I} - \mathbf{A} + \mathbf{B} \mathbf{R}^{-1} \mathbf{B}^T \mathbf{P}) \underline{v} - (\mathbf{Q} + \lambda \mathbf{P} + \mathbf{A}^T \mathbf{P}) \underline{v} = \mathbf{0} \end{aligned} \quad (6.140)$$

Inserting (6.137) within (6.140) yields:

$$\begin{aligned} & (\lambda \mathbb{I} - \mathbf{A} + \mathbf{B} \mathbf{R}^{-1} \mathbf{B}^T \mathbf{P}) \underline{v} = \underline{0} \Rightarrow (\mathbf{Q} + \lambda \mathbf{P} + \mathbf{A}^T \mathbf{P}) \underline{v} = \mathbf{0} \\ \Leftrightarrow & \begin{bmatrix} \mathbf{Q} & \lambda \mathbb{I} + \mathbf{A}^T \end{bmatrix} \begin{bmatrix} \underline{v} \\ \mathbf{P} \underline{v} \end{bmatrix} = \underline{0} \end{aligned} \quad (6.141)$$

Finally, (6.138) and (6.141) together read:

$$\begin{aligned} & \begin{bmatrix} \lambda \mathbb{I} - \mathbf{A} & \mathbf{B} \mathbf{R}^{-1} \mathbf{B}^T \\ \mathbf{Q} & \lambda \mathbb{I} + \mathbf{A}^T \end{bmatrix} \begin{bmatrix} \underline{v} \\ \mathbf{P} \underline{v} \end{bmatrix} = \underline{0} \\ \Leftrightarrow & \left(\lambda \mathbb{I} - \begin{bmatrix} \mathbf{A} & -\mathbf{B} \mathbf{R}^{-1} \mathbf{B}^T \\ -\mathbf{Q} & -\mathbf{A}^T \end{bmatrix} \right) \begin{bmatrix} \underline{v} \\ \mathbf{P} \underline{v} \end{bmatrix} = \underline{0} \end{aligned} \quad (6.142)$$

The preceding relation indicates the equivalence between any closed-loop eigenvalue λ and the corresponding eigenvector \underline{v} of the LQ state-feedback correspond and any eigenvalue of the Hamiltonian matrix $\mathbf{H} := \begin{bmatrix} \mathbf{A} & -\mathbf{B} \mathbf{R}^{-1} \mathbf{B}^T \\ -\mathbf{Q} & -\mathbf{A}^T \end{bmatrix}$ and the corresponding eigenvector $\begin{bmatrix} \underline{v} \\ \mathbf{P} \underline{v} \end{bmatrix}$ where matrix \mathbf{P} is the positive semi-definite solution of the algebraic Riccati equation.

6.8.4 Asymptotic behavior of Riccati equation

Now, let \mathbf{W} be some unitary matrix ($\mathbf{W}^T \mathbf{W} = \mathbb{I}$) and \mathbf{M} be some symmetric positive definite matrix ($\mathbf{M} = \mathbf{M}^T > 0$) such that $\mathbf{R} = \epsilon^2 \mathbf{M}$. Then if the transfer function $\mathbf{C} \Phi(s) \mathbf{B}$ is right invertible with no unstable zeros the following relation holds:

$$\begin{cases} \mathbf{R} = \epsilon^2 \mathbf{M} \\ \mathbf{Q} = \mathbf{C}^T \mathbf{C} \\ \mathbf{K} = \mathbf{R}^{-1} \mathbf{B}^T \mathbf{P} \end{cases} \Rightarrow \lim_{\epsilon \rightarrow 0} \mathbf{K} = \frac{1}{\epsilon} \mathbf{M}^{-0.5} \mathbf{W} \mathbf{C} = \mathbf{R}^{-0.5} \mathbf{W} \mathbf{C} \quad (6.143)$$

Indeed, the algebraic Riccati equation becomes in that case:

$$\begin{aligned} & \begin{cases} \mathbf{R} = \epsilon^2 \mathbf{M} = (\epsilon \mathbf{M}^{0.5})^T (\epsilon \mathbf{M}^{0.5}) \\ \mathbf{Q} = \mathbf{C}^T \mathbf{C} = \mathbf{C}^T \mathbf{W}^T \mathbf{W} \mathbf{C} = (\mathbf{W} \mathbf{C})^T (\mathbf{W} \mathbf{C}) \end{cases} \\ \Rightarrow \mathbf{0} & = \mathbf{A}^T \mathbf{P} + \mathbf{P} \mathbf{A} - \mathbf{P} \mathbf{B} \mathbf{R}^{-1} \mathbf{B}^T \mathbf{P} + \mathbf{Q} \\ & = \mathbf{A}^T \mathbf{P} + \mathbf{P} \mathbf{A} - \mathbf{P} \mathbf{B} \frac{\mathbf{M}^{-1}}{\epsilon^2} \mathbf{B}^T \mathbf{P} + (\mathbf{W} \mathbf{C})^T (\mathbf{W} \mathbf{C}) \\ & = \mathbf{A}^T \mathbf{P} + \mathbf{P} \mathbf{A} - \left(\frac{\mathbf{M}^{-0.5}}{\epsilon} \mathbf{B}^T \mathbf{P} \right)^T \left(\frac{\mathbf{M}^{-0.5}}{\epsilon} \mathbf{B}^T \mathbf{P} \right) + (\mathbf{W} \mathbf{C})^T (\mathbf{W} \mathbf{C}) \end{aligned} \quad (6.144)$$

If the transfer function $\mathbf{C}\Phi(s)\mathbf{B}$ is right invertible with no unstable zeros then $\mathbf{P} \rightarrow \mathbf{0}$ as $\epsilon \rightarrow 0$ and the preceding equation reads as follows, where $\mathbf{A}^T\mathbf{P} + \mathbf{P}\mathbf{A}$ has been neglected:

$$\begin{aligned} \mathbf{0} &\underset{\epsilon \rightarrow 0}{\approx} - \left(\frac{\mathbf{M}^{-0.5}}{\epsilon} \mathbf{B}^T \mathbf{P} \right)^T \left(\frac{\mathbf{M}^{-0.5}}{\epsilon} \mathbf{B}^T \mathbf{P} \right) + (\mathbf{W}\mathbf{C})^T (\mathbf{W}\mathbf{C}) \\ &\Rightarrow \frac{\mathbf{M}^{-0.5}}{\epsilon} \mathbf{B}^T \mathbf{P} \underset{\epsilon \rightarrow 0}{\approx} \mathbf{W}\mathbf{C} \end{aligned} \quad (6.145)$$

We finally get, using the fact that $\mathbf{R} = \epsilon^2\mathbf{M}$:

$$\mathbf{K} = \mathbf{R}^{-1}\mathbf{B}^T\mathbf{P} = \frac{1}{\epsilon}\mathbf{M}^{-0.5}\frac{\mathbf{M}^{-0.5}}{\epsilon}\mathbf{B}^T\mathbf{P} \underset{\epsilon \rightarrow 0}{\approx} \frac{1}{\epsilon}\mathbf{M}^{-0.5}\mathbf{W}\mathbf{C} = \mathbf{R}^{-0.5}\mathbf{W}\mathbf{C} \quad (6.146)$$

This completes the proof. ■

6.8.5 Loop Transfer Recovery (LTR) design

Linear Quadratic (LQ) controller and the Kalman-Bucy filter (KF) alone have very good robustness property. Nevertheless we have seen with Doyle's seminal example that Linear Quadratic Gaussian (LQG) control which simultaneously involves a Linear Quadratic (LQ) controller and a Kalman-Bucy filter (KF) does not have any guaranteed robustness. Therefore the LQG / LTR design tries to recover a target open-loop transfer function. The target loop transfer function is either:

- the Linear Quadratic (LQ) control open-loop transfer function, which is $\mathbf{K}\Phi(s)\mathbf{B}$
- or the Kalman-Bucy filter (KF) open-loop transfer function, which is $\mathbf{C}\Phi(s)\mathbf{L}$.

Let ρ be a parameter design of either design matrix \mathbf{Q} or matrix \mathbf{P}_w and $\mathbf{F}(s)$ the transfer function of the plant:

$$\mathbf{F}(s) = \mathbf{C}\Phi(s)\mathbf{B} \quad (6.147)$$

Then two types of Loop Transfer Recovery are possible:

- Input recovery: let ω_c be the cut-off frequency (i.e. 0 dB) of the targeted dynamics. The objective is to tune ρ such that:

$$\lim_{\rho \rightarrow \infty} \mathbf{K}(s)\mathbf{F}(s) \Big|_{\substack{s = j\omega \\ \omega < \omega_c}} \approx \mathbf{K}\Phi(s)\mathbf{B} \Big|_{\substack{s = j\omega \\ \omega < \omega_c}} \quad (6.148)$$

The objective of the input recovery design is shown in Figure 6.4. The corresponding objective in the state space domain is the following:

$$\begin{cases} \dot{\mathbf{x}}(t) = \mathbf{A}\mathbf{x}(t) + \mathbf{B}\mathbf{u}(t) \\ \mathbf{u}(t) = -\mathbf{K}\mathbf{x}(t) + \mathbf{r}(t) \end{cases} \quad (6.149)$$

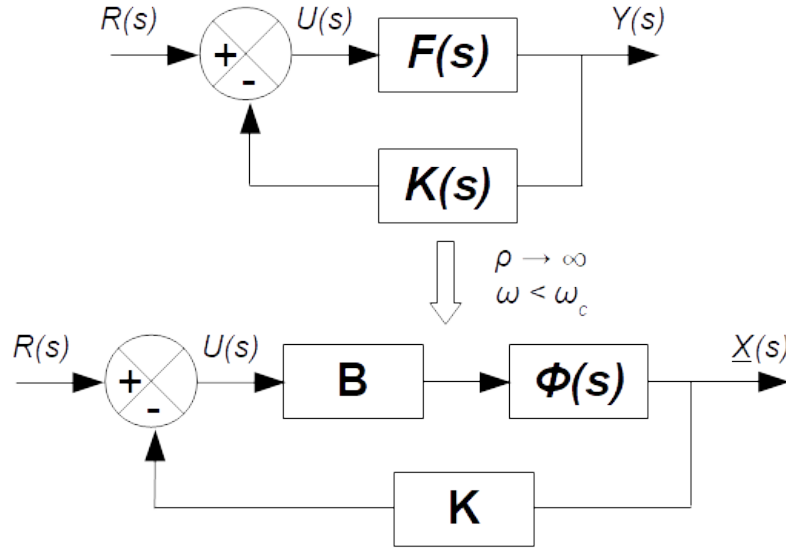

Figure 6.4: Input recovery objective

- Output recovery: let ω_c be the cut-off frequency (i.e. 0 dB) of the targeted dynamics. The objective is to tune ρ such that:

$$\lim_{\rho \rightarrow \infty} \mathbf{F}(s)\mathbf{K}(s) \Big|_{\substack{s = j\omega \\ \omega < \omega_c}} \approx \mathbf{C}\Phi(s)\mathbf{L} \Big|_{\substack{s = j\omega \\ \omega < \omega_c}} \quad (6.150)$$

The objective of the output recovery design is shown in Figure 6.5³. The corresponding objective in the state space domain is the following:

$$\begin{cases} \dot{\hat{\mathbf{x}}}(t) = \mathbf{A}\hat{\mathbf{x}}(t) + \mathbf{L}(r(t) - \hat{\mathbf{y}}(t)) \\ \hat{\mathbf{y}}(t) = \mathbf{C}\hat{\mathbf{x}}(t) \end{cases} \quad (6.151)$$

We recall that initial design matrices \mathbf{Q}_0 and \mathbf{R}_0 are set to meet control requirements whereas initial design matrices \mathbf{P}_{w0} and \mathbf{P}_{v0} are set to meet observer requirements. Let ρ be a parameter design of either design matrix \mathbf{P}_w or matrix \mathbf{Q} . Weighting parameter ρ is tuned to make a trade-off between initial performances and stability margins and is set according to the type of Loop Transfer Recovery:

- Input recovery: a new observer design with the following design matrices:

$$\begin{cases} \mathbf{P}_w = \mathbf{P}_{w0} + \rho^2 \mathbf{B}\mathbf{B}^T \\ \mathbf{P}_v = \mathbf{P}_{v0} \end{cases} \quad (6.152)$$

³Ronaldo Waschburger and Karl Heinz Kienitz, A root locus approach to loop transfer recovery based controller design, 13th International Conference on Control Automation Robotics & Vision (ICARCV), 2014

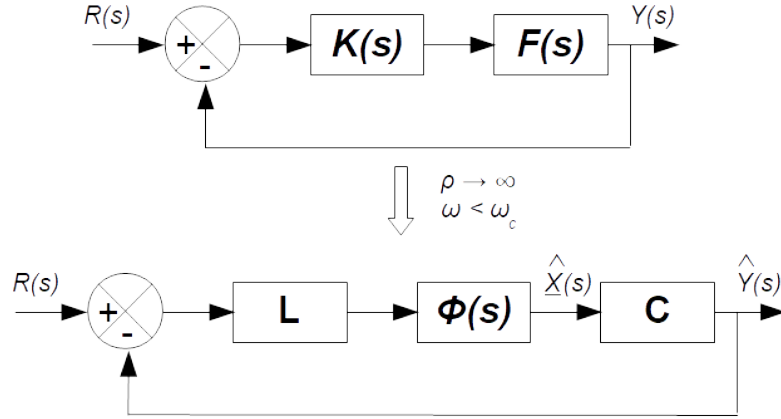

Figure 6.5: Output recovery objective

- Output recovery: a new controller is designed with the following design matrices:

$$\begin{cases} \mathbf{Q} = \mathbf{Q}_0 + \rho^2 \mathbf{C}^T \mathbf{C} \\ \mathbf{R} = \mathbf{R}_0 \end{cases} \quad (6.153)$$

The preceding relation is simply obtained by applying the duality principle.

From a practical point of view, design parameter ρ is increased until satisfactory robust properties of the loop transfer function are achieved. It is worth noticing that to apply Loop Transfer Recovery (LTR) the transfer function $\mathbf{C}\Phi(s)\mathbf{B}$ shall be minimum phase (i.e. no zero with positive real part) and square (meaning that the system has the same number of inputs and outputs).

Example 6.2. *Let's the double integrator plant:*

$$\begin{cases} \mathbf{A} = \begin{bmatrix} 0 & 1 \\ 0 & 0 \end{bmatrix} \\ \mathbf{B} = \begin{bmatrix} 0 \\ 1 \end{bmatrix} \\ \mathbf{C} = \begin{bmatrix} 1 & 0 \end{bmatrix} \end{cases} \quad (6.154)$$

Let:

$$\begin{cases} \mathbf{K} = \begin{bmatrix} k_1 & k_2 \end{bmatrix} \\ \mathbf{L} = \begin{bmatrix} l_1 \\ l_2 \end{bmatrix} \end{cases} \quad (6.155)$$

Then the controller transfer function is given by (6.114):

$$\begin{aligned} \mathbf{K}(s) &= \mathbf{K} (s\mathbb{I} - \mathbf{A} + \mathbf{BK} + \mathbf{LC})^{-1} \mathbf{L} \\ &= \begin{bmatrix} k_1 & k_2 \end{bmatrix} \begin{bmatrix} s + l_1 & -1 \\ k_1 + l_2 & s + k_2 \end{bmatrix}^{-1} \begin{bmatrix} l_1 \\ l_2 \end{bmatrix} \\ &= \frac{(k_1 l_1 + k_2 l_2) s + k_1 l_2}{s^2 + (k_2 + l_1) s + k_2 l_1 + k_1 + l_2} \end{aligned} \quad (6.156)$$

From (6.153) we set \mathbf{Q} and \mathbf{R} as follows:

$$\begin{cases} \mathbf{Q}_0 := \mathbf{0} \\ \mathbf{Q} = \mathbf{Q}_0 + \rho^2 \mathbf{C}^T \mathbf{C} \Rightarrow \mathbf{Q} = \rho^2 \mathbf{C}^T \mathbf{C} = \begin{bmatrix} \rho^2 & 0 \\ 0 & 0 \end{bmatrix} \\ \mathbf{R} = \mathbf{R}_0 := 1 \end{cases} \quad (6.157)$$

The Kalman gain $\mathbf{K} = \mathbf{R}^{-1} \mathbf{B}^T \mathbf{P}$ is then obtained thanks to the positive semi-definite solution \mathbf{P} of the following algebraic Riccati equation:

$$\begin{aligned} \mathbf{0} &= \mathbf{A}^T \mathbf{P} + \mathbf{P} \mathbf{A} - \mathbf{P} \mathbf{B} \mathbf{R}^{-1} \mathbf{B}^T \mathbf{P} + \mathbf{Q} \Rightarrow \mathbf{P} = \begin{bmatrix} * & * \\ \rho & \sqrt{2\rho} \end{bmatrix} \\ \Rightarrow \mathbf{K} &= \mathbf{R}^{-1} \mathbf{B}^T \mathbf{P} = \begin{bmatrix} \rho & \sqrt{2\rho} \end{bmatrix} := \begin{bmatrix} k_1 & k_2 \end{bmatrix} \end{aligned} \quad (6.158)$$

Consequently:

$$\begin{aligned} \lim_{\rho \rightarrow \infty} \mathbf{K}(s) &= \lim_{\rho \rightarrow \infty} \frac{(k_1 l_1 + k_2 l_2) s + k_1 l_2}{s^2 + (k_2 + l_1) s + k_2 l_1 + k_1 + l_2} \\ &= \lim_{\rho \rightarrow \infty} \frac{(\rho l_1 + \sqrt{2\rho} l_2) s + \rho l_2}{s^2 + (\sqrt{2\rho} + l_1) s + \sqrt{2\rho} l_1 + \rho + l_2} \\ &= \lim_{\rho \rightarrow \infty} \frac{\rho l_1 s + \rho l_2}{\rho} \\ &= l_1 s + l_2 \end{aligned} \quad (6.159)$$

The transfer function of the plant reads:

$$\mathbf{F}(s) = \mathbf{C} \Phi(s) \mathbf{B} = \mathbf{C} (s\mathbb{I} - \mathbf{A})^{-1} \mathbf{B} = \frac{1}{s^2} \quad (6.160)$$

Therefore:

$$\lim_{\rho \rightarrow \infty} \mathbf{K}(s) \mathbf{F}(s) = \frac{l_1 s + l_2}{s^2} \quad (6.161)$$

Note that:

$$\mathbf{C} \Phi(s) \mathbf{L} = \frac{l_1 s + l_2}{s^2} \quad (6.162)$$

Therefore the loop transfer function has been recovered. ■

6.9 Proof of the Loop Transfer Recovery condition

6.9.1 Loop transfer function with observer

The Loop Transfer Recovery design procedure tries to recover a target loop transfer function, here the open-loop full state LQ control, despite the use of the observer.

The lecture of Faryar Jabbari, from the Henry Samueli School of Engineering, University of California, is the primary source of this section⁴.

We will first show what happen when adding an observer-based closed-loop on the following system where $\underline{y}(t)$ is the *actual* output of the system (not the *controlled* output):

$$\begin{cases} \dot{\underline{x}}(t) = \mathbf{A} \underline{x}(t) + \mathbf{B} \underline{u}(t) \\ \underline{y}(t) = \mathbf{C} \underline{x}(t) \end{cases} \quad (6.163)$$

⁴<http://mae2.eng.uci.edu/~fjabbari/me270b/chap9.pdf>

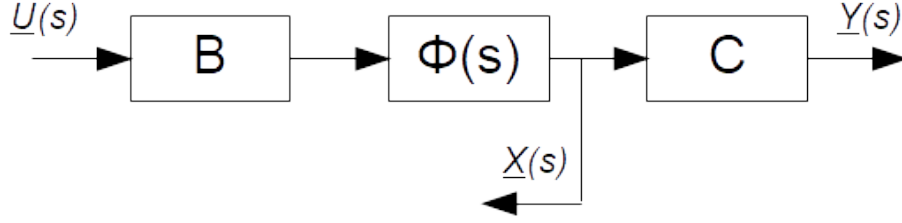

Figure 6.6: Block diagram of open-loop transfer function

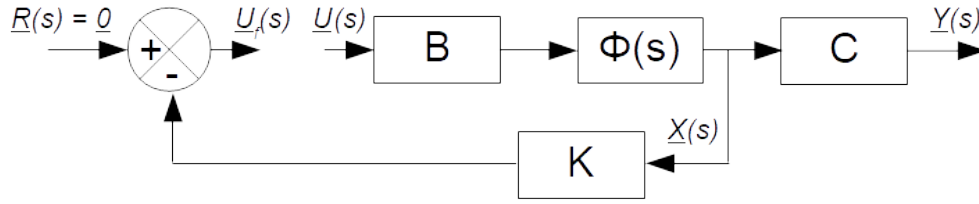

Figure 6.7: Broken state-feedback loop

Taking the Laplace transform and assuming no initial condition, we get:

$$\begin{cases} s\underline{X}(s) = \mathbf{A}\underline{X}(s) + \mathbf{B}\underline{U}(s) \\ \underline{Y}(s) = \mathbf{C}\underline{X}(s) \end{cases} \Rightarrow \begin{cases} \underline{X}(s) = \Phi(s)\mathbf{B}\underline{U}(s) \\ \underline{Y}(s) = \mathbf{C}\underline{X}(s) \end{cases} \quad (6.164)$$

where:

$$\Phi(s) = (s\mathbb{I} - \mathbf{A})^{-1} \quad (6.165)$$

The preceding relations can be represented by the block diagram in Figure 6.6. Let \mathbf{K} be a full state-feedback gain matrix such that the closed-loop system is asymptotically stable, i.e. the eigenvalues of $\mathbf{A} - \mathbf{B}\mathbf{K}$ lie in the left half s -plane, and the open-loop transfer function when the loop is broken at the input point of the given system meets some given frequency dependent specifications. The state feedback control \underline{u}_f with full state available is:

$$\underline{u}_f(t) = -\mathbf{K}\underline{x}(t) \Leftrightarrow \underline{U}_f(s) = -\mathbf{K}\underline{X}(s) \quad (6.166)$$

We will focus on the regulator problem and thus $\underline{r} = \underline{0}$. As shown in Figure 6.7 the loop transfer function is evaluated when the loop is broken at the input point of the system. The so-called target loop transfer function $\mathbf{L}_t(s)$ is defined as follows:

$$\underline{U}_f(s) = \mathbf{L}_t(s)\underline{U}(s) \quad \text{where} \quad \mathbf{L}_t(s) = -\mathbf{K}\Phi(s)\mathbf{B} \quad (6.167)$$

If the full state vector $\underline{x}(t)$ is assumed not to be available, the control $\underline{u}(t) = -\mathbf{K}\underline{x}(t)$ cannot be computed. We then add an observer with the following expression:

$$\hat{\underline{x}}(t) = \mathbf{A}\hat{\underline{x}}(t) + \mathbf{B}\underline{u}(t) + \mathbf{L}(y(t) - \mathbf{C}\hat{\underline{x}}(t)) \quad (6.168)$$

The observer-based state-feedback control \underline{u}_o is:

$$\underline{u}_o(t) = -\mathbf{K}\hat{\underline{x}}(t) \quad (6.169)$$

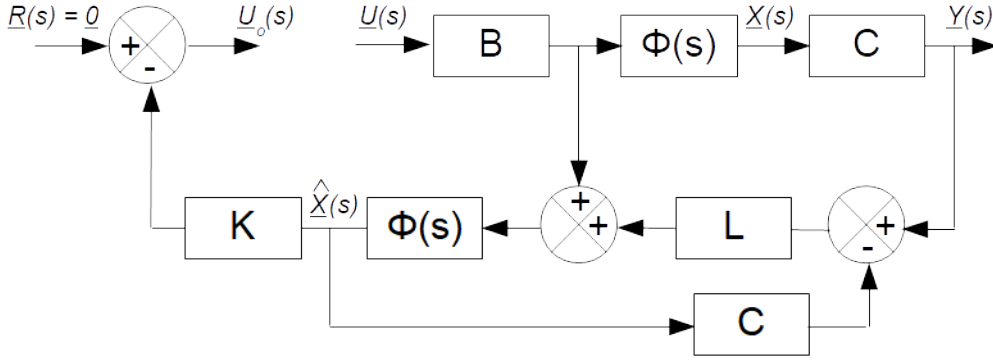

Figure 6.8: Broken observer-based feedback loop

Taking the Laplace transform results in:

$$\begin{cases} s\hat{X}(s) = \mathbf{A}\hat{X}(s) + \mathbf{B}U(s) + \mathbf{L}(Y(s) - \mathbf{C}\hat{X}(s)) \\ \underline{U}_o(s) = -\mathbf{K}\hat{X}(s) \end{cases} \quad (6.170)$$

or, equivalently:

$$\begin{cases} \hat{X}(s) = (s\mathbb{I} - \mathbf{A})^{-1} (\mathbf{B}U(s) + \mathbf{L}(Y(s) - \mathbf{C}\hat{X}(s))) \\ \underline{U}_o(s) = -\mathbf{K}\hat{X}(s) \end{cases} \quad (6.171)$$

Usually equation (6.171) is not the same than (6.166). Relation (6.171) can be represented by the block diagram in Figure 6.8. The loop transfer function evaluated when the loop is broken at the input point of the closed-loop system becomes:

$$\begin{aligned} \begin{cases} \hat{X}(s) = (\Phi(s)^{-1} + \mathbf{LC})^{-1} (\mathbf{B}U(s) + \mathbf{L}Y(s)) \\ Y(s) = \mathbf{C}\Phi(s)\mathbf{B}U(s) \end{cases} \\ \Rightarrow \hat{X}(s) = (\Phi(s)^{-1} + \mathbf{LC})^{-1} (\mathbf{B}U(s) + \mathbf{LC}\Phi(s)\mathbf{B}U(s)) \\ = (\Phi(s)^{-1} + \mathbf{LC})^{-1} (\mathbf{B} + \mathbf{LC}\Phi(s)\mathbf{B})U(s) \\ = (\Phi(s)^{-1} + \mathbf{LC})^{-1} \mathbf{B}U(s) \\ \quad + (\Phi(s)^{-1} + \mathbf{LC})^{-1} \mathbf{LC}\Phi(s)\mathbf{B}U(s) \end{aligned} \quad (6.172)$$

Finally, the actual loop transfer function $\mathbf{L}_a(s)$ reads as follows:

$$\underline{U}_o(s) = \mathbf{L}_a(s)\underline{U}(s) \quad \text{where } \mathbf{L}_a(s) = -\mathbf{K}(\Phi(s)^{-1} + \mathbf{LC})^{-1}(\mathbf{B} + \mathbf{LC}\Phi(s))\mathbf{B} \quad (6.173)$$

6.9.2 Loop Transfer Recovery (LTR) condition

Loop Transfer Recovery (LTR) will be achieved when the loop transfer function with state-feedback and with state-based observer are equal, that is when $\mathbf{L}_a(s) = \mathbf{L}_t(s)$, where loop transfer functions $\mathbf{L}_t(s)$ and $\mathbf{L}_a(s)$ are given by (6.167) and (6.173) respectively.

We finally get:

$$\underline{U}_o(s) = -\mathbf{K}\widehat{\mathbf{X}}(s) = -\mathbf{K}\Phi(s)\mathbf{B}\underline{U}(s) \quad (6.184)$$

That is, we get for $\underline{U}_o(s)$ the same expression than the expression obtained through the full state-feedback given in (6.166).

As a conclusion, the Loop Transfer Recovery (LTR) is achieved when the loop transfer function with state-feedback and with state-based observer are equal, that is when $\mathbf{L}_a(s) = \mathbf{L}_t(s)$. This property is achieved as soon as $\underline{U}_o(s)$ has the same expression as the full state-feedback $\underline{U}_f(s)$, that is when the following relation holds:

$$\boxed{\mathbf{L}(\mathbb{I} + \mathbf{C}\Phi(s)\mathbf{L})^{-1} = \mathbf{B}(\mathbf{C}\Phi(s)\mathbf{B})^{-1}} \quad (6.185)$$

6.9.3 Setting the Loop Transfer Recovery design parameter

Condition (6.185) is not an easy condition to satisfy. The traditional approaches to this problem is to design matrix \mathbf{L} of the observer such that the condition is satisfied asymptotically and ρ a design parameter.

One way to asymptotically satisfy (6.185) is to set \mathbf{L} such that:

$$\lim_{\rho \rightarrow \infty} \frac{\mathbf{L}}{\rho} = \mathbf{B}\mathbf{W}_0 \quad (6.186)$$

where \mathbf{W}_0 is a non-singular matrix.

Indeed in this case we have:

$$\begin{aligned} \mathbf{L}(\mathbb{I} + \mathbf{C}\Phi(s)\mathbf{L})^{-1} &= \frac{\mathbf{L}}{\rho}\rho(\mathbb{I} + \mathbf{C}\Phi(s)\mathbf{L})^{-1} \\ &= \frac{\mathbf{L}}{\rho} \left(\frac{1}{\rho}\mathbb{I} + \mathbf{C}\Phi(s)\frac{\mathbf{L}}{\rho} \right)^{-1} \end{aligned} \quad (6.187)$$

Thus, as $\rho \rightarrow \infty$:

$$\begin{aligned} \lim_{\rho \rightarrow \infty} \mathbf{L}(\mathbb{I} + \mathbf{C}\Phi(s)\mathbf{L})^{-1} &= \lim_{\rho \rightarrow \infty} \frac{\mathbf{L}}{\rho} \left(\frac{1}{\rho}\mathbb{I} + \mathbf{C}\Phi(s)\frac{\mathbf{L}}{\rho} \right)^{-1} \\ &= \lim_{\rho \rightarrow \infty} \frac{\mathbf{L}}{\rho} \left(\mathbf{C}\Phi(s)\frac{\mathbf{L}}{\rho} \right)^{-1} \\ &= \mathbf{B}\mathbf{W}_0 (\mathbf{C}\Phi(s)\mathbf{B}\mathbf{W}_0)^{-1} \\ &= \mathbf{B}(\mathbf{C}\Phi(s)\mathbf{B})^{-1} \end{aligned} \quad (6.188)$$

Now let's concentrate how (6.186) can be achieved. First we have seen in (6.143) that if the transfer function $\mathbf{C}\Phi(s)\mathbf{B}$ is right invertible with no unstable zeros then for some unitary matrix \mathbf{W} ($\mathbf{W}^T\mathbf{W} = \mathbb{I}$) and some symmetric positive definite matrix \mathbf{M} ($\mathbf{M} = \mathbf{M}^T > 0$), the asymptotic value of feedback gain \mathbf{K} reads as follows, where ϵ has been replaced by $\frac{1}{\rho}$:

$$\begin{cases} \mathbf{R} = \frac{\mathbf{M}}{\rho^2} \\ \mathbf{Q} = \mathbf{C}^T\mathbf{C} \\ \mathbf{K} = \mathbf{R}^{-1}\mathbf{B}^T\mathbf{P} \end{cases} \Rightarrow \lim_{\rho \rightarrow \infty} \mathbf{K} = \rho\mathbf{M}^{-0.5}\mathbf{W}\mathbf{C} = \mathbf{R}^{-0.5}\mathbf{W}\mathbf{C} \quad (6.189)$$

Applying the duality principle we have the same result for the asymptotic value of the observer gain \mathbf{L} :

$$\begin{cases} \mathbf{P}_v = \frac{\mathbf{M}}{\rho^2} \\ \mathbf{P}_w = \mathbf{B}\mathbf{B}^T \\ \mathbf{L} = \mathbf{Y}\mathbf{C}^T\mathbf{P}_v^{-1} \end{cases} \Rightarrow \lim_{\rho \rightarrow \infty} \mathbf{L} = \rho\mathbf{B}\mathbf{W}\mathbf{M}^{-0.5} = \mathbf{B}\mathbf{W}\mathbf{P}_v^{-0.5} \quad (6.190)$$

Then, we concentrate on input recovery (6.152). We design a new observer with the following design matrices:

$$\begin{cases} \mathbf{P}_w = \mathbf{P}_{w0} + \rho^2\mathbf{B}\mathbf{B}^T \\ \mathbf{P}_v = \mathbf{P}_{v0} \end{cases} \quad (6.191)$$

Then if we replace \mathbf{P}_v by \mathbf{P}_{v0} and $\mathbf{P}_w = \mathbf{B}\mathbf{B}^T$ by $\mathbf{P}_w = \mathbf{P}_{w0} + \rho^2\mathbf{B}\mathbf{B}^T$ in (6.190), the asymptotic value of the observer gain \mathbf{L} reads as follows:

$$\begin{cases} \mathbf{P}_v = \mathbf{P}_{v0} \\ \mathbf{P}_w = \mathbf{P}_{w0} + \rho^2\mathbf{B}\mathbf{B}^T \\ \mathbf{L} = \mathbf{Y}\mathbf{C}^T\mathbf{P}_v^{-1} \end{cases} \Rightarrow \lim_{\rho \rightarrow \infty} \mathbf{L} = \rho\mathbf{B}\mathbf{W}\mathbf{P}_{v0}^{-0.5} \Rightarrow \lim_{\rho \rightarrow \infty} \frac{\mathbf{L}}{\rho} = \mathbf{B}\mathbf{W}\mathbf{P}_{v0}^{-0.5} \quad (6.192)$$

By setting $\mathbf{W}_0 := \mathbf{W}\mathbf{P}_{v0}^{-0.5}$ we finally get (6.186):

$$\lim_{\rho \rightarrow \infty} \frac{\mathbf{L}}{\rho} = \mathbf{B}\mathbf{W}_0 \quad (6.193)$$

6.10 Robust control design

Robust control problems, and especially H_2 robust control problems, are solved in a dedicated framework presented in Figure 6.9 where:

- $\mathbf{G}(s)$ is the transfer function of the *generalized* plant;
- $\mathbf{K}(s)$ is the transfer function of the controller ;
- \underline{u} is the control vector of the *generalized* plant $\mathbf{G}(s)$ which is computed by the controller $\mathbf{K}(s)$;
- \underline{w} is the input vector formed by *exogenous inputs* such as disturbances or noise;
- \underline{y} is the vector of output available for the controller $\mathbf{K}(s)$;
- \underline{z} is the performance output vector, also-called the *controlled* output, that is the vector that allows to characterize the performance of the closed-loop system. This is a *virtual* output used only for design that we wish to maintain as small as possible.

It is worth noticing that in the standard feedback control loop in Figure 6.9 *all reference signals are set to zero*.

The H_2 control problem consists in finding the optimal controller $\mathbf{K}(s)$ which minimizes $\|\mathbf{T}_{zw}(s)\|_2$, that is the H_2 norm of the transfer between the exogenous inputs vector \underline{w} and the vector of interest variables \underline{z} .

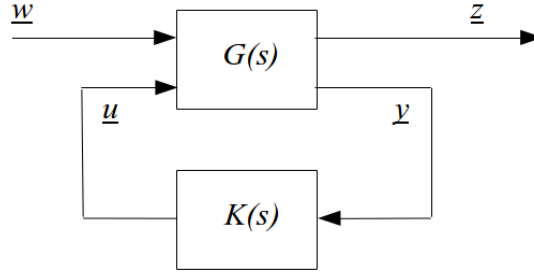

Figure 6.9: Standard feedback control loop

The general form of the realization of a plant is the following:

$$\begin{bmatrix} \dot{\underline{x}}(t) \\ \underline{z}(t) \\ \underline{y}(t) \end{bmatrix} = \begin{bmatrix} \mathbf{A} & \mathbf{B}_1 & \mathbf{B}_2 \\ \mathbf{C}_1 & \mathbf{0} & \mathbf{D}_{12} \\ \mathbf{C}_2 & \mathbf{D}_{21} & \mathbf{0} \end{bmatrix} \begin{bmatrix} \underline{x}(t) \\ \underline{w}(t) \\ \underline{u}(t) \end{bmatrix} \quad (6.194)$$

Linear-quadratic-Gaussian (LQG) control is a special case of H_2 optimal control applied to stochastic system.

Let's consider the following system realization:

$$\begin{cases} \dot{\underline{x}}(t) = \mathbf{A}\underline{x}(t) + \mathbf{B}_2\underline{u}(t) + \underline{d}(t) \\ \underline{y}(t) = \mathbf{C}_2\underline{x}(t) + \underline{n}(t) \end{cases} \quad (6.195)$$

Where $\underline{d}(t)$ and $\underline{n}(t)$ are white noise with the intensity of their autocorrelation function equals to \mathbf{W}_d and \mathbf{W}_n respectively. Denoting by $E(\cdot)$ the mathematical expectation we have:

$$E \left(\begin{bmatrix} \underline{d}(t) \\ \underline{n}(t) \end{bmatrix} \begin{bmatrix} \underline{d}^T(\tau) & \underline{n}^T(\tau) \end{bmatrix} \right) = \begin{bmatrix} \mathbf{W}_d & \mathbf{0} \\ \mathbf{0} & \mathbf{W}_n \end{bmatrix} \delta(t - \tau) \quad (6.196)$$

The LQG problem consists in finding a controller $\underline{u}(s) = \mathbf{K}(s)\underline{y}(s)$ such that the following performance index is minimized:

$$J_{LQG} = E \left(\lim_{T \rightarrow \infty} \int_0^T (\underline{x}^T(t)\mathbf{Q}\underline{x}(t) + \underline{u}^T(t)\mathbf{R}\underline{u}(t)) dt \right) \quad (6.197)$$

Where matrices \mathbf{Q} and \mathbf{R} are symmetric and (semi)-positive definite matrices:

$$\begin{cases} \mathbf{Q} = \mathbf{Q}^T \geq 0 \\ \mathbf{R} = \mathbf{R}^T > 0 \end{cases} \quad (6.198)$$

This problem can be cast as the H_2 optimal control framework in the following manner. Define signal $\underline{z}(t)$ whose norm is to be minimized as follows:

$$\underline{z}(t) = \begin{bmatrix} \mathbf{Q}^{0.5} & \mathbf{0} \\ \mathbf{0} & \mathbf{R}^{0.5} \end{bmatrix} \begin{bmatrix} \underline{x}(t) \\ \underline{u}(t) \end{bmatrix} \quad (6.199)$$

And represent the stochastic inputs $\underline{d}(t)$ and $\underline{n}(t)$ as a function of the vector $\underline{w}(t)$ of exogenous disturbances :

$$\begin{bmatrix} \underline{d}(t) \\ \underline{n}(t) \end{bmatrix} = \begin{bmatrix} \mathbf{W}_d^{0.5} & \mathbf{0} \\ \mathbf{0} & \mathbf{W}_n^{0.5} \end{bmatrix} \underline{w}(t) \quad (6.200)$$

Where $\underline{w}(t)$ is a white noise process of unit intensity. Then the LQG cost function reads as follows:

$$J_{LQG} = E \left(\lim_{T \rightarrow \infty} \int_0^T \underline{z}^T(t) \underline{z}(t) dt \right) = \|\mathbf{T}_{zw}(s)\|_2^2 \quad (6.201)$$

And the generalized plant reads as follows:

$$\begin{bmatrix} \dot{\underline{x}}(t) \\ \underline{z}(t) \\ \underline{y}(t) \end{bmatrix} = \begin{bmatrix} \mathbf{A} & \mathbf{B}_1 & \mathbf{B}_2 \\ \mathbf{C}_1 & \mathbf{0} & \mathbf{D}_{12} \\ \mathbf{C}_2 & \mathbf{D}_{21} & \mathbf{0} \end{bmatrix} \begin{bmatrix} \underline{x}(t) \\ \underline{w}(t) \\ \underline{u}(t) \end{bmatrix} \quad (6.202)$$

Where:

$$\begin{cases} \mathbf{B}_1 = [\mathbf{W}_d^{0.5} & \mathbf{0}] \\ \mathbf{C}_1 = [\mathbf{Q}^{0.5} \\ \mathbf{0}] \\ \mathbf{D}_{12} = [\mathbf{0} \\ \mathbf{R}^{0.5}] \\ \mathbf{D}_{21} = [\mathbf{0} & \mathbf{W}_n^{0.5}] \end{cases} \quad (6.203)$$

It follows that:

$$\begin{cases} \mathbf{B}_1 \underline{w}(t) = [\mathbf{W}_d^{0.5} & \mathbf{0}] \underline{w}(t) = \underline{d}(t) \\ \mathbf{D}_{21} \underline{w}(t) = [\mathbf{0} & \mathbf{W}_n^{0.5}] \underline{w}(t) = \underline{n}(t) \end{cases} \quad (6.204)$$

And:

$$\begin{aligned} \underline{z}^T(t) \underline{z}(t) &= (\mathbf{C}_1 \underline{x}(t) + \mathbf{D}_{12} \underline{w}(t))^T (\mathbf{C}_1 \underline{x}(t) + \mathbf{D}_{12} \underline{w}(t)) \\ &= \underline{x}^T(t) \mathbf{Q} \underline{x}(t) + \underline{u}^T(t) \mathbf{R} \underline{u}(t) \end{aligned} \quad (6.205)$$

Thus costs (6.197) and (6.201) are equivalent.

6.11 Sensor data fusion

6.11.1 Complementary filter

Sensor data fusion considers the problem to integrate redundant measurement information from separate sensor systems.

The basic idea of complementary filter consists in taking the measurements of two sensors, filtering out low-frequency and high-frequency noises of each sensor, and combining the filtered outputs to get a better estimate of the signal

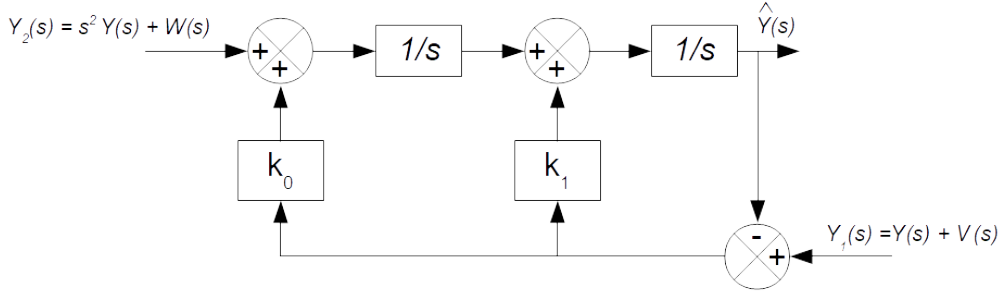

Figure 6.10: Complementary filter implementing fusion between baro-altimeter and vertical accelerometer measurements

of interest. An example of two sensors that complement each other are baro-altimeter and vertical accelerometer.

Let $y_1(t)$ and $y_2(t)$ noisy measurements of some signal $y(t)$, coming for example from a baro-altimeter and a vertical accelerometer, respectively. Denoting by $v(t)$ some low frequency zero mean noise process, by $w(t)$ some high frequency zero mean noise process and by s the Laplace variable, we will assume that:

$$\begin{cases} y_1(t) = y(t) + v(t) \\ y_2(t) = \ddot{y}(t) + w(t) \end{cases} \Leftrightarrow \begin{cases} Y_1(s) = Y(s) + V(s) \\ Y_2(s) = s^2 Y(s) + W(s) \end{cases} \quad (6.206)$$

The complementary filter that implements the fusion between the two measurements is shown in Figure 6.10⁶.

From Figure 6.10, the expression of $\hat{Y}(s)$ reads:

$$\begin{aligned} \hat{Y}(s) &= \frac{1}{s} \left(k_1 \left(Y_1(s) - \hat{Y}(s) \right) \right. \\ &\quad \left. + \frac{1}{s} \left(Y_2(s) + k_0 \left(Y_1(s) - \hat{Y}(s) \right) \right) \right) \\ \Leftrightarrow \left(1 + \frac{k_1}{s} + \frac{k_0}{s^2} \right) \hat{Y}(s) &= \left(\frac{k_1}{s} + \frac{k_0}{s^2} \right) Y_1(s) + \frac{1}{s^2} Y_2(s) \\ \Leftrightarrow \hat{Y}(s) &= \frac{k_1 s + k_0}{s^2 + k_1 s + k_0} Y_1(s) + \frac{1}{s^2 + k_1 s + k_0} Y_2(s) \end{aligned} \quad (6.207)$$

Using the fact that $Y_1(s) = Y(s) + V(s)$ and $Y_2(s) = s^2 Y(s) + W(s)$, we finally get:

$$\begin{aligned} \hat{Y}(s) &= Y(s) + \frac{k_1 s + k_0}{s^2 + k_1 s + k_0} V(s) + \frac{1}{s^2 + k_1 s + k_0} W(s) \\ &:= Y(s) + F(s) V(s) + \frac{1 - F(s)}{s^2} W(s) \end{aligned} \quad (6.208)$$

where:

$$F(s) := \frac{k_1 s + k_0}{s^2 + k_1 s + k_0} \Leftrightarrow 1 - F(s) := \frac{s^2}{s^2 + k_1 s + k_0} \quad (6.209)$$

Transfer function $F(s)$ is a low-pass filter with unity static gain whereas $1 - F(s)$ is a high-pass filter.

⁶W. T. Higgins, A Comparison of Complementary and Kalman Filtering, IEEE Transactions on Aerospace and Electronic Systems, vol. AES-11, no. 3, pp. 321-325, May 1975, doi: 10.1109/TAES.1975.308081.

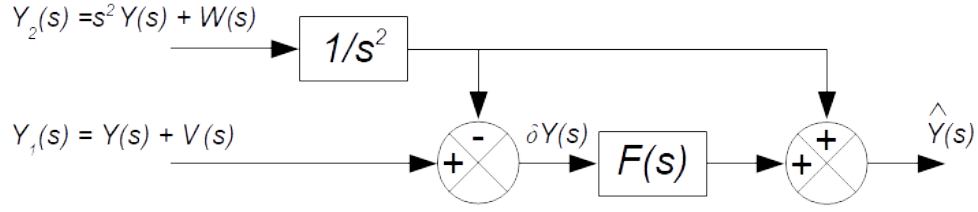

Figure 6.11: Equivalent filter implementing fusion between baro-altimeter and vertical accelerometer measurements

Thanks to the expression of $F(s)$, relation (6.207) can also be written as follows:

$$\begin{aligned}\hat{Y}(s) &= F(s) Y_1(s) + \left(\frac{1-F(s)}{s^2}\right) Y_2(s) \\ &= \frac{1}{s^2} Y_2(s) + F(s) \left(Y_1(s) - \frac{1}{s^2} Y_2(s)\right)\end{aligned}\quad (6.210)$$

Relation (6.210) leads to an equivalent version of the complementary filter shown in Figure 6.11 where the low-pass filter $F(s)$ operates only on the noises.

6.11.2 Kalman filter

More generally, there are two measurements for sensor data fusion problems, $\underline{y}_1(t)$ and $\underline{y}_2(t)$, and one of it serves as an input to the state equation, which is seen as the process model. Denoting $\underline{v}(t)$ the random process which represents the measurement noise and $\tilde{\underline{x}}(t)$ the *noisy* state vector, we have:

$$\boxed{\begin{cases} \dot{\tilde{\underline{x}}}(t) = \mathbf{A} \tilde{\underline{x}}(t) + \mathbf{B} \underline{y}_2(t) & \text{(process)} \\ \underline{y}_1(t) = \mathbf{C} \underline{x}(t) + \underline{v}(t) & \text{(measurement)} \end{cases}}\quad (6.211)$$

Take care that in the *measurement* equation, this is the *actual* state vector $\underline{x}(t)$ which is used, not the *noisy* state vector $\tilde{\underline{x}}(t)$ of the *process* equation.

Furthermore, denoting $\underline{w}(t)$ the random processes which represents the process noise, and $\underline{y}_2(t) := \underline{u}(t) + \underline{w}(t)$, we finally get:

$$\underline{y}_2(t) := \underline{u}(t) + \underline{w}(t) \Rightarrow \begin{cases} \dot{\tilde{\underline{x}}}(t) = \mathbf{A} \tilde{\underline{x}}(t) + \mathbf{B} (\underline{u}(t) + \underline{w}(t)) \\ \underline{y}_1(t) = \mathbf{C} \underline{x}(t) + \underline{v}(t) \end{cases}\quad (6.212)$$

Assuming no noise, $\underline{v}(t) = \underline{w}(t) = \underline{0}$, then $\tilde{\underline{x}}(t)$ changes into its *noiseless* value $\underline{x}(t)$ and actual measurement $\underline{y}_1(t)$ changes into its *noiseless* value $\underline{y}(t)$. Then we get the following *noiseless* state equation:

$$\underline{v}(t) = \underline{w}(t) = \underline{0} \Rightarrow \begin{cases} \dot{\underline{x}}(t) = \mathbf{A} \underline{x}(t) + \mathbf{B} \underline{u}(t) \\ \underline{y}(t) = \mathbf{C} \underline{x}(t) \end{cases}\quad (6.213)$$

The error equations reads as follows where $\delta \underline{x}(t)$ is the error state vector and $\delta \underline{y}(t)$ the error output vector. Note that we define $\delta \underline{y}(t)$ as $\delta \underline{y}(t) := \underline{y}_1(t) - \mathbf{C} \tilde{\underline{x}}(t)$ to be compliant with Figure 6.11:

$$\begin{cases} \delta \underline{x}(t) := \tilde{\underline{x}}(t) - \underline{x}(t) \\ \delta \underline{y}(t) := \underline{y}_1(t) - \mathbf{C} \tilde{\underline{x}}(t) \end{cases} \Rightarrow \begin{cases} \delta \dot{\underline{x}}(t) = \mathbf{A} \delta \underline{x}(t) + \mathbf{B} \underline{w}(t) \\ \delta \underline{y}(t) = -\mathbf{C} \delta \underline{x}(t) + \underline{v}(t) \end{cases}\quad (6.214)$$

According to (6.10), the dynamics of the observer, which is actually a Kalman-Bucy filter, reads:

$$\begin{aligned}\dot{\hat{\underline{x}}}(t) &= \mathbf{A} \delta \hat{\underline{x}}(t) + \mathbf{L}(t) (\delta \underline{y}(t) - (-\mathbf{C}) \delta \hat{\underline{x}}(t)) \\ &= \mathbf{A} \delta \hat{\underline{x}}(t) + \mathbf{L}(t) (\delta \underline{y}(t) + \mathbf{C} \delta \hat{\underline{x}}(t))\end{aligned}\quad (6.215)$$

The time dependent observer gain $\mathbf{L}(t)$, also-called Kalman gain, is similar to (6.71):

$$\mathbf{L}(t) = \mathbf{Y}(t) (-\mathbf{C})^T \mathbf{P}_v^{-1} = -\mathbf{Y}(t) \mathbf{C}^T \mathbf{P}_v^{-1} \quad (6.216)$$

where matrix $\mathbf{Y}(t)$ is the solution of the following *differential* Riccati equation (see (6.72) where \mathbf{P}_w has been replaced by $\mathbf{B} \mathbf{P}_w \mathbf{B}^T$, that is the covariance of noise $\mathbf{B} \underline{w}(t)$):

$$\dot{\mathbf{Y}}(t) = \mathbf{A} \mathbf{Y}(t) + \mathbf{Y}(t) \mathbf{A}^T - \mathbf{Y}(t) \mathbf{C}^T \mathbf{P}_v^{-1} \mathbf{C} \mathbf{Y}(t) + \mathbf{B} \mathbf{P}_w \mathbf{B}^T \quad (6.217)$$

The steady-state Kalman filter is achieved when $\dot{\mathbf{Y}}(t) = \mathbf{0}$. Then the preceding *differential* Riccati equation turns to be the *algebraic* Riccati equation and matrix \mathbf{Y} is the *constant* positive solution of the following *algebraic* Riccati equation:

$$\mathbf{0} = \mathbf{A} \mathbf{Y} + \mathbf{Y} \mathbf{A}^T - \mathbf{Y} \mathbf{C}^T \mathbf{P}_v^{-1} \mathbf{C} \mathbf{Y} + \mathbf{B} \mathbf{P}_w \mathbf{B}^T \quad (6.218)$$

Furthermore the actual estimate of the signal reads:

$$\delta \hat{\underline{x}}(t) = \tilde{\underline{x}}(t) - \hat{\underline{x}}(t) \Leftrightarrow \hat{\underline{x}}(t) = \tilde{\underline{x}}(t) - \delta \hat{\underline{x}}(t) \quad (6.219)$$

By taking the time derivative of the preceding equation, and using (6.211) and (6.214), we get the state equation for the estimate of the actual state vector $\hat{\underline{x}}(t)$:

$$\begin{aligned}\dot{\hat{\underline{x}}}(t) &= \dot{\tilde{\underline{x}}}(t) - \dot{\delta \hat{\underline{x}}}(t) \\ &= \mathbf{A} \tilde{\underline{x}}(t) + \mathbf{B} \underline{y}_2(t) - (\mathbf{A} \delta \hat{\underline{x}}(t) + \mathbf{L}(t) (\delta \underline{y}(t) + \mathbf{C} \delta \hat{\underline{x}}(t))) \\ &= \mathbf{A} (\tilde{\underline{x}}(t) - \delta \hat{\underline{x}}(t)) + \mathbf{B} \underline{y}_2(t) \\ &\quad + \mathbf{L}(t) (\underline{y}_1(t) - \mathbf{C} \tilde{\underline{x}}(t) + \mathbf{C} (\tilde{\underline{x}}(t) - \hat{\underline{x}}(t)))\end{aligned}\quad (6.220)$$

We finally get:

$$\boxed{\dot{\hat{\underline{x}}}(t) = \mathbf{A} \hat{\underline{x}}(t) + \mathbf{B} \underline{y}_2(t) + \mathbf{L}(t) (\underline{y}_1(t) - \mathbf{C} \hat{\underline{x}}(t))} \quad (6.221)$$

6.11.3 Relation between complementary filter and Kalman filter

By taking the Laplace transform of (6.221), and assuming that $\mathbf{L}(t)$ is constant, we get:

$$\begin{aligned}\mathbf{L}(t) := \mathbf{L} \Rightarrow s \hat{\underline{X}}(s) &= \mathbf{A} \hat{\underline{X}}(s) + \mathbf{B} \underline{Y}_2(s) + \mathbf{L} (\underline{Y}_1(s) - \mathbf{C} \hat{\underline{X}}(s)) \\ \Rightarrow \hat{\underline{X}}(s) &= (s\mathbb{I} - (\mathbf{A} - \mathbf{L}\mathbf{C}))^{-1} (\mathbf{L} \underline{Y}_1(s) + \mathbf{B} \underline{Y}_2(s))\end{aligned}\quad (6.222)$$

Then let $\hat{y}(t) = \mathbf{C}\hat{x}(t)$. Multiplying (6.222) by \mathbf{C} yields:

$$\mathbf{C}\hat{X}(s) = \hat{Y}(s) = \mathbf{C} (s\mathbb{I} - (\mathbf{A} - \mathbf{LC}))^{-1} (\mathbf{L}\underline{Y}_1(s) + \mathbf{B}\underline{Y}_2(s)) \quad (6.223)$$

Comparing the preceding relation with (6.210), we conclude that complementary filter and Kalman filter are equivalent. Furthermore the transfer function $F(s)$ of the low-pass filter reads as follows:

$$F(s) = \mathbf{C} (s\mathbb{I} - (\mathbf{A} - \mathbf{LC}))^{-1} \mathbf{L} \quad (6.224)$$

Example 6.3. In the specific case of sensor fusion between baro-altimeter and vertical accelerometer presented in (6.206), the state vector can be chosen as follows, assuming no noise:

$$\begin{cases} x_1(t) := y(t) \\ x_2(t) := \dot{y}(t) \end{cases} \quad (6.225)$$

Then (6.211) reads:

$$\begin{cases} \begin{bmatrix} \dot{\tilde{x}}_1(t) \\ \dot{\tilde{x}}_2(t) \end{bmatrix} = \begin{bmatrix} 0 & 1 \\ 0 & 0 \end{bmatrix} \begin{bmatrix} \tilde{x}_1(t) \\ \tilde{x}_2(t) \end{bmatrix} + \begin{bmatrix} 0 \\ 1 \end{bmatrix} (\dot{y}(t) + w(t)) \\ \quad \quad \quad := \mathbf{A}\tilde{\mathbf{x}}(t) + \mathbf{B}y_2(t) \\ \underline{y}_1(t) = \begin{bmatrix} 1 & 0 \end{bmatrix} \underline{\mathbf{x}}(t) + \underline{v}(t) \\ \quad \quad \quad := \mathbf{C}\underline{\mathbf{x}}(t) + \underline{v}(t) \end{cases} \quad (6.226)$$

Let \mathbf{L} be the steady state observer gain, also-called steady state Kalman gain, which is obtained as follows:

$$\mathbf{L} = -\mathbf{Y}\mathbf{C}^T\mathbf{P}_v^{-1} \quad (6.227)$$

where matrix \mathbf{Y} is the constant positive solution of the following algebraic Riccati equation:

$$\mathbf{0} = \mathbf{A}\mathbf{Y} + \mathbf{Y}\mathbf{A}^T - \mathbf{Y}\mathbf{C}^T\mathbf{P}_v^{-1}\mathbf{C}\mathbf{Y} + \mathbf{B}\mathbf{P}_w\mathbf{B}^T \quad (6.228)$$

Then, according to (6.224), the transfer function $F(s)$ of the low-pass filter reads as follows:

$$\begin{aligned} \mathbf{L} := \begin{bmatrix} k_1 \\ k_0 \end{bmatrix} &\Rightarrow F(s) = \mathbf{C} (s\mathbb{I} - (\mathbf{A} - \mathbf{LC}))^{-1} \mathbf{L} \\ &= \begin{bmatrix} 1 & 0 \end{bmatrix} \begin{bmatrix} s + k_1 & -1 \\ k_0 & s \end{bmatrix}^{-1} \begin{bmatrix} k_1 \\ k_0 \end{bmatrix} \\ &= \frac{k_1 s + k_0}{s^2 + k_1 s + k_0} \end{aligned} \quad (6.229)$$

We then retrieve the expression of $F(s)$ obtained in (6.209). ■

More generally, and following Higgins⁶, typical application of the Kalman filter in navigation systems extends Figure 6.11 as shown in Figure 6.12, although, as seen before, the actual implementation may be different. Note that the Kalman filter just operates on noises and is not affected by actual signals that are to be estimated.

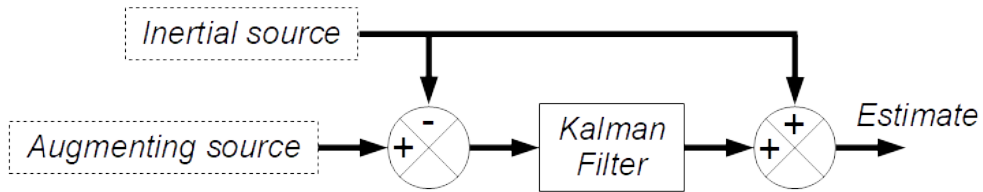

Figure 6.12: Typical application of the Kalman filter in inertial navigation

6.12 Euler angles estimation

6.12.1 One dimensional attitude estimation

System description

We consider the simple pendulum in Figure 6.13 fitted with an accelerometer and a gyroscope in the ball at the end of the arm.

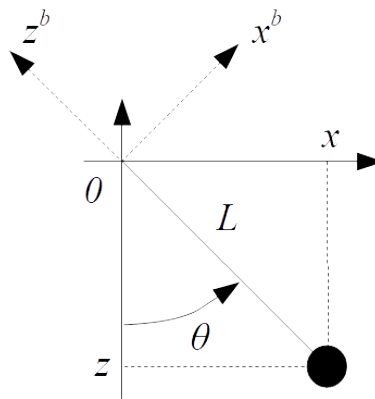

Figure 6.13: Simple pendulum

Accelerometer measurement

First, we compute the position, velocity and acceleration in the inertial frame:

– Inertial position:

$$\begin{cases} x = L \sin(\theta) \\ z = -L \cos(\theta) \end{cases} \quad (6.230)$$

– Inertial velocity:

$$\begin{cases} \dot{x} = L \dot{\theta} \cos(\theta) \\ \dot{z} = L \dot{\theta} \sin(\theta) \end{cases} \quad (6.231)$$

– Inertial acceleration:

$$\begin{cases} \ddot{x} = L \ddot{\theta} \cos(\theta) - L \dot{\theta}^2 \sin(\theta) \\ \ddot{z} = L \ddot{\theta} \sin(\theta) + L \dot{\theta}^2 \cos(\theta) \end{cases} \quad (6.232)$$

Let a_x and a_z the x -component and z -component provided by the accelerometer. Because the accelerometer is linked to the body frame, and denoting by \mathbf{R}_i^b the rotation matrix from the inertial frame to the body frame, it provides the following data, known as *specific acceleration*:

$$\begin{bmatrix} a_x \\ a_z \end{bmatrix} = \mathbf{R}_i^b \left(\begin{bmatrix} \ddot{y} \\ \ddot{z} \end{bmatrix} - \begin{bmatrix} 0 \\ -g \end{bmatrix} \right) \quad (6.233)$$

where:

$$\mathbf{R}_i^b = \begin{bmatrix} \cos(\theta) & \sin(\theta) \\ -\sin(\theta) & \cos(\theta) \end{bmatrix} \quad (6.234)$$

Thus:

$$\begin{bmatrix} a_x \\ a_z \end{bmatrix} = \begin{bmatrix} L\ddot{\theta} + g \sin(\theta) \\ L\dot{\theta}^2 + g \cos(\theta) \end{bmatrix} \quad (6.235)$$

Then neglecting $\dot{\theta}^2$ and $\ddot{\theta}$ we get:

$$\frac{a_x}{a_z} = \frac{L\ddot{\theta} + g \sin(\theta)}{L\dot{\theta}^2 + g \cos(\theta)} \approx \frac{g \sin(\theta)}{g \cos(\theta)} = \tan(\theta) \quad (6.236)$$

Thus a first approximation of angle θ , provided by the accelerometer, is θ_a where:

$$\theta_a \approx \arctan \left(\frac{a_x}{a_z} \right) \quad (6.237)$$

Attitude estimation problem

For this one dimensional example, the gyroscope provides $q := \dot{\theta}$. Then attitude estimation problem consists in computing an estimate of θ from noisy measurements of a_x , a_z and q .

6.12.2 One dimensional complementary filter

Sensor data fusion considers the problem to integrate redundant measurement information from separate sensor systems.

The basic idea of complementary filter consists in taking the measurements of two sensors, filtering out low-frequency and high-frequency noises of each sensor, and combining the filtered outputs to get a better estimate of the signal of interest. An example of two sensors that complement each other are gyro and accelerometer.

Let $y_1(t)$ and $y_2(t)$ noisy measurements of some signal $y(t)$, coming for example from an accelerometer and a gyroscope, respectively. Denoting by $v(t)$ some low frequency zero mean noise process, by $w(t)$ some high frequency zero mean noise process and by s the Laplace variable, we will assume that:

$$\begin{cases} y_1(t) = y(t) + v(t) \\ y_2(t) = \dot{y}(t) + w(t) \end{cases} \Leftrightarrow \begin{cases} Y_1(s) = Y(s) + V(s) \\ Y_2(s) = sY(s) + W(s) \end{cases} \quad (6.238)$$

For the example of section 6.12.1, we have $y_1(t) := \theta_a(t)$ and $y_2(t) := q(t)$.

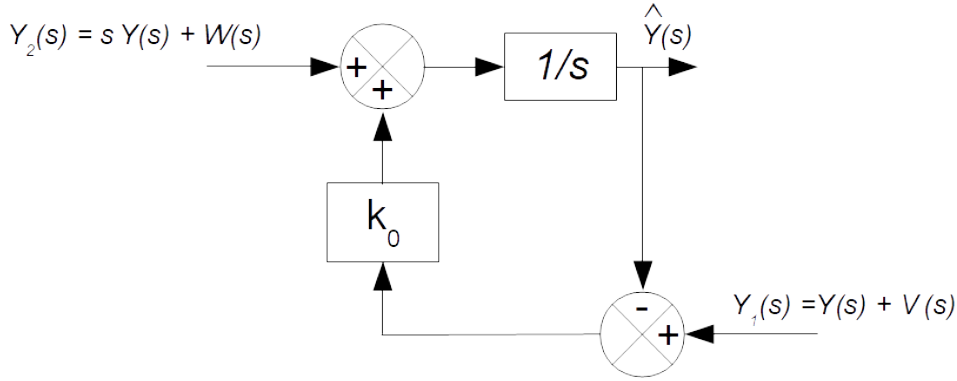

Figure 6.14: Complementary filter implementing fusion between gyro and accelerometer measurements

The complementary filter that implements the fusion between the two measurements is shown in Figure 6.14⁷.

From Figure 6.14, the expression of $\hat{Y}(s)$ reads:

$$\begin{aligned}\hat{Y}(s) &= \frac{1}{s} \left(Y_2(s) + k_0 \left(Y_1(s) - \hat{Y}(s) \right) \right) \\ \Leftrightarrow \left(1 + \frac{k_0}{s} \right) \hat{Y}(s) &= \frac{k_0}{s} Y_1(s) + \frac{1}{s} Y_2(s) \\ \Leftrightarrow \hat{Y}(s) &= \frac{k_0}{s+k_0} Y_1(s) + \frac{1}{s+k_0} Y_2(s)\end{aligned}\quad (6.239)$$

Using the fact that $Y_1(s) = Y(s) + V(s)$ and $Y_2(s) = sY(s) + W(s)$, we finally get:

$$\begin{aligned}\hat{Y}(s) &= Y(s) + \frac{k_0}{s+k_0} V(s) + \frac{1}{s+k_0} W(s) \\ &:= Y(s) + F(s) V(s) + \frac{1-F(s)}{s} W(s)\end{aligned}\quad (6.240)$$

where:

$$F(s) := \frac{k_0}{s+k_0} \Leftrightarrow 1 - F(s) := \frac{s}{s+k_0}\quad (6.241)$$

Transfer function $F(s)$ is a low-pass filter with unity static gain whereas $1 - F(s)$ is a high-pass filter.

In the continuous time domain, (6.239) reads:

$$\begin{aligned}\hat{Y}(s) &= \frac{k_0}{s+k_0} Y_1(s) + \frac{1}{s+k_0} Y_2(s) \\ \Leftrightarrow k_0 \hat{Y}(s) + s \hat{Y}(s) &= k_0 Y_1(s) + Y_2(s) \\ \Rightarrow k_0 \hat{y}(t) + \frac{d}{dt} \hat{y}(t) &= k_0 y_1(t) + y_2(t)\end{aligned}\quad (6.242)$$

In order to discretize this continuous time complementary filter, we have to find an approximation of the differentiation operator $\frac{d}{dt}$. Let T_s be the sampling period and denote z^{-1} the sample period delay operator. Several options can

⁷W. T. Higgins, A Comparison of Complementary and Kalman Filtering, IEEE Transactions on Aerospace and Electronic Systems, vol. AES-11, no. 3, pp. 321-325, May 1975, doi: 10.1109/TAES.1975.308081.

be used to approximate the differentiation operator. Using backward difference we get:

$$\frac{d}{dt} \approx \frac{1 - z^{-1}}{T_s} \quad (6.243)$$

Then (6.242) is approximated as follows at discrete-time $t = k T_s$:

$$\begin{aligned} k_0 \hat{y}(k T_s) + \dot{\hat{y}}(k T_s) &= k_0 y_1(k T_s) + y_2(k T_s) \\ \Rightarrow k_0 \hat{y}(k T_s) + \frac{\hat{y}(k T_s) - \hat{y}((k-1) T_s)}{T_s} &\approx k_0 y_1(k T_s) + y_2(k T_s) \end{aligned} \quad (6.244)$$

Usually the sampling period is omitted in the expression of the discrete-time, and the preceding relation is written as follows:

$$k_0 \hat{y}_k + \frac{\hat{y}_k - \hat{y}_{k-1}}{T_s} \approx k_0 y_{1k} + y_{2k} \quad (6.245)$$

We finally get:

$$\hat{y}_k \approx \frac{1}{1 + k_0 T_s} (\hat{y}_{k-1} + T_s (k_0 y_{1k} + y_{2k})) \quad (6.246)$$

Or equivalently:

$$\hat{y}_k \approx \alpha (\hat{y}_{k-1} + T_s y_{2k}) + (1 - \alpha) y_{1k} \text{ where } \alpha := \frac{1}{1 + k_0 T_s} \quad (6.247)$$

6.12.3 Direct Cosine Matrix (DCM) and kinematic relations

Let \underline{x}^i be a vector expressed in the inertial frame, \underline{x}^b a vector expressed in the body frame and $\mathbf{R}_i^b(\underline{\eta})$ the rotation matrix, also called Direct Cosine Matrix (DCM), from the inertial frame to the body frame:

$$\underline{x}^b = \mathbf{R}_i^b(\underline{\eta}) \underline{x}^i \quad (6.248)$$

Rotation matrix $\mathbf{R}_i^b(\underline{\eta})$ is obtained by the multiplication of the rotation matrices around Euler angles, namely yaw angle ψ , pitch angle θ and then roll angle ϕ , respectively. Denoting $c_x = \cos(x)$, $s_x = \sin(x)$ and \mathbf{R}_y the rotation matrix dedicated to angle y we get:

$$\begin{aligned} \mathbf{R}_i^b(\underline{\eta}) &= \mathbf{R}_\phi \mathbf{R}_\theta \mathbf{R}_\psi \\ &= \begin{bmatrix} 1 & 0 & 0 \\ 0 & c_\phi & s_\phi \\ 0 & -s_\phi & c_\phi \end{bmatrix} \begin{bmatrix} c_\theta & 0 & -s_\theta \\ 0 & 1 & 0 \\ s_\theta & 0 & c_\theta \end{bmatrix} \begin{bmatrix} c_\psi & s_\psi & 0 \\ -s_\psi & c_\psi & 0 \\ 0 & 0 & 1 \end{bmatrix} \\ &= \begin{bmatrix} c_\theta c_\psi & c_\theta s_\psi & -s_\theta \\ (s_\phi s_\theta c_\psi - c_\phi s_\psi) & (s_\phi s_\theta s_\psi + c_\phi c_\psi) & s_\phi c_\theta \\ (c_\phi s_\theta c_\psi + s_\phi s_\psi) & (c_\phi s_\theta s_\psi - s_\phi c_\psi) & c_\phi c_\theta \end{bmatrix} \end{aligned} \quad (6.249)$$

It is worth noticing that $\mathbf{R}_i^b(\underline{\eta})$ is an orthogonal matrix. Consequently the rotation matrix $\mathbf{R}_b^i(\underline{\eta})$ from the body frame to the inertial frame is obtained as follows:

$$\begin{aligned} \mathbf{R}_b^i(\underline{\eta}) &:= (\mathbf{R}_i^b(\underline{\eta}))^{-1} = (\mathbf{R}_i^b(\underline{\eta}))^T \\ &= \begin{bmatrix} c_\theta c_\psi & (s_\phi s_\theta c_\psi - c_\phi s_\psi) & (c_\phi s_\theta c_\psi + s_\phi s_\psi) \\ c_\theta s_\psi & (s_\phi s_\theta s_\psi + c_\phi c_\psi) & (c_\phi s_\theta s_\psi - s_\phi c_\psi) \\ -s_\theta & s_\phi c_\theta & c_\phi c_\theta \end{bmatrix} \end{aligned} \quad (6.250)$$

The relation between the angular velocities (p, q, r) in the body frame and the time derivative of the Euler angles (ϕ, θ, ψ) is the following:

$$\underline{\nu} := \begin{bmatrix} p \\ q \\ r \end{bmatrix} = \begin{bmatrix} \dot{\phi} \\ 0 \\ 0 \end{bmatrix} + \mathbf{R}_\phi \begin{bmatrix} 0 \\ \dot{\theta} \\ 0 \end{bmatrix} + \mathbf{R}_\phi \mathbf{R}_\theta \begin{bmatrix} 0 \\ 0 \\ \dot{\psi} \end{bmatrix} \quad (6.251)$$

We finally get:

$$\begin{bmatrix} p \\ q \\ r \end{bmatrix} = \begin{bmatrix} 1 & 0 & -\sin(\theta) \\ 0 & \cos(\phi) & \sin(\phi) \cos \theta \\ 0 & -\sin(\phi) & \cos(\phi) \cos \theta \end{bmatrix} \begin{bmatrix} \dot{\phi} \\ \dot{\theta} \\ \dot{\psi} \end{bmatrix} \quad (6.252)$$

That is:

$$\underline{\nu} = \mathbf{W}(\underline{\eta}) \dot{\underline{\eta}} \quad (6.253)$$

where:

$$\underline{\eta} := \begin{bmatrix} \phi \\ \theta \\ \psi \end{bmatrix} \quad (6.254)$$

and:

$$\mathbf{W}(\underline{\eta}) = \begin{bmatrix} 1 & 0 & -\sin(\theta) \\ 0 & \cos(\phi) & \sin(\phi) \cos(\theta) \\ 0 & -\sin(\phi) & \cos(\phi) \cos(\theta) \end{bmatrix} \quad (6.255)$$

It is worth noticing that the preceding relation can be obtained from the following equality which simply states that the time derivative of matrix $\mathbf{R}_b^i(\underline{\eta})$ can be seen as matrix $\mathbf{\Omega}(\underline{\nu})$ of the angular velocities in the body frame expressed in the inertial frame:

$$\frac{d}{dt} \mathbf{R}_b^i(\underline{\eta}) = \mathbf{R}_b^i(\underline{\eta}) \mathbf{\Omega}(\underline{\nu}) \quad \text{where} \quad \mathbf{\Omega}(\underline{\nu}) = -\mathbf{\Omega}(\underline{\nu})^T = \begin{bmatrix} 0 & -r & q \\ r & 0 & -p \\ -q & p & 0 \end{bmatrix} \quad (6.256)$$

Conversely we have:

$$\dot{\underline{\eta}} = \mathbf{W}(\underline{\eta})^{-1} \underline{\nu} \quad (6.257)$$

where:

$$\mathbf{W}(\underline{\eta})^{-1} = \begin{bmatrix} 1 & \sin(\phi) \tan(\theta) & \cos(\phi) \tan(\theta) \\ 0 & \cos(\phi) & -\sin(\phi) \\ 0 & \frac{\sin(\phi)}{\cos(\theta)} & \frac{\cos(\phi)}{\cos(\theta)} \end{bmatrix} \quad (6.258)$$

6.12.4 Roll and pitch angles estimation from accelerometer measurements

Let \underline{g} be the gravitational acceleration, \underline{a}^i the acceleration in the inertial frame, \underline{a}^b the acceleration in the body frame and \mathbf{R}_i^b the rotation matrix from the inertial frame to the body frame. The accelerometer provides the following measurement, called the specific acceleration:

$$\underline{a}_m = \mathbf{R}_i^b (\underline{a}^i - \underline{g}) \quad (6.259)$$

Denoting \underline{v}^i the velocity in the inertial frame and \underline{v}^b the velocity in the body frame, we have the following relation where \mathbf{R}_b^i the rotation matrix from the body frame to the inertial frame:

$$\underline{v}^i = \mathbf{R}_b^i \underline{v}^b \quad (6.260)$$

Thus, after derivation:

$$\underline{a}^i := \frac{d}{dt} \underline{v}^i = \mathbf{R}_b^i \dot{\underline{v}}^b + \dot{\mathbf{R}}_b^i \underline{v}^b \quad (6.261)$$

Thus the specific acceleration \underline{a}_m in (6.259) reads:

$$\begin{aligned} \underline{a}_m &= \mathbf{R}_i^b \left(\mathbf{R}_b^i \dot{\underline{v}}^b + \dot{\mathbf{R}}_b^i \underline{v}^b \right) - \mathbf{R}_i^b \underline{g} \\ &= \dot{\underline{v}}^b + \mathbf{R}_i^b \dot{\mathbf{R}}_b^i \underline{v}^b - \mathbf{R}_i^b \underline{g} \end{aligned} \quad (6.262)$$

Once the computation achieved, we get the following expression for the measurements provided by a 3-axis accelerometer⁸:

$$\underline{a}_m = \begin{bmatrix} a_x \\ a_y \\ a_z \end{bmatrix} = \begin{bmatrix} \dot{u} \\ \dot{v} \\ \dot{w} \end{bmatrix} + \begin{bmatrix} 0 & w & -v \\ -w & 0 & u \\ v & -u & 0 \end{bmatrix} \begin{bmatrix} p \\ q \\ r \end{bmatrix} - g \begin{bmatrix} -\sin(\theta) \\ \cos(\theta) \sin(\phi) \\ \cos(\theta) \cos(\phi) \end{bmatrix} \quad (6.263)$$

The last term of equation (6.263) can be used to approximate roll angle ϕ and pitch angle θ as follows:

$$\boxed{\begin{cases} \phi \approx \arctan\left(\frac{a_y}{a_z}\right) \\ \theta \approx \arctan\left(\frac{a_x}{\sqrt{a_y^2 + a_z^2}}\right) \end{cases}} \quad (6.264)$$

Note that if the Inertial Measurement Unit (IMU) is not situated at the center of mass, then the accelerometers coordinates (l_x, l_y, l_z) along each axis in the body frame with its origin at the center of gravity shall be taken into account and the measurements (6.263) provided by a 3-axis accelerometer becomes⁸:

$$\begin{aligned} \underline{a}_m = \begin{bmatrix} a_x \\ a_y \\ a_z \end{bmatrix} &= \begin{bmatrix} \dot{u} \\ \dot{v} \\ \dot{w} \end{bmatrix} + \begin{bmatrix} 0 & w & -v \\ -w & 0 & u \\ v & -u & 0 \end{bmatrix} \begin{bmatrix} p \\ q \\ r \end{bmatrix} - g \begin{bmatrix} -\sin(\theta) \\ \cos(\theta) \sin(\phi) \\ \cos(\theta) \cos(\phi) \end{bmatrix} \\ &+ \begin{bmatrix} -r^2 - q^2 & pq - r^2 & pr + \dot{q} \\ pq + \dot{r} & -p^2 - r^2 & rq - \dot{p} \\ pr - \dot{q} & rq + \dot{p} & -q^2 - p^2 \end{bmatrix} \begin{bmatrix} l_x \\ l_y \\ l_z \end{bmatrix} \end{aligned} \quad (6.265)$$

⁸ Marian J. Blachuta and Rafal T. Grygiel and Roman Czyba and Grzegorz Szafranski, Attitude and heading reference system based on 3D complementary filter, 2014 19th International Conference on Methods and Models in Automation and Robotics (MMAR)

6.12.5 Yaw angle estimation from magnetometer measurements

Let $[m_x^i \ 0 \ m_z^i]^T$ be the geomagnetic field measurements in the inertial frame and $[m_x \ m_y \ m_z]^T$ be the geomagnetic field measurements in the body frame. Those those vectors are related as follows:

$$\begin{aligned} \begin{bmatrix} m_x \\ m_y \\ m_z \end{bmatrix} &= \mathbf{R}_i^b \begin{bmatrix} m_x^i \\ 0 \\ m_z^i \end{bmatrix} \\ &= \begin{bmatrix} m_x^i \cos(\psi) \cos(\theta) - m_z^i \sin(\theta) \\ m_z^i \cos(\theta) \sin(\phi) - m_x^i (\cos(\phi) \sin(\psi) - \cos(\psi) \sin(\phi) \sin(\theta)) \\ m_x^i (\sin(\phi) \sin(\psi) + \cos(\phi) \cos(\psi) \sin(\theta)) + m_z^i \cos(\phi) \cos(\theta) \end{bmatrix} \end{aligned} \quad (6.266)$$

Then it is worth noticing that the following relations hold:

$$\begin{cases} \sin(\phi) m_z - \cos(\phi) m_y = m_x^i \sin(\psi) \\ \cos(\theta) m_x + \sin(\phi) \sin(\theta) m_y + \cos(\phi) \sin(\theta) m_z = m_x^i \cos(\psi) \end{cases} \quad (6.267)$$

Those two equations can be used to approximate yaw angle ψ as follows:

$$\psi = \arctan\left(\frac{\sin(\phi) m_z - \cos(\phi) m_y}{\cos(\theta) m_x + \sin(\phi) \sin(\theta) m_y + \cos(\phi) \sin(\theta) m_z}\right) \quad (6.268)$$

6.12.6 Angular velocity from gyroscope measurements

Gyroscope provides the roll, pitch and yaw rate, p , q and r , respectively, with respect to its body axis system. The relationship between rate gyro output and angular velocity of the Euler angles is similar to (6.258). Nevertheless, because the actual values of the Euler angles ϕ , θ and ψ is not known, it is their estimated values $\hat{\phi}$, $\hat{\theta}$ and $\hat{\psi}$ which is used in matrix $\mathbf{W}(\hat{\eta})$:

$$\frac{d}{dt} \begin{bmatrix} \phi \\ \theta \\ \psi \end{bmatrix} \approx \mathbf{W}(\hat{\eta})^{-1} \underline{v} = \begin{bmatrix} 1 & \sin(\hat{\phi}) \tan(\hat{\theta}) & \cos(\hat{\phi}) \tan(\hat{\theta}) \\ 0 & \cos(\hat{\phi}) & -\sin(\hat{\phi}) \\ 0 & \frac{\sin(\hat{\phi})}{\cos(\hat{\theta})} & \frac{\cos(\hat{\phi})}{\cos(\hat{\theta})} \end{bmatrix} \begin{bmatrix} p \\ q \\ r \end{bmatrix} \quad (6.269)$$

6.12.7 Attitude and Heading Reference System (AHRS) based on complementary filter

The purpose of the Attitude and Heading Reference System (AHRS) is to compute the best estimate of the Euler angles ϕ , θ and ψ from the roll and pitch estimates (6.264) provided by the accelerometers, from the yaw estimate (6.268) provided by the magnetometer and from the angular velocities (6.269) provided by the gyroscopes.

Because each channel is decoupled, the best estimate can be achieved by 3 independent complementary filters of the form (6.241) for continuous time

estimate, or (6.247) for discrete time estimate. In those equations, y_1 stands for the measurements provided by the accelerometers or the magnetometer, and y_2 stands for the measurements provided by the gyroscopes.