



HAL
open science

Introduction to Optimal Control

Thierry Miquel

► **To cite this version:**

Thierry Miquel. Introduction to Optimal Control. Master. Introduction to optimal control, ENAC, France. 2020, pp.188. hal-02987731v1

HAL Id: hal-02987731

<https://cel.hal.science/hal-02987731v1>

Submitted on 4 Nov 2020 (v1), last revised 17 Oct 2022 (v2)

HAL is a multi-disciplinary open access archive for the deposit and dissemination of scientific research documents, whether they are published or not. The documents may come from teaching and research institutions in France or abroad, or from public or private research centers.

L'archive ouverte pluridisciplinaire **HAL**, est destinée au dépôt et à la diffusion de documents scientifiques de niveau recherche, publiés ou non, émanant des établissements d'enseignement et de recherche français ou étrangers, des laboratoires publics ou privés.



Distributed under a Creative Commons Attribution - NonCommercial 4.0 International License

Introduction to Optimal Control

Lecture notes - Draft

Thierry Miquel
`thierry.miquel@enac.fr`

September 25, 2020

Introduction

The application of optimal control theory to the practical design of multivariable control systems started in the 1960s: in 1957 R. Bellman applied dynamic programming to the optimal control of discrete-time systems. His procedure resulted in closed-loop, generally nonlinear, feedback schemes. By 1958, L.S. Pontryagin had developed his maximum principle, which solved optimal control problems relying on the calculus of variations developed by L. Euler (1707-1783). He solved the minimum-time problem, deriving an on/off relay control law as the optimal control in 1962. In 1960 three major papers were published by R. Kalman and coworkers, working in the U.S. One of these publicized the vital work of Lyapunov (1857-1918) in the time-domain control of nonlinear systems. The next discussed the optimal control of systems, providing the design equations for the linear quadratic regulator (LQR). The third paper discussed optimal filtering and estimation theory, which is out of the scope of this survey, and has provided the design equations for the discrete Kalman filter. The continuous Kalman filter was developed by Kalman and Bucy in 1961.

In control theory, Kalman introduced linear algebra and matrices, so that systems with multiple inputs and outputs could easily be treated. He also formalized the notion of optimality in control theory by minimizing a very general quadratic generalized energy function. In the period of a year, the major limitations of classical control theory were overcome, important new theoretical tools were introduced, and a new era in control theory had begun; we call it the era of modern control. In the period since 1980 the theory has been further refined under the name of H_2 theory in the wake of the attention for the so-called H_1 control theory. H_1 and H_2 control theory are out of the scope of this survey.

This lecture focuses on LQ (linear quadratic) theory and is a compilation of a number of results dealing with LQ (linear quadratic) theory in the context of control system design. This has been written thanks to the references put in bibliographical section. It starts with a reminder of the main results in optimization of non linear systems which will be used as a background for this lecture. Then linear quadratic regulator (LQR) for finite final time and for infinite final time where the solution to the LQ problem are discussed. The robustness properties of the linear quadratic regulator (LQR) are then presented where the asymptotic properties and the guaranteed gain and phase margins associated with the LQ solution are presented. The next section presents some design methods with a special emphasis on symmetric root locus. We conclude with a short section dedicated to the Linear Quadratic Tracker (LQT) where the usefulness of augmenting the plant with integrators is presented.

Bibliography

- [1] *Alazard D., Apkarian P. and Cumer C., Robustesse et commande optimale*, Cépaduès (2000)
- [2] *Anderson B. and Moore J., Optimal Control: Linear Quadratic Methods*, Prentice Hall (1990)
- [3] *Hespanha J. P., Linear Systems Theory*, Princeton University Press (2009)
- [4] *Hull D. G., Optimal Control Theory for Applications*, Springer (2003)
- [5] *Jeffrey B. Burl, Linear Optimal Control*, Prentice Hall (1998)
- [6] *Lewis F., Vrabie D. and Syrmos L., Optimal Control*, John Wiley & Sons (2012)
- [7] *Perry Y. Li, Linear Quadratic Optimal Control*, University of Minnesota (2012)
- [8] *Sinha A., Linear Systems: Optimal and Robust Control*, CRC Press (2007)

Table of contents

1	Overview of Pontryagin's Minimum Principle	7
1.1	Introduction	7
1.2	Variation	7
1.3	Example	9
1.4	Lagrange multipliers	10
1.5	Example	11
1.6	Euler-Lagrange equation	12
1.7	Fundamentals of optimal control theory	15
1.7.1	Problem to be solved	15
1.7.2	Bolza, Mayer and Lagrange problems	15
1.7.3	First order necessary conditions	16
1.7.4	Hamilton-Jacobi-Bellman (HJB) partial differential equation	18
1.8	Unconstrained control	19
1.9	Constrained control - Pontryagin's principle	20
1.10	Examples: bang-bang control	22
1.10.1	Example 1	22
1.10.2	Example 2	24
1.11	Free final time	26
1.12	Singular arc - Legendre-Clebsch condition	27
2	Finite Horizon Linear Quadratic Regulator	29
2.1	Problem to be solved	29
2.2	Positive definite and positive semi-definite matrix	30
2.3	Open loop solution	31
2.4	Application to minimum energy control problem	33
2.4.1	Moving a linear system close to a final state with minimum energy	33
2.4.2	Moving a linear system exactly to a final state with minimum energy	35
2.4.3	Example	36
2.5	Closed loop solution	38
2.5.1	Final state close to zero	38
2.5.2	Riccati differential equation	40
2.5.3	Final state set to zero	41
2.5.4	Using Hamilton-Jacobi-Bellman (HJB) equation	42

2.6	Solving the Riccati differential equation	44
2.6.1	Scalar Riccati differential equation	44
2.6.2	Matrix fraction decomposition	44
2.6.3	Examples	46
2.7	Second order necessary condition for optimality	49
2.8	Finite horizon LQ regulator with cross term in the performance index	49
2.9	Minimum cost achieved	52
2.10	Extension to nonlinear system affine in control	52
3	Infinite Horizon Linear Quadratic Regulator (LQR)	54
3.1	Problem to be solved	54
3.2	Stabilizability and detectability	54
3.3	Algebraic Riccati equation	55
3.4	Extension to nonlinear system affine in control	57
3.5	Solution of the algebraic Riccati equation	59
3.5.1	Hamiltonian matrix based solution	59
3.5.2	Proof of the results on the the Hamiltonian matrix	59
3.5.3	Solving general algebraic Riccati and Lyapunov equations	61
3.6	Eigenvalues of full-state feedback control	62
3.7	Generalized (MIMO) Nyquist stability criterion	64
3.8	Kalman equality	66
3.9	Robustness of Linear Quadratic Regulator	66
3.10	Discrete time LQ regulator	69
3.10.1	Finite horizon LQ regulator	69
3.10.2	Finite horizon LQ regulator with zero terminal state	69
3.10.3	Infinite horizon LQ regulator	71
4	Design methods	73
4.1	Characteristics polynomials	73
4.2	Root Locus technique reminder	74
4.3	Symmetric Root Locus	75
4.3.1	Chang-Letov design procedure	75
4.3.2	Proof of the symmetric root locus result	77
4.4	Asymptotic properties	78
4.4.1	Closed loop poles location	78
4.4.2	Shape of the magnitude of the open-loop gain $\mathbf{K}\Phi(s)\mathbf{B}$	80
4.4.3	Weighting matrices selection	81
4.5	Poles shifting in optimal regulator	82
4.5.1	Mirror property	82
4.5.2	Reduced-order model	84
4.5.3	Shifting one real eigenvalue	84
4.5.4	Shifting a pair of complex conjugate eigenvalues	85
4.5.5	Sequential pole shifting via reduced-order models	86
4.6	Frequency domain approach	87
4.6.1	Non optimal pole assignment	87
4.6.2	Solving the algebraic Riccati equation	88

4.6.3	Poles assignment in optimal regulator using root locus . . .	89
4.7	Poles assignment in optimal regulator through matrix inequalities	91
4.8	Model matching	92
4.8.1	Cross term in the performance index	92
4.8.2	Implicit reference model	93
4.9	Frequency shaped LQ control	95
4.10	Optimal transient stabilization	97
5	Linear Quadratic Tracker (LQT)	100
5.1	Introduction	100
5.2	Optimal LQ tracker	100
5.2.1	Finite horizon Linear Quadratic Tracker	100
5.2.2	Infinite horizon Linear Quadratic Tracker	103
5.3	Control with feedforward gain	103
5.4	Plant augmented with integrator	104
5.4.1	Integral augmentation	104
5.4.2	Proof of the cancellation of the steady state error through integral augmentation	106
5.5	Dynamic compensator	108
6	Linear Quadratic Gaussian (LQG) regulator	110
6.1	Introduction	110
6.2	Luenberger observer	111
6.3	White noise through Linear Time Invariant (LTI) system	112
6.3.1	Assumptions and definitions	112
6.3.2	Mean and covariance matrix of the state vector	112
6.3.3	Autocorrelation function of the stationary output vector	113
6.4	Kalman-Bucy filter	116
6.4.1	Linear Quadratic Estimator	116
6.4.2	Sketch of the proof	117
6.5	Duality principle	119
6.6	Controller transfer function	120
6.7	Separation principle	121
6.8	Loop Transfer Recovery	123
6.8.1	Lack of guaranteed robustness of LQG design	123
6.8.2	Doyle's seminal example	123
6.8.3	Loop Transfer Recovery (LTR) design	125
6.9	Proof of the Loop Transfer Recovery condition	127
6.9.1	Loop transfer function with observer	127
6.9.2	Application of matrix inversion lemma to LTR	130
6.9.3	Setting the Loop Transfer Recovery design parameter	131
6.10	H_2 robust control design	132

Chapter 1

Overview of Pontryagin's Minimum Principle

1.1 Introduction

Pontryagin's Minimum (or Maximum) Principle was formulated in 1956 by the Russian mathematician Lev Pontryagin (1908 - 1988) and his students¹. Its initial application was to the maximization of the terminal speed of a rocket. The result was derived using ideas from the classical calculus of variations.

This chapter is devoted to the main results of optimal control theory which leads to conditions for optimality.

1.2 Variation

Optimization can be accomplished by using a generalization of the differential called variation.

Let's consider the real scalar cost function $J(\underline{x})$ of a vector $\underline{x} \in \mathbb{R}^n$. Cost function $J(\underline{x})$ has a local minimum at \underline{x}^* if and only if for all $\delta\underline{x}$ sufficiently small;

$$J(\underline{x}^* + \delta\underline{x}) \geq J(\underline{x}^*) \quad (1.1)$$

An equivalent statement is that:

$$\Delta J(\underline{x}^*, \delta\underline{x}) = J(\underline{x}^* + \delta\underline{x}) - J(\underline{x}^*) \geq 0 \quad (1.2)$$

The term $\Delta J(\underline{x}^*, \delta\underline{x})$ is called the increment of $J(\underline{x})$. The optimality condition can be found by expanding $J(\underline{x}^* + \delta\underline{x})$ in a Taylor series around the extremum point \underline{x}^* . When $J(\underline{x})$ is a scalar function of multiple variables, the expansion of $J(\underline{x})$ in the Taylor series involves the gradient and the Hessian of the cost function $J(\underline{x})$:

- Assuming that $J(\underline{x})$ is a differentiable function, the term $\frac{dJ(\underline{x}^*)}{d\underline{x}}$ is the gradient of $J(\underline{x})$ at $\underline{x}^* \in \mathbb{R}^n$ which is the vector of \mathbb{R}^n defined by:

¹https://en.wikipedia.org/wiki/Pontryagin's_maximum_principle

$$\frac{dJ(\underline{x}^*)}{d\underline{x}} = \nabla J(\underline{x}^*) = \left[\begin{array}{c} \frac{dJ(\underline{x})}{dx_1} \\ \vdots \\ \frac{dJ(\underline{x})}{dx_n} \end{array} \right]_{\underline{x}=\underline{x}^*} \quad (1.3)$$

- Assuming that $J(\underline{x})$ is a twice differentiable function, the term $\frac{d^2 J(\underline{x}^*)}{d\underline{x}^2}$ is the Hessian of $J(\underline{x})$ at $\underline{x}^* \in \mathbb{R}^n$ which is the symmetric $n \times n$ matrix defined by:

$$\frac{d^2 J(\underline{x}^*)}{d\underline{x}^2} = \nabla^2 J(\underline{x}^*) = \left[\begin{array}{ccc} \frac{\partial^2 J(\underline{x})}{\partial x_1 \partial x_1} & \cdots & \frac{\partial^2 J(\underline{x})}{\partial x_1 \partial x_n} \\ \vdots & & \vdots \\ \frac{\partial^2 J(\underline{x})}{\partial x_n \partial x_1} & \cdots & \frac{\partial^2 J(\underline{x})}{\partial x_n \partial x_n} \end{array} \right]_{\underline{x}=\underline{x}^*} = \left[\frac{d^2 J(\underline{x}^*)}{dx_i dx_j} \right]_{1 \leq i, j \leq n} \quad (1.4)$$

Expanding $J(\underline{x}^* + \delta\underline{x})$ in a Taylor series around the point \underline{x}^* leads to the following expression, where *HOT* stands for *Higher-Order Terms*:

$$J(\underline{x}^* + \delta\underline{x}) = J(\underline{x}^*) + \delta\underline{x}^T \nabla J(\underline{x}^*) + \frac{1}{2} \delta\underline{x}^T \nabla^2 J(\underline{x}^*) \delta\underline{x} + HOT \quad (1.5)$$

Thus:

$$\begin{aligned} \Delta J(\underline{x}^*, \delta\underline{x}) &= J(\underline{x}^* + \delta\underline{x}) - J(\underline{x}^*) \\ &= \delta\underline{x}^T \nabla J(\underline{x}^*) + \frac{1}{2} \delta\underline{x}^T \nabla^2 J(\underline{x}^*) \delta\underline{x} + HOT \end{aligned} \quad (1.6)$$

When dealing with a functional (a real scalar function of functions) $\delta\underline{x}$ is called the variation of \underline{x} and the term in the increment $\Delta J(\underline{x}^*, \delta\underline{x})$ which is linear in $\delta\underline{x}^T$ is called the variation of J and is denoted $\delta J(\underline{x}^*)$. The variation of $J(\underline{x})$ is a generalization of the differential and can be applied to the optimization of a functional. Equation (1.6) can be used to develop necessary conditions for optimality. Indeed as $\delta\underline{x}$ approaches zero the terms $\delta\underline{x}^T \delta\underline{x}$ as well as *HOT* become arbitrarily small compared to $\delta\underline{x}$. As a consequence, *a necessary condition for \underline{x}^* to be a local extremum of the cost function J is that the first variation of J (its gradient) at \underline{x}^* is zero:*

$$\delta J(\underline{x}^*) = \nabla J(\underline{x}^*) = 0 \quad (1.7)$$

A critical (or stationary) point \underline{x}^* is a point where $\delta J(\underline{x}^*) = \nabla J(\underline{x}^*) = 0$. Furthermore the sign of the Hessian provides sufficient condition for a local extremum. Let's write the Hessian $\nabla^2 J(\underline{x}^*)$ at the critical point \underline{x}^* as follows:

$$\nabla^2 J(\underline{x}^*) = \left[\begin{array}{ccc} h_{11} & \cdots & h_{1n} \\ \vdots & & \vdots \\ h_{n1} & \cdots & h_{nn} \end{array} \right] \quad (1.8)$$

- The sufficient condition for the critical point \underline{x}^* to be a local minimum is that the Hessian is positive definite, that is that all the principal minor determinants are positive:

$$\Leftrightarrow \begin{cases} \forall 1 \leq k \leq n H_k > 0 \\ H_1 = h_{11} > 0 \\ H_2 = \begin{vmatrix} h_{11} & h_{12} \\ h_{21} & h_{22} \end{vmatrix} > 0 \\ H_3 = \begin{vmatrix} h_{11} & h_{12} & h_{13} \\ h_{21} & h_{22} & h_{23} \\ h_{31} & h_{32} & h_{33} \end{vmatrix} > 0 \\ \text{and so on...} \end{cases} \quad (1.9)$$

- The sufficient condition for the critical point \underline{x}^* to be a local maximum is that the Hessian is negative definite, or equivalently that the opposite of the Hessian is positive definite:

$$\Leftrightarrow \begin{cases} \forall 1 \leq k \leq n (-1)^k H_k > 0 \\ H_1 = h_{11} < 0 \\ H_2 = \begin{vmatrix} h_{11} & h_{12} \\ h_{21} & h_{22} \end{vmatrix} > 0 \\ H_3 = \begin{vmatrix} h_{11} & h_{12} & h_{13} \\ h_{21} & h_{22} & h_{23} \\ h_{31} & h_{32} & h_{33} \end{vmatrix} < 0 \\ \text{and so on...} \end{cases} \quad (1.10)$$

- If the Hessian has both positive and negative eigenvalues then the critical point \underline{x}^* is a saddle point for the cost function $J(\underline{x})$.

It should be emphasized that if the Hessian is positive semi-definite or negative semi-definite or has null eigenvalues at a critical point \underline{x}^* , then it cannot be concluded that the critical point is a minimizer or a maximizer or a saddle point of the cost function $J(\underline{x})$ and the test is inconclusive.

1.3 Example

Find the local maxima/minima for the following cost function:

$$J(\underline{x}) = 5 - (x_1 - 2)^2 - 2(x_2 - 1)^2 \quad (1.11)$$

First let's compute the first variation of J , or equivalently its gradient:

$$\frac{dJ(\underline{x})}{d\underline{x}} = \nabla J(\underline{x}) = \begin{bmatrix} \frac{dJ(\underline{x})}{dx_1} \\ \frac{dJ(\underline{x})}{dx_2} \end{bmatrix} = \begin{bmatrix} -2(x_1 - 2) \\ -4(x_2 - 1) \end{bmatrix} \quad (1.12)$$

A necessary condition for \underline{x}^* to be a local extremum is that the first variation of J at \underline{x}^* is zero for all $\delta\underline{x}$:

$$\delta J(\underline{x}^*) = \nabla J(\underline{x}^*) = 0 \quad (1.13)$$

As a consequence, the following point is a critical point:

$$\underline{x}^* = \begin{bmatrix} 2 \\ 1 \end{bmatrix} \quad (1.14)$$

Now, we compute the Hessian to conclude on the nature of this critical point:

$$\nabla^2 J(\underline{x}^*) = \begin{bmatrix} -2 & 0 \\ 0 & -4 \end{bmatrix} \quad (1.15)$$

As far as the Hessian is negative definite we conclude that the critical point \underline{x}^* is a local maximum.

1.4 Lagrange multipliers

Optimal control problems which will be tackled involve minimization of a cost function subject to constraints on the state vector and the control. The necessary condition given above is only applicable to unconstrained minimization problems; Lagrange multipliers provide a method of converting a constrained minimization problem into an unconstrained minimization problem of higher order. Optimization can then be performed using the above necessary condition. A constrained optimization problem is a problem of the form:

maximize (or minimize) cost function $J(\underline{x})$ subject to the condition $g(\underline{x}) = 0$

The most popular technique to solve this constrained optimization problem is to use the Lagrange multiplier technique. Necessary condition for optimality of J at a point \underline{x}^* are that \underline{x}^* satisfies $g(\underline{x}) = 0$ and that the gradient of J is zero in all direction along the surface $g(\underline{x}) = 0$; this condition is satisfied if the gradient of J is normal to the surface at \underline{x}^* . As far as the gradient of $g(\underline{x})$ is normal to the surface, including \underline{x}^* , this condition is satisfied if the gradient of J is parallel (that is proportional) to the gradient of $g(\underline{x})$ at \underline{x}^* , or equivalently:

$$\frac{\partial J(\underline{x}^*)}{\partial \underline{x}} + \underline{\lambda}^T \frac{\partial g(\underline{x}^*)}{\partial \underline{x}} = 0 \quad (1.16)$$

As an illustration consider the cost function $J(\underline{x}) = (x_1 - 1)^2 + (x_2 - 2)^2$: this is the equation of a circle of center $(1, 2)$ with radius $J(\underline{x})$. It is clear that $J(\underline{x})$ is minimal when (x_1, x_2) is situated on the center of the circle. In this case $J(\underline{x})^* = 0$. Nevertheless if we impose on (x_1, x_2) to belong to the straight line defined by $x_2 - 2x_1 - 6 = 0$ then $J(\underline{x})$ will be minimized as soon as the circle of radius $J(\underline{x})$ tangent the straight line, that is if the gradient of $J(\underline{x})$ is normal to the surface at \underline{x}^* . Parameter $\underline{\lambda}$ is called the Lagrange multiplier and has the dimension of the number of constraints expressed through $g(\underline{x})$. The necessary condition for optimality can be obtained as the solution of the following unconstrained optimization problem where $L(\underline{x}, \underline{\lambda})$ is the Lagrange function:

$$L(\underline{x}, \underline{\lambda}) = J(\underline{x}) + \underline{\lambda}^T g(\underline{x}) \quad (1.17)$$

Setting to zero the gradient of the Lagrange function with respect to \underline{x} leads to (1.16) whereas setting to zero the derivative of the Lagrange function with respect to the Lagrange multiplier $\underline{\lambda}$ leads to the constraint $g(\underline{x}) = 0$. As a consequence, *a necessary condition for \underline{x}^* to be a local extremum of the cost function J subject to the constraint $g(\underline{x}) = 0$ is that the first variation of*

Lagrange function (its gradient) at \underline{x}^* is zero:

$$\frac{\partial L(\underline{x}^*)}{\partial \underline{x}} = 0 \Leftrightarrow \frac{\partial J(\underline{x}^*)}{\partial \underline{x}} + \underline{\lambda}^T \frac{\partial g(\underline{x}^*)}{\partial \underline{x}} = 0 \quad (1.18)$$

The bordered Hessian is the $(n + m) \times (n + m)$ symmetric matrix which is used for the second-derivative test. If there are m constraints represented by $g(\underline{x}) = 0$, then there are m border rows at the top-right and m border columns at the bottom-left (the transpose of the top-right matrix) and the zero in the south-east corner of the bordered Hessian is an $m \times m$ block of zeros, represented by $\mathbf{0}_{m \times m}$. The bordered Hessian $\mathbf{H}_b(p)$ is defined by:

$$\mathbf{H}_b(p) = \begin{bmatrix} \frac{\partial^2 L(\underline{x})}{\partial x_1 \partial x_1} - p & \frac{\partial^2 L(\underline{x})}{\partial x_1 \partial x_2} & \cdots & \frac{\partial^2 L(\underline{x})}{\partial x_1 \partial x_n} & \frac{\partial g_1(\underline{x})}{\partial x_1} & \cdots & \frac{\partial g_m(\underline{x})}{\partial x_1} \\ \frac{\partial^2 L(\underline{x})}{\partial x_2 \partial x_1} & \frac{\partial^2 L(\underline{x})}{\partial x_2 \partial x_2} - p & \cdots & \frac{\partial^2 L(\underline{x})}{\partial x_2 \partial x_n} & \frac{\partial g_1(\underline{x})}{\partial x_2} & \cdots & \frac{\partial g_m(\underline{x})}{\partial x_2} \\ \cdots & \cdots & \cdots & \cdots & \cdots & \cdots & \cdots \\ \frac{\partial^2 L(\underline{x})}{\partial x_n \partial x_1} & \frac{\partial^2 L(\underline{x})}{\partial x_n \partial x_2} & \cdots & \frac{\partial^2 L(\underline{x})}{\partial x_n \partial x_n} - p & \frac{\partial g_1(\underline{x})}{\partial x_n} & \cdots & \frac{\partial g_m(\underline{x})}{\partial x_n} \\ \frac{\partial g_1(\underline{x})}{\partial x_1} & \cdots & \cdots & \frac{\partial g_1(\underline{x})}{\partial x_n} & & & \\ \cdots & \cdots & \cdots & & & & \\ \frac{\partial g_m(\underline{x})}{\partial x_1} & \cdots & \cdots & \frac{\partial g_m(\underline{x})}{\partial x_n} & & & \end{bmatrix}_{\underline{x}=\underline{x}^*} \quad \mathbf{0}_{m \times m} \quad (1.19)$$

The sufficient condition for the critical point \underline{x}^* to be an extrema is that the values of p obtained from $\det(\mathbf{H}_b(p)) = 0$ must be of the same sign.

- If all the values of p are strictly negative, then it is a maxima
- If all the values of p are strictly positive, then it is a minima
- However if some values of p are zero or of a different sign, then the critical point \underline{x}^* is a saddle point.

1.5 Example

Find the local maxima/minima for the following cost function:

$$J(\underline{x}) = x_1 + 3x_2 \quad (1.20)$$

Subject to the constraint:

$$g(\underline{x}) = x_1^2 + x_2^2 - 10 = 0 \quad (1.21)$$

First let's compute the Lagrange function of this problem:

$$L(\underline{x}, \underline{\lambda}) = J(\underline{x}) + \underline{\lambda}^T g(\underline{x}) = x_1 + 3x_2 + \lambda(x_1^2 + x_2^2 - 10) \quad (1.22)$$

A necessary condition for \underline{x}^* to be a local extremum is that the first variation of J at \underline{x}^* is zero for all $\delta \underline{x}$:

$$\frac{\partial L(\underline{x}^*)}{\partial \underline{x}} = \begin{bmatrix} 1 + 2\lambda x_1 \\ 3 + 2\lambda x_2 \end{bmatrix} = 0 \text{ s.t. } x_1^2 + x_2^2 - 10 = 0 \quad (1.23)$$

As a consequence, the Lagrange multiplier λ shall be chosen as follows:

$$\begin{bmatrix} x_1 = -\frac{1}{2\lambda} \\ x_2 = -\frac{3}{2\lambda} \end{bmatrix} \Rightarrow x_1^2 + x_2^2 - 10 = \frac{1}{4\lambda^2} + \frac{9}{4\lambda^2} - 10 = 0 \Leftrightarrow 10 - 40\lambda^2 = 0 \Leftrightarrow \lambda = \pm \frac{1}{2} \quad (1.24)$$

Using the values of the Lagrange multiplier within (1.23) we then obtain 2 critical points:

$$\lambda = \frac{1}{2} \Rightarrow x_1^* = \begin{bmatrix} -1 \\ -3 \end{bmatrix} \text{ and } \lambda = -\frac{1}{2} \Rightarrow x_2^* = \begin{bmatrix} 1 \\ 3 \end{bmatrix} \quad (1.25)$$

– For $\lambda = \frac{1}{2}$ the bordered Hessian is:

$$\mathbf{H}_b(p) = \begin{bmatrix} 2\lambda - p & 0 & 2x_1 \\ 0 & 2\lambda - p & 2x_2 \\ 2x_1 & 2x_2 & 0 \end{bmatrix}_{\underline{x}=\underline{x}^*} = \begin{bmatrix} 1 - p & 0 & -2 \\ 0 & 1 - p & -6 \\ -2 & -6 & 0 \end{bmatrix} \quad (1.26)$$

Thus:

$$\det(\mathbf{H}_b(p)) = -40 + 40p \quad (1.27)$$

We conclude that the critical point $(-1; -3)$ is a local minima because $\det(\mathbf{H}_b(p)) = 0$ for $p = +1$ which is strictly positive.

– For $\lambda = -\frac{1}{2}$ the bordered Hessian is:

$$\mathbf{H}_b(p) = \begin{bmatrix} 2\lambda - p & 0 & 2x_1 \\ 0 & 2\lambda - p & 2x_2 \\ 2x_1 & 2x_2 & 0 \end{bmatrix}_{\underline{x}=\underline{x}^*} = \begin{bmatrix} -1 - p & 0 & 2 \\ 0 & -1 - p & 6 \\ 2 & 6 & 0 \end{bmatrix} \quad (1.28)$$

Thus:

$$\det(\mathbf{H}_b(p)) = 40 + 40p \quad (1.29)$$

We conclude that the critical point $(+1; +3)$ is a local maxima because $\det(\mathbf{H}_b(p)) = 0$ for $p = -1$ which is strictly negative.

1.6 Euler-Lagrange equation

Historically, Euler-Lagrange equation came with the study of the tautochrone (or isochrone curve) problem. Lagrange solved this problem in 1755 and sent the solution to Euler. Their correspondence ultimately led to the calculus of variations ².

The problem considered was to find the expression of $\underline{x}(t)$ which minimizes the following performance index $J(\underline{x}(t))$ where $F(\underline{x}(t), \dot{\underline{x}}(t))$ is a real-valued twice continuous function:

$$J(\underline{x}(t)) = \int_0^{t_f} F(\underline{x}(t), \dot{\underline{x}}(t)) dt \quad (1.30)$$

²https://en.wikipedia.org/wiki/Euler-Lagrange_equation

Furthermore the initial and final values of $\underline{x}(t)$ are imposed:

$$\begin{cases} \underline{x}(0) = \underline{x}_0 \\ \underline{x}(t_f) = \underline{x}_f \end{cases} \quad (1.31)$$

Let $\underline{x}^*(t)$ be a candidate for the minimization of $J(\underline{x}(t))$. In order to see whether $\underline{x}^*(t)$ is indeed an optimal solution, this candidate optimal input is perturbed by a small amount $\delta\underline{x}$ which leads to a perturbation $\delta\underline{x}$ in the optimal state vector $\underline{x}^*(t)$:

$$\begin{cases} \underline{x}(t) = \underline{x}^*(t) + \delta\underline{x}(t) \\ \dot{\underline{x}}(t) = \dot{\underline{x}}^*(t) + \delta\dot{\underline{x}}(t) \end{cases} \quad (1.32)$$

The change δJ in the value of the performance index is obtained thanks to the calculus of variation:

$$\delta J = \int_0^{t_f} \delta F(\underline{x}(t), \dot{\underline{x}}(t)) dt = \int_0^{t_f} \left(\frac{\partial F^T}{\partial \underline{x}} \delta \underline{x} + \frac{\partial F^T}{\partial \dot{\underline{x}}} \delta \dot{\underline{x}} \right) dt \quad (1.33)$$

Integrating $\frac{\partial F^T}{\partial \dot{\underline{x}}} \delta \dot{\underline{x}}$ by parts leads to the following expression:

$$\begin{aligned} \frac{d}{dt} \left(\frac{\partial F^T}{\partial \dot{\underline{x}}} \delta \underline{x} \right) &= \frac{d}{dt} \frac{\partial F^T}{\partial \dot{\underline{x}}} \delta \underline{x} + \frac{\partial F^T}{\partial \dot{\underline{x}}} \delta \dot{\underline{x}} \\ \Rightarrow \delta J &= \int_0^{t_f} \left(\frac{\partial F^T}{\partial \underline{x}} \delta \underline{x} - \frac{d}{dt} \frac{\partial F^T}{\partial \dot{\underline{x}}} \delta \underline{x} \right) dt + \frac{\partial F^T}{\partial \dot{\underline{x}}} \delta \underline{x} \Big|_0^{t_f} \end{aligned} \quad (1.34)$$

Because $\delta\underline{x}$ is a perturbation around the optimal state vector $\underline{x}^*(t)$ we shall set to zero the first variation δJ whatever the value of the variation $\delta\underline{x}$:

$$\delta J = 0 \quad \forall \delta \underline{x} \quad (1.35)$$

This leads to the following necessary conditions for optimality:

$$\begin{cases} \frac{\partial F^T}{\partial \underline{x}} \delta \underline{x} - \frac{d}{dt} \frac{\partial F^T}{\partial \dot{\underline{x}}} \delta \underline{x} = 0 \\ \frac{\partial F^T}{\partial \dot{\underline{x}}} \delta \underline{x} \Big|_0^{t_f} = 0 \end{cases} \quad (1.36)$$

As far as the initial and final values of $\underline{x}(t)$ are imposed no variation are permitted on $\delta\underline{x}$:

$$\begin{cases} \underline{x}(0) = \underline{x}_0 \\ \underline{x}(t_f) = \underline{x}_f \end{cases} \Rightarrow \begin{cases} \delta \underline{x}(0) = 0 \\ \delta \underline{x}(t_f) = 0 \end{cases} \quad (1.37)$$

On the other hand it is worth noticing that if the final value was not imposed we shall have $\frac{\partial F^T}{\partial \dot{\underline{x}}} \Big|_{t=t_f} = 0$.

Thus the first variation δJ of the functional cost reads:

$$\delta J = \int_0^{t_f} \left(\frac{\partial F^T}{\partial \underline{x}} \delta \underline{x} - \frac{d}{dt} \frac{\partial F^T}{\partial \dot{\underline{x}}} \delta \underline{x} \right) dt \quad (1.38)$$

In order to set to zero the first variation δJ whatever the value of the variation $\delta\underline{x}$ the following second-order partial differential equation has to be solved:

$$\frac{\partial F^T}{\partial \underline{x}} - \frac{d}{dt} \frac{\partial F^T}{\partial \dot{\underline{x}}} = 0 \quad (1.39)$$

Or by taking the transpose:

$$\frac{d}{dt} \frac{\partial F}{\partial \dot{x}} - \frac{\partial F}{\partial x} = 0 \quad (1.40)$$

We retrieve the well known Euler-Lagrange equation of classical mechanics.

Euler-Lagrange equation is second order Ordinary Differential Equations (ODE) which are usually very difficult to solve. They could be transformed into a set of first order Ordinary Differential Equations, which are much more convenient to solve, by introducing a control $u(t)$ defined by $\dot{x}(t) = u(t)$ and by using the Hamiltonian function H as it will be seen in the next sections.

Example 1.1. *Let's find the shortest distance between two points $P_1 = (x_1, y_1)$ and $P_2 = (x_2, y_2)$ in the euclidean plane.*

The length of the path between the two points is defined by:

$$J(y(x)) = \int_{P_1}^{P_2} \sqrt{dx^2 + dy^2} = \int_{x_1}^{x_2} \sqrt{1 + (y'(x))^2} dx \quad (1.41)$$

For that example $F(y(x), y'(x))$ reads:

$$F(y(x), y'(x)) = \sqrt{1 + \left(\frac{dy(x)}{dx}\right)^2} = \sqrt{1 + (y'(x))^2} \quad (1.42)$$

The initial and final values on $y(x)$ are imposed as follows:

$$\begin{cases} y(x_1) = y_1 \\ y(x_2) = y_2 \end{cases} \quad (1.43)$$

The Euler-Lagrange equation for this example reads:

$$\frac{d}{dx} \frac{\partial F}{\partial y'} - \frac{\partial F}{\partial y} = 0 \Leftrightarrow \frac{d}{dx} \frac{y'(x)}{\sqrt{1 + (y'(x))^2}} = 0 \quad (1.44)$$

From the preceding relationship it is clear that, denoting by c a constant, $y'(x)$ shall satisfy the following first order differential equation:

$$\begin{aligned} \frac{y'(x)}{\sqrt{1 + (y'(x))^2}} = c &\Rightarrow (y'(x))^2 = c^2 (1 + (y'(x))^2) \\ \Rightarrow (y'(x))^2 = \frac{c^2}{1 - c^2} &\Rightarrow y'(x) = \sqrt{\frac{c^2}{1 - c^2}} := a = \text{constant} \end{aligned} \quad (1.45)$$

Thus, the shortest distance between two fixed points in the euclidean plane is a curve with constant slope, that is a straight-line:

$$y(x) = ax + b \quad (1.46)$$

With initial and final values imposed on $y(x)$ we finally get for $y(x)$ the Lagrange polynomial of degree 1:

$$\begin{cases} y(x_1) = y_1 \\ y(x_2) = y_2 \end{cases} \Rightarrow y(x) = y_1 \frac{x - x_2}{x_1 - x_2} + y_2 \frac{x - x_1}{x_2 - x_1} \quad (1.47)$$

■

1.7 Fundamentals of optimal control theory

1.7.1 Problem to be solved

We first consider optimal control problems for general nonlinear *time invariant* systems of the form:

$$\begin{cases} \dot{\underline{x}} = f(\underline{x}, \underline{u}) \\ \underline{x}(0) = \underline{x}_0 \end{cases} \quad (1.48)$$

Where $\underline{x} \in \mathbb{R}^n$ and $\underline{u} \in \mathbb{R}^m$ are the state variable and control inputs, respectively, and $f(\underline{x}, \underline{u})$ is a continuous nonlinear function and \underline{x}_0 the initial conditions. The goal is to find a control \underline{u} that *minimizes* the following performance index:

$$J(\underline{u}(t)) = G(\underline{x}(t_f)) + \int_0^{t_f} F(\underline{x}(t), \underline{u}(t)) dt \quad (1.49)$$

Where:

- t is the current time and t_f the final time;
- $J(\underline{u}(t))$ is the integral cost function;
- $F(\underline{x}(t), \underline{u}(t))$ is the scalar running cost function;
- $G(\underline{x}(t_f))$ is the scalar terminal cost function.

Note that the state equation serves as constraints for the optimization of the performance index $J(\underline{u}(t))$. In addition, notice that the use of function $G(\underline{x}(t_f))$ is optional; indeed, if the final state $\underline{x}(t_f)$ is imposed then there is no need to insert the expression $G(\underline{x}(t_f))$ in the cost to be minimized.

1.7.2 Bolza, Mayer and Lagrange problems

The problem defined above is known as the Bolza problem. In the special case where $F(\underline{x}(t), \underline{u}(t)) = 0$ then the problem is known as the Mayer problem; on the other hand if $G(\underline{x}(t_f)) = 0$ the problem is known as the Lagrange problem.

The Bolza problem is equivalent to the Lagrange problem and in fact leads to it with the following change of variable:

$$\begin{cases} J_1(\underline{u}(t)) = \int_0^{t_f} (F(\underline{x}(t), \underline{u}(t)) + x_{n+1}(t)) dt \\ \dot{x}_{n+1}(t) = 0 \\ x_{n+1} = \frac{G(\underline{x}(t_f))}{t_f} \quad \forall t \end{cases} \quad (1.50)$$

It also leads to the Mayer problem if one sets:

$$\begin{cases} J_2(\underline{u}(t)) = G(\underline{x}(t_f)) + x_0(t_f) \\ \dot{x}_0(t) = F(\underline{x}(t), \underline{u}(t)) \\ x_0(0) = 0 \end{cases} \quad (1.51)$$

1.7.3 First order necessary conditions

The optimal control problem is then a constrained optimization problem, with cost being a functional of $\underline{u}(t)$ and the state equation providing the constraint equations. This optimal control problem can be converted to an unconstrained optimization problem of higher dimension by the use of Lagrange multipliers. An augmented performance index is then constructed by adding a vector of Lagrange multipliers $\underline{\lambda}$ times each constraint imposed by the differential equations driving the dynamics of the plant; these constraints are added to the performance index by the addition of an integral to form the augmented performance index J_a :

$$J_a(\underline{u}(t)) = G(\underline{x}(t_f)) + \int_0^{t_f} (F(\underline{x}(t), \underline{u}(t)) + \underline{\lambda}^T(t)(f(\underline{x}, \underline{u}) - \dot{\underline{x}})) dt \quad (1.52)$$

Let $\underline{u}^*(t)$ be a candidate for the optimal input vector, and let the corresponding state vector be $\underline{x}^*(t)$:

$$\dot{\underline{x}}^*(t) = f(\underline{x}^*(t), \underline{u}^*(t)) \quad (1.53)$$

In order to see whether $\underline{u}^*(t)$ is indeed an optimal solution, this candidate optimal input is perturbed by a small amount $\delta\underline{u}$ which leads to a perturbation $\delta\underline{x}$ in the optimal state vector $\underline{x}^*(t)$:

$$\begin{cases} \underline{u}(t) = \underline{u}^*(t) + \delta\underline{u}(t) \\ \underline{x}(t) = \underline{x}^*(t) + \delta\underline{x}(t) \end{cases} \quad (1.54)$$

Assuming that the final time t_f is known, the change δJ_a in the value of the augmented performance index is obtained thanks to the calculus of variation³:

$$\begin{aligned} \delta J_a &= \frac{\partial G(\underline{x}(t_f))}{\partial \underline{x}(t_f)}^T \delta \underline{x}(t_f) + \\ &\quad \int_0^{t_f} \left(\frac{\partial F}{\partial \underline{x}}^T \delta \underline{x} + \frac{\partial F}{\partial \underline{u}}^T \delta \underline{u} + \underline{\lambda}^T(t) \left(\frac{\partial f}{\partial \underline{x}} \delta \underline{x} + \frac{\partial f}{\partial \underline{u}} \delta \underline{u} - \frac{d\delta \underline{x}}{dt} \right) \right) dt \\ &= \frac{\partial G(\underline{x}(t_f))}{\partial \underline{x}(t_f)}^T \delta \underline{x}(t_f) + \\ &\quad \int_0^{t_f} \left(\left(\frac{\partial F}{\partial \underline{x}}^T + \underline{\lambda}^T(t) \frac{\partial f}{\partial \underline{x}} \right) \delta \underline{x} + \left(\frac{\partial F}{\partial \underline{u}}^T + \underline{\lambda}^T(t) \frac{\partial f}{\partial \underline{u}} \right) \delta \underline{u} - \underline{\lambda}^T(t) \frac{d\delta \underline{x}}{dt} \right) dt \end{aligned} \quad (1.55)$$

In the preceding equation:

- $\frac{\partial G(\underline{x}(t_f))}{\partial \underline{x}(t_f)}$, $\frac{\partial F}{\partial \underline{u}}^T$ and $\frac{\partial F}{\partial \underline{x}}^T$ are row vectors;
- $\frac{\partial f}{\partial \underline{x}}$ and $\frac{\partial f}{\partial \underline{u}}$ are matrices;
- $\frac{\partial f}{\partial \underline{x}} \delta \underline{x}$, $\frac{\partial f}{\partial \underline{u}} \delta \underline{u}$ and $\frac{d\delta \underline{x}}{dt}$ are column vectors.

Then we introduce the functional H , known as the *Hamiltonian function*, which is defined as follows:

$$\boxed{H(\underline{x}, \underline{u}, \underline{\lambda}) = F(\underline{x}, \underline{u}) + \underline{\lambda}^T(t) f(\underline{x}, \underline{u})} \quad (1.56)$$

³Ferguson J., Brief Survey of the History of the Calculus of Variations and its Applications (2004) arXiv:math/0402357

Then:

$$\begin{cases} \frac{\partial H^T}{\partial \underline{x}} = \frac{\partial F^T}{\partial \underline{x}} + \underline{\lambda}^T(t) \frac{\partial f}{\partial \underline{x}} \\ \frac{\partial H^T}{\partial \underline{u}} = \frac{\partial F^T}{\partial \underline{u}} + \underline{\lambda}^T(t) \frac{\partial f}{\partial \underline{u}} \end{cases} \quad (1.57)$$

Equation (1.55) becomes:

$$\delta J_a = \frac{\partial G(\underline{x}(t_f))^T}{\partial \underline{x}(t_f)} \delta \underline{x}(t_f) + \int_0^{t_f} \left(\frac{\partial H^T}{\partial \underline{x}} \delta \underline{x} + \frac{\partial H^T}{\partial \underline{u}} \delta \underline{u} - \underline{\lambda}^T(t) \frac{d\delta \underline{x}}{dt} \right) dt \quad (1.58)$$

Let's concentrate on the last term within the integral that we integrate by parts:

$$\begin{aligned} \int_0^{t_f} \underline{\lambda}^T(t) \frac{d\delta \underline{x}}{dt} dt &= \underline{\lambda}^T(t) \delta \underline{x} \Big|_0^{t_f} - \int_0^{t_f} \dot{\underline{\lambda}}^T(t) \delta \underline{x} dt \\ \Leftrightarrow \int_0^{t_f} \underline{\lambda}^T(t) \frac{d\delta \underline{x}}{dt} dt &= \underline{\lambda}^T(t_f) \delta \underline{x}(t_f) - \underline{\lambda}^T(0) \delta \underline{x}(0) - \int_0^{t_f} \dot{\underline{\lambda}}^T(t) \delta \underline{x} dt \end{aligned} \quad (1.59)$$

As far as the initial state is imposed, the variation of the initial condition is null; consequently we have $\delta \underline{x}(0) = 0$ and:

$$\int_0^{t_f} \underline{\lambda}^T(t) \frac{d\delta \underline{x}}{dt} dt = \underline{\lambda}^T(t_f) \delta \underline{x}(t_f) - \int_0^{t_f} \dot{\underline{\lambda}}^T(t) \delta \underline{x} dt \quad (1.60)$$

Using (1.60) within (1.58) leads to the following expression for the first variation of the augmented functional cost:

$$\begin{aligned} \delta J_a &= \left(\frac{\partial G(\underline{x}(t_f))^T}{\partial \underline{x}(t_f)} - \underline{\lambda}^T(t_f) \right) \delta \underline{x}(t_f) + \\ &\int_0^{t_f} \left(\frac{\partial H^T}{\partial \underline{u}} \delta \underline{u} + \left(\frac{\partial H^T}{\partial \underline{x}} + \dot{\underline{\lambda}}^T(t) \right) \delta \underline{x} \right) dt \end{aligned} \quad (1.61)$$

In order to set the first variation of the augmented functional cost δJ_a to zero the time dependant Lagrange multipliers $\underline{\lambda}(t)$, which are also called costate functions, are chosen as follows:

$$\boxed{\dot{\underline{\lambda}}^T(t) + \frac{\partial H^T}{\partial \underline{x}} = 0 \Leftrightarrow \dot{\underline{\lambda}}(t) = -\frac{\partial H}{\partial \underline{x}}} \quad (1.62)$$

This equation is called the adjoint equation. As far as it is a differential equation we need to know the value of $\underline{\lambda}(t)$ at a specific value of time t to be able to compute its solution (also called its *trajectory*) :

- Assuming that final value $\underline{x}(t_f)$ is specified to be \underline{x}_f then the variation $\delta \underline{x}(t_f)$ in (1.61) is zero and $\underline{\lambda}(t_f)$ is set such that $\underline{x}(t_f) = \underline{x}_f$.
- Assuming that final value $\underline{x}(t_f)$ is *not* specified then the variation $\delta \underline{x}(t_f)$ in (1.61) is not equal to zero and the value of $\underline{\lambda}(t_f)$ is set by imposing that the following difference vanishes at final time t_f :

$$\boxed{\frac{\partial G(\underline{x}(t_f))^T}{\partial \underline{x}(t_f)} - \underline{\lambda}^T(t_f) = 0 \Leftrightarrow \underline{\lambda}(t_f) = \frac{\partial G(\underline{x}(t_f))}{\partial \underline{x}(t_f)}} \quad (1.63)$$

This is the boundary condition, also known as transversality condition, which set the final value of the Lagrange multipliers.

Hence in both situations the first variation of the augmented functional cost (1.61) can be written as:

$$\delta J_a = \int_0^{t_f} \left(\frac{\partial H^T}{\partial \underline{u}} \delta \underline{u} \right) dt \quad (1.64)$$

1.7.4 Hamilton-Jacobi-Bellman (HJB) partial differential equation

Let $J^*(\underline{x}, t)$ be the optimal cost-to-go function between t and t_f :

$$J^*(\underline{x}, t) = \min_{\underline{u}(t) \in \mathcal{U}} \int_t^{t_f} F(\underline{x}(\tau), \underline{u}(\tau)) d\tau \quad (1.65)$$

The Hamilton-Jacobi-Bellman equation related to the optimal control problem (1.49) under the constraint (1.48) is the following first order partial derivative equation⁴:

$$-\frac{\partial J^*(\underline{x}, t)}{\partial t} = \min_{\underline{u}(t) \in \mathcal{U}} \left(F(\underline{x}, \underline{u}) + \frac{\partial J^*(\underline{x}, t)}{\partial \underline{x}} f(\underline{x}, \underline{u}) \right) \quad (1.66)$$

or, equivalently:

$$-\frac{\partial J^*(\underline{x}, t)}{\partial t} = H^* \left(\frac{\partial J^*(\underline{x}, t)}{\partial \underline{x}}, \underline{x}(t) \right) \quad (1.67)$$

where

$$H^*(\lambda(t), \underline{x}(t)) = \min_{\underline{u}(t) \in \mathcal{U}} \left(F(\underline{x}, \underline{u}) + \frac{\partial J^*(\underline{x}, t)}{\partial \underline{x}} f(\underline{x}, \underline{u}) \right) \quad (1.68)$$

For the time-dependent case, the terminal condition on the optimal cost-to-go function solution of (1.66) reads:

$$J^*(\underline{x}, t_f) = G(\underline{x}(t_f)) \quad (1.69)$$

Those relationships lead to the so-called dynamic programming approach which has been introduced by Bellman⁵ in 1957. This is a very powerful result which encompasses both necessary and sufficient conditions for optimality. Nevertheless it may be difficult to use in practice because it involves to find the solution of a partial derivative equation.

It is worth noticing that the Lagrange multiplier $\lambda(t)$ represents the partial derivative with respect to the state of the optimal cost-to-go function⁶:

$$\lambda(t) = \left(\frac{\partial J^*(\underline{x}, t)}{\partial \underline{x}} \right)^T \quad (1.70)$$

⁴da Silva J., de Sousa J., Dynamic Programming Techniques for Feedback Control, Proceedings of the 18th World Congress, Milano (Italy) August 28 - September 2, 2011

⁵Bellman R., Dynamic programming, Princeton University Press, 1957

⁶Alazard D., Optimal Control & Guidance: From Dynamic Programming to Pontryagin's Minimum Principle, lecture notes

1.8 Unconstrained control

If there is no constraint on input $\underline{u}(t)$, then $\delta\underline{u}$ is free and the first variation of the augmented functional cost δJ_a in (1.64) is set to zero through the following necessary condition for optimality:

$$\delta J_a = 0 \Rightarrow \frac{\partial H^T}{\partial \underline{u}} = 0 \Leftrightarrow \frac{\partial H}{\partial \underline{u}} = 0 \quad (1.71)$$

For an autonomous system, the function $f()$ is not an explicit function of time. From (1.56) we get:

$$\frac{dH}{dt} = \frac{\partial H^T}{\partial \underline{x}} \frac{d\underline{x}}{dt} + \frac{\partial H^T}{\partial \underline{u}} \frac{d\underline{u}}{dt} + \frac{\partial H^T}{\partial \underline{\lambda}} \frac{d\underline{\lambda}}{dt} \quad (1.72)$$

According to (1.48), (1.56) and (1.62) we have

$$\begin{cases} \dot{\underline{\lambda}}^T(t) = -\frac{\partial H^T}{\partial \underline{x}} \\ \frac{\partial H^T}{\partial \underline{\lambda}} = f^T = \dot{\underline{x}}^T \end{cases} \Rightarrow \frac{dH}{dt} = -\dot{\underline{\lambda}}^T(t) \frac{d\underline{x}}{dt} + \frac{\partial H^T}{\partial \underline{u}} \frac{d\underline{u}}{dt} + \dot{\underline{x}}^T \frac{d\underline{\lambda}}{dt} \quad (1.73)$$

Having in mind that the Hamiltonian H is a scalar functional we get:

$$\dot{\underline{\lambda}}^T(t) \frac{d\underline{x}}{dt} = \dot{\underline{x}}^T(t) \frac{d\underline{\lambda}}{dt} \Rightarrow \frac{dH}{dt} = \frac{\partial H^T}{\partial \underline{u}} \frac{d\underline{u}}{dt} \quad (1.74)$$

Finally, assuming no constraint on input $\underline{u}(t)$, we use (1.71) to obtain the following result:

$$\boxed{\frac{\partial H}{\partial \underline{u}} = 0 \Rightarrow \frac{dH}{dt} = 0} \quad (1.75)$$

In other words, for an autonomous system Hamiltonian functional H remains constant along an optimal trajectory.

Example 1.2. As in example 1.1 we consider again the problem of finding the shortest distance between two points $P_1 = (x_1, y_1)$ and $P_2 = (x_2, y_2)$ in the euclidean plane.

Setting $u(x) = y'(x)$ the length of the path between the two points is defined by:

$$J(u(x)) = \int_{P_1}^{P_2} \sqrt{dx^2 + dy^2} = \int_{x_1}^{x_2} \sqrt{1 + u(x)^2} dx \quad (1.76)$$

Here $J(u(x))$ is the performance index to be minimized under the following constraints:

$$\begin{cases} y'(x) = u(x) \\ y(x_1) = y_1 \\ y(x_2) = y_2 \end{cases} \quad (1.77)$$

Let $\lambda(x)$ be the Lagrange multiplier, which is here a scalar. The Hamiltonian H reads:

$$H = \sqrt{1 + u^2(x)} + \lambda(x)u(x) \quad (1.78)$$

The necessary conditions for optimality are the following:

$$\begin{cases} \frac{\partial H}{\partial y} = -\lambda'(x) \Leftrightarrow \lambda'(x) = 0 \\ \frac{\partial H}{\partial u} = 0 \Leftrightarrow \frac{u(x)}{\sqrt{1+u^2(x)}} + \lambda(x) = 0 \end{cases} \quad (1.79)$$

Denoting by c a constant we get from the first equation of (1.79):

$$\lambda(x) = c \quad (1.80)$$

Using this relationship in the second equation of (1.79) leads to the following expression of $u(x)$ where constant a is introduced:

$$\frac{u(x)}{\sqrt{1+u^2(x)}} + c = 0 \Rightarrow u^2(x) = \frac{c^2}{1-c^2} \Rightarrow u(x) = \sqrt{\frac{c^2}{1-c^2}} := a = \text{constant} \quad (1.81)$$

Thus, the shortest distance between two fixed points in the euclidean plane is a curve with constant slope, that is a straight-line:

$$y(x) = ax + b \quad (1.82)$$

We obviously retrieve the result of example 1.1. ■

1.9 Constrained control - Pontryagin's principle

In this section we consider the optimal control problem with control-state constraints. More specifically we consider the problem of finding a control \underline{u} that *minimizes* the following performance index:

$$J(\underline{u}(t)) = G(\underline{x}(t_f)) + \int_0^{t_f} F(\underline{x}(t), \underline{u}(t)) dt \quad (1.83)$$

Under the following constraints:

- Dynamics and boundary conditions:

$$\begin{cases} \dot{\underline{x}} = f(\underline{x}, \underline{u}) \\ \underline{x}(0) = \underline{x}_0 \end{cases} \quad (1.84)$$

- Mixed control-state constraints:

$$c(\underline{x}, \underline{u}) \leq 0, \text{ where } c(\underline{x}, \underline{u}) : \mathbb{R}^n \times \mathbb{R}^m \rightarrow \mathbb{R} \quad (1.85)$$

Usually a slack variable $\alpha(t)$, which is actually a new control variable, is introduced in order to convert the preceding inequality constraint into an equality constraint:

$$c(\underline{x}, \underline{u}) + \alpha^2(t) = 0, \text{ where } \alpha(t) : \mathbb{R} \rightarrow \mathbb{R} \quad (1.86)$$

To solve this problem we introduce the *augmented Hamiltonian function* $H_a(\underline{x}, \underline{u}, \underline{\lambda}, \underline{\mu})$ which is defined as follows ⁷:

$$\begin{aligned} H_a(\underline{x}, \underline{u}, \underline{\lambda}, \underline{\mu}, \alpha) &= H(\underline{x}, \underline{u}, \underline{\lambda}) + \underline{\mu} (c(\underline{x}, \underline{u}) + \alpha^2) \\ &= F(\underline{x}, \underline{u}) + \underline{\lambda}^T(t) f(\underline{x}, \underline{u}) + \underline{\mu}(t) (c(\underline{x}, \underline{u}) + \alpha^2) \end{aligned} \quad (1.87)$$

Then the Pontryagin's principle states that the optimal control \underline{u}^* must satisfy the following conditions:

- Adjoint equation and transversality condition:

$$\begin{cases} \dot{\underline{\lambda}}(t) = -\frac{\partial H_a}{\partial \underline{x}} \\ \underline{\lambda}(t_f) = \frac{\partial G(\underline{x}(t_f))}{\partial \underline{x}(t_f)} \end{cases} \quad (1.88)$$

- Local minimum condition for augmented Hamiltonian:

$$\begin{cases} \frac{\partial H_a}{\partial \underline{u}} = 0 \\ \frac{\partial H_a}{\partial \alpha} = 0 \Rightarrow 2\underline{\mu}\alpha = 0 \end{cases} \quad (1.89)$$

- Sign of multiplier $\underline{\mu}(t)$ and complementarity condition: the equation $\frac{\partial H_a}{\partial \alpha} = 0$ implies $2\underline{\mu}\alpha = 0$. Thus either $\underline{\mu} = 0$, which is an off-boundary arc, or $\alpha = 0$ which is an on-boundary arc:

- For the off-boundary arc where $\underline{\mu} = 0$ control \underline{u} is obtained from $\frac{\partial H_a}{\partial \underline{u}} = 0$ and α from the equality constraint $c(\underline{x}, \underline{u}) + \alpha^2 = 0$;
- For the on-boundary arc where $\alpha = 0$ control \underline{u} is obtained from equality constraint $c(\underline{x}, \underline{u}) = 0$. Indeed there always exists a smooth function $\underline{u}_b(\underline{x})$ called boundary control which satisfies:

$$c(\underline{x}, \underline{u}_b(\underline{x})) = 0 \quad (1.90)$$

Then multiplier $\underline{\mu}$ is obtained from $\frac{\partial H_a}{\partial \underline{u}} = 0$:

$$0 = \frac{\partial H_a}{\partial \underline{u}} = \frac{\partial H}{\partial \underline{u}} + \underline{\mu} \frac{\partial c(\underline{x}, \underline{u})}{\partial \underline{u}} \Rightarrow \underline{\mu} = - \left. \frac{\frac{\partial H_a}{\partial \underline{u}}}{\frac{\partial c(\underline{x}, \underline{u})}{\partial \underline{u}}} \right|_{\underline{u}=\underline{u}_b(\underline{x})} \quad (1.91)$$

- Weierstrass conditions (proposed in 1879) for a variational extremum: it states that optimal control \underline{u}^* and α^* within the *augmented Hamiltonian function* H_a must satisfy the following condition for a minimum at every point of the optimal path:

$$H_a(\underline{x}^*, \underline{u}^*, \underline{\lambda}^*, \underline{\mu}^*, \alpha^*) - H_a(\underline{x}^*, \underline{u}, \underline{\lambda}^*, \underline{\mu}^*, \alpha) < 0 \quad (1.92)$$

Since $c(\underline{x}, \underline{u}) + \alpha^2(t) = 0$ the Weierstrass conditions for a variational extremum can be rewritten as a function of the *Hamiltonian function* H and the inequality constraint:

$$\begin{cases} H(\underline{x}^*, \underline{u}^*, \underline{\lambda}^*) - H(\underline{x}^*, \underline{u}, \underline{\lambda}^*) < 0 \\ c(\underline{x}^*, \underline{u}^*) \leq 0 \end{cases} \quad (1.93)$$

⁷Hull D. G., *Optimal Control Theory for Applications*, Springer (2003)

For a problem where the *Hamiltonian function* H is linear in the control \underline{u} and where \underline{u} is limited between \underline{u}_{min} and \underline{u}_{max} Pontryagin's principle indicates that the first variation of the augmented functional cost δJ_a in (1.64) will remain positive (i.e. J_a is minimized) through the following necessary condition for optimality:

$$\begin{cases} \underline{u}_{min} \leq \underline{u}(t) \leq \underline{u}_{max} \\ \delta J_a \geq 0 \end{cases} \Rightarrow \begin{cases} \underline{u}(t) = \underline{u}_{max} & \text{if } \frac{\partial H}{\partial \underline{u}} < 0 \\ \underline{u}(t) = \underline{u}_{min} & \text{if } \frac{\partial H}{\partial \underline{u}} > 0 \end{cases} \quad (1.94)$$

Thus the control $\underline{u}(t)$ switches from \underline{u}_{max} to \underline{u}_{min} at times when $\partial H/\partial \underline{u}$ switches from negative to positive (or vice-versa). This type of control where the control is always on the boundary is called *bang-bang control*.

In addition, and as the unconstrained control case, the *Hamiltonian functional* H remains constant along an optimal trajectory for an autonomous system when there are constraints on input $\underline{u}(t)$. Indeed in that situation control $\underline{u}(t)$ is constant (it is set either to its minimum or maximum value) and consequently $\frac{d\underline{u}}{dt}$ is zero. From (1.74) we get $\frac{dH}{dt} = 0$.

1.10 Bang-bang control examples

1.10.1 Example 1

Consider a simple mass m which moves on the x -axis and is subject to a force $f(t)$ ⁸. Equation of motion reads:

$$m\ddot{y}(t) = f(t) \quad (1.95)$$

We set control $u(t)$ as:

$$u(t) = \frac{f(t)}{m} \quad (1.96)$$

Consequently the equation of motion reduces to:

$$\ddot{y}(t) = u(t) \quad (1.97)$$

The state space realization of this system is the following:

$$\begin{cases} \dot{x}_1(t) = x_2(t) \\ \dot{x}_2(t) = u(t) \end{cases} \Rightarrow \begin{cases} \dot{x}_1(t) = x_2(t) \\ \dot{x}_2(t) = u(t) \end{cases} \Leftrightarrow f(x, u) = \begin{bmatrix} x_2(t) \\ u(t) \end{bmatrix} \quad (1.98)$$

We will assume that the initial position of the mass is zero and that the movement starts from rest:

$$\begin{cases} y(0) = 0 \\ \dot{y}(0) = 0 \end{cases} \quad (1.99)$$

We will assume that control $u(t)$ is subject to the following constraint:

$$\underline{u}_{min} \leq u(t) \leq \underline{u}_{max} \quad (1.100)$$

⁸ Linear Systems: Optimal and Robust Control 1st Edition, by Alok Sinha, CRC Press

First we are looking for the optimal control $u(t)$ which enables the mass to cover the maximum distance in a fixed time t_f :

The objective of the problem is to maximize $y(t_f)$. This corresponds to minimize the opposite of $y(t_f)$; consequently the cost $J(u(t))$ reads as follows where $F(x, u) = 0$ when compared to (1.49):

$$J(u(t)) = G(x(t_f)) = -y(t_f) := -x_1(t_f) \quad (1.101)$$

As $F(x, u) = 0$ the Hamiltonian for this problem reads:

$$H(x, u, \lambda) = \lambda(t)^T f(x, u) = [\lambda_1(t) \quad \lambda_2(t)] \begin{bmatrix} x_2(t) \\ u(t) \end{bmatrix} = \lambda_1(t)x_2(t) + \lambda_2(t)u(t) \quad (1.102)$$

Adjoint equation is:

$$\dot{\lambda}(t) = -\frac{\partial H}{\partial x} \Leftrightarrow \begin{cases} \dot{\lambda}_1(t) = -\frac{\partial H}{\partial x_1} = 0 \\ \dot{\lambda}_2(t) = -\frac{\partial H}{\partial x_2} = -\lambda_1(t) \end{cases} \quad (1.103)$$

Solutions of adjoint equations are the following where c and D are constants:

$$\begin{cases} \lambda_1(t) = c \\ \lambda_2(t) = -ct + d \end{cases} \quad (1.104)$$

As far as final time t_f is not specified values of constants c and d are determined by transversality condition (1.63):

$$\lambda(t_f) = \frac{\partial G(x(t_f))}{\partial x(t_f)} \Leftrightarrow \begin{cases} \lambda_1(t_f) = \frac{\partial(-x_1(t_f))}{\partial x_1(t_f)} = -1 \\ \lambda_2(t_f) = \frac{\partial(-x_1(t_f))}{\partial x_2(t_f)} = 0 \end{cases} \quad (1.105)$$

And consequently:

$$\begin{cases} c = -1 \\ d = -t_f \end{cases} \Rightarrow \begin{cases} \lambda_1(t) = -1 \\ \lambda_2(t) = t - t_f \end{cases} \quad (1.106)$$

Thus the Hamiltonian H reads as follows:

$$H(x, u, \lambda) = \lambda_1(t)x_2(t) + \lambda_2(t)u(t) = -x_2(t) + (t - t_f)u(t) \quad (1.107)$$

Then $\frac{\partial H}{\partial u} = t - t_f \leq 0 \forall 0 \leq t \leq t_f$. Applying (1.94) leads to the expression of control $u(t)$:

$$\frac{\partial H}{\partial u} \leq 0 \Rightarrow u(t) = u_{max} \quad \forall 0 \leq t \leq t_f \quad (1.108)$$

This is of common sense when the objective is to cover the maximum distance in a fixed time without any constraint on the vehicle velocity at the final time. The optimal state trajectory can be easily obtained by solving the state equations with given initial conditions:

$$\begin{cases} \dot{x}_1 = x_2 \\ \dot{x}_2 = u_{max} \end{cases} \Rightarrow \begin{cases} x_1(t) = \frac{1}{2}u_{max}t^2 \\ x_2(t) = u_{max}t \end{cases} \quad (1.109)$$

The Hamiltonian along the optimal trajectory has the following value:

$$H(x, u, \lambda) = \lambda_1(t)x_2(t) + \lambda_2(t)u(t) = -u_{max}t + (t - t_f)u_{max} = -u_{max}t_f \quad (1.110)$$

As expected the Hamiltonian along the optimal trajectory is constant. The minimum value of the performance index is:

$$J(u(t)) = -x_1(t_f) = -\frac{1}{2}u_{max}t_f^2 \quad (1.111)$$

1.10.2 Example 2

We re-use the preceding example but now we are looking for the optimal control $u(t)$ which enables the mass to cover the maximum distance in a fixed time t_f with the additional constraint that the final velocity is equal to zero:

$$x_2(t_f) = 0 \quad (1.112)$$

The solution of this problem starts as in the previous case and leads to the solution of adjoint equations where c and d are constants:

$$\begin{cases} \lambda_1(t) = c \\ \lambda_2(t) = -ct + d \end{cases} \quad (1.113)$$

The difference when compared with the previous case is that now the final velocity is equal to zero, that is $x_2(t_f) = 0$. Consequently transversality condition (1.63) involves only state x_1 and reads as follows:

$$\lambda(t_f) = \frac{\partial G(x(t_f))}{\partial x(t_f)} \Leftrightarrow \lambda_1(t_f) = \frac{\partial(-x_1(t_f))}{\partial x_1(t_f)} = -1 \quad (1.114)$$

Taking into account (1.114) into (1.113) leads to:

$$\begin{cases} \lambda_1(t) = -1 \\ \lambda_2(t) = t + d \end{cases} \quad (1.115)$$

The Hamiltonian H reads as follows:

$$H(x, u, \lambda) = \lambda_1(t)x_2(t) + \lambda_2(t)u(t) = -x_2(t) + (t + d)u(t) \quad (1.116)$$

Thus $\frac{\partial H}{\partial u} = t + d = \lambda_2(t) \forall 0 \leq t \leq t_f$ where the value of constant d is not known: it can be either $d < -t_f$, $d \in [-t_f, 0]$ or $d > 0$. Figure 1.1 plots the three possibilities.

- The possibility $d < -t_f$ leads to $u(t) = u_{min} \forall t \in [0, t_f]$ according to (1.94), that is $y(t) := x_1(t) = 0.5u_{min}t^2$ when taking into account initial conditions (1.99). Thus there is no way to achieve the constraint that the velocity is zero at instant t_f and the possibility $d < -t_f$ is ruled out;
- Similarly, the possibility $d > 0$ leads to $u(t) = u_{max} \forall t \in [0, t_f]$, that is $y(t) := x_1(t) = 0.5u_{max}t^2$ when taking into account initial conditions (1.99). Thus the possibility $d > 0$ is also ruled out.

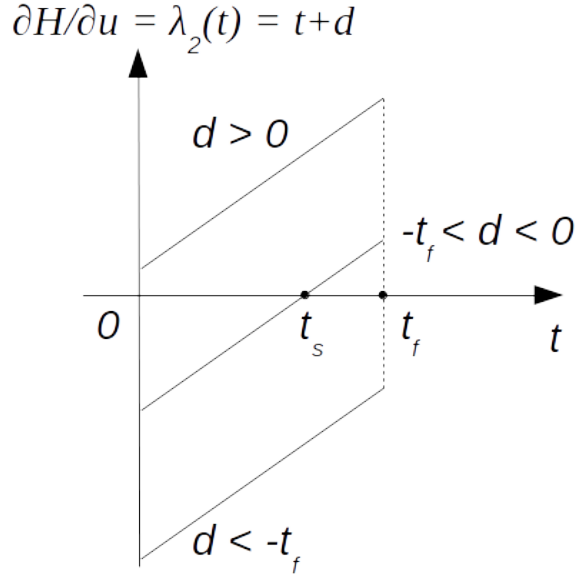

Figure 1.1: Three possibilities for the values of $\partial H/\partial u = \lambda_2(t)$

Hence d shall be chosen between $-t_f$ and 0 . According to (1.94) and Figure 1.1 we have:

$$u(t) = \begin{cases} u_{max} & \forall 0 \leq t \leq t_s \\ u_{min} & \forall t_s < t \leq t_f \end{cases} \quad (1.117)$$

Instant t_s is the switching instant, that is time at which $\frac{\partial H}{\partial u} = \lambda_2(t)$ changes in sign. Solving the state equations with initial velocity set to zero yields the expression of $x_2(t) \forall t_s < t \leq t_f$:

$$\begin{aligned} & \begin{cases} \dot{x}_2 = u_{max} & \forall 0 \leq t \leq t_s \\ \dot{x}_2 = u_{min} & \forall t_s < t \leq t_f \\ x_2(0) = 0 \end{cases} \\ \Rightarrow & \begin{cases} x_2(t_s) = u_{max}t_s \\ x_2(t) = u_{max}t_s + u_{min}(t - t_s) & \forall t_s < t \leq t_f \end{cases} \end{aligned} \quad (1.118)$$

Imposing $x_2(t_f) = 0$ leads to the value of the switching instant t_s :

$$\begin{aligned} x_2(t_f) = 0 & \Rightarrow u_{max}t_s + u_{min}(t_f - t_s) = 0 \\ \Rightarrow t_s & = \frac{u_{min}t_f}{u_{min} - u_{max}} = -\frac{u_{min}t_f}{u_{max} - u_{min}} \end{aligned} \quad (1.119)$$

From Figure 1.1 it is clear that at $t = t_s$ we have $\lambda_2(t_s) = 0$. Using the fact that $\lambda_2(t) = t + d$ we finally get the value of constant d :

$$\begin{cases} \lambda_2(t) = t + d \\ \lambda_2(t_s) = 0 \end{cases} \Rightarrow d = -t_s \quad (1.120)$$

Furthermore the Hamiltonian along the optimal trajectory has the following

value:

$$\left\{ \begin{array}{l} \forall 0 \leq t \leq t_s \quad H(x, u, \lambda) = \lambda_1(t)x_2(t) + \lambda_2(t)u(t) \\ \qquad \qquad \qquad \qquad \qquad \qquad = -u_{max}t + (t+d)u_{max} = -t_s u_{max} \\ \forall t_s < t \leq t_f \quad H(x, u, \lambda) = -u_{max}t_s - u_{min}(t-t_s) + (t-t_s)u_{max} \\ \qquad \qquad \qquad \qquad \qquad \qquad = -t_s u_{max} \end{array} \right. \quad (1.121)$$

As expected the Hamiltonian along the optimal trajectory is constant.

1.11 Free final time

It is worth noticing that if final time t_f is not specified, and after having noticed that $f(t_f) - \dot{\underline{x}}(t_f) = 0$, the following term shall be added to δJ_a in (1.55):

$$\left(F(t_f) + \frac{\partial G(\underline{x}(t_f))^T}{\partial \underline{x}} f(t_f) \right) \delta t_f \quad (1.122)$$

In this case the first variation of the augmented performance index with respect to δt_f is zero as soon as:

$$F(t_f) + \frac{\partial G(\underline{x}(t_f))^T}{\partial \underline{x}} f(t_f) = 0 \quad (1.123)$$

As far as boundary conditions (1.63) apply we get:

$$\underline{\lambda}(t_f) = \frac{\partial G(\underline{x}(t_f))}{\partial \underline{x}(t_f)} \Rightarrow F(t_f) + \underline{\lambda}(t_f)f(t_f) = 0 \quad (1.124)$$

The preceding equation is called transversality condition. We recognize in $F(t_f) + \underline{\lambda}(t_f)f(t_f)$ the value of the *Hamiltonian function* $H(t)$ defined in (1.56) at final time t_f . Because the Hamiltonian $H(t)$ is constant along an optimal trajectory for an autonomous system (see (1.75)) it is concluded that $H(t) = 0$ along an optimal trajectory for an autonomous system when final time t_f is free.

Alternatively we can introduce a new variable, denoted s for example, which is related to time t as follows:

$$t(s) = t_0 + (t_f - t_0)s \quad \forall s \in [0, 1] \quad (1.125)$$

From the preceding equation we get:

$$dt = (t_f - t_0) ds \quad (1.126)$$

Then the optimal control problem with respect to time t where the final time t_f is free is changed into an optimal control problem with respect to new variable s and an additional state $t_f(s)$ which is constant with respect to s . The optimal control problem reads:

Minimize:

$$J(\underline{u}(s)) = G(\underline{x}(1)) + \int_0^1 (t_f(s) - t_0) F(\underline{x}(s), \underline{u}(s)) ds \quad (1.127)$$

Under the following constraints:

– Dynamics and boundary conditions:

$$\begin{cases} \frac{d}{ds}\underline{x}(s) = \frac{d\underline{x}(t)}{dt} \frac{dt}{ds} = (t_f(s) - t_0)f(\underline{x}(s), \underline{u}(s)) \\ \frac{d}{ds}t_f(s) = 0 \\ \underline{x}(0) = \underline{x}_0 \end{cases} \quad (1.128)$$

– Mixed control-state constraints:

$$c(\underline{x}(s), \underline{u}(s)) \leq 0, \text{ where } c(\underline{x}(s), \underline{u}(s)) : \mathbb{R}^n \times \mathbb{R}^m \rightarrow \mathbb{R} \quad (1.129)$$

1.12 Singular arc - Legendre-Clebsch condition

The case where $\partial H/\partial \underline{u}$ does not yield to a definite value for the control $\underline{u}(t)$ is called *singular* control. Usually singular control arises when a multiplier $\sigma(t)$ of the control $\underline{u}(t)$ (which is called the switching function) in the Hamiltonian H vanishes over a finite length of time $t_1 \leq t \leq t_2$:

$$\sigma(t) := \frac{\partial H}{\partial \underline{u}} = 0 \quad \forall t_1 \leq t \leq t_2 \quad (1.130)$$

The *singular* control can be determined by the condition that the switching function $\sigma(t)$ and its time derivatives vanish along the so-called singular arc. Hence over a singular arc we have:

$$\frac{d^k}{dt^k}\sigma(t) = 0 \quad \forall t_1 \leq t \leq t_2, \quad \forall k \in \mathbb{N} \quad (1.131)$$

At some derivative order the control $\underline{u}(t)$ does appear explicitly and its value is thereby determined. Furthermore it can be shown that the control $\underline{u}(t)$ appears at an even derivative order. So the derivative order at which the control $\underline{u}(t)$ does appear explicitly will be denoted $2q$. Thus:

$$k := 2q \Rightarrow \frac{d^{2q}\sigma(t)}{dt^{2q}} := A(t, \underline{x}, \underline{\lambda}) + B(t, \underline{x}, \underline{\lambda})\underline{u} = 0 \quad (1.132)$$

The previous equation gives an explicit equation for the singular control, once the Lagrange multiplier $\underline{\lambda}$ have been obtained through the relationship $\underline{\dot{\lambda}}(t) = -\frac{\partial H}{\partial \underline{x}}$.

The singular arc will be optimal if it satisfies the following generalized Legendre-Clebsch condition, which is also known as the Kelley condition⁹, where $2q$ is the (always even) value of k at which the control $\underline{u}(t)$ explicitly appears in $\frac{d^k}{dt^k}\sigma(t)$ for the first time:

$$(-1)^q \frac{\partial}{\partial \underline{u}} \left[\frac{d^{2q}\sigma(t)}{dt^{2q}} \right] \geq 0 \quad (1.133)$$

⁹Douglas M. Pargett & Douglas Mark D. Ardema, Flight Path Optimization at Constant Altitude, Journal of Guidance Control and Dynamics, July 2007, 30(4):1197-1201, DOI: 10.2514/1.28954

Note that for the *regular* arc the second order necessary condition for optimality to achieve a minimum cost is the positive semi-definiteness of the Hessian matrix of the Hamiltonian along an optimal trajectory. This condition is obtained by setting $q = 0$ in the generalized Legendre-Clebsch condition (1.133):

$$q = 0 \Rightarrow \frac{\partial}{\partial \underline{u}} \sigma(t) = \frac{\partial^2 H}{\partial \underline{u}^2} = \mathbf{H}_{uu} \geq 0 \quad (1.134)$$

This inequality is also termed *regular* Legendre-Clebsch condition.

Chapter 2

Finite Horizon Linear Quadratic Regulator

2.1 Problem to be solved

The Linear Quadratic Regulator (*LQR*) is an optimal control problem where the state equation of the plant is linear, the performance index is quadratic and the initial conditions are known. We discuss in this chapter linear quadratic regulation in the case where the final time which appears in the cost to be minimized is finite whereas the next chapter will focus on the infinite horizon case. The optimal control problem to be solved is the following: assume a plant driven by a linear dynamical equation of the form:

$$\begin{cases} \dot{\underline{x}}(t) = \mathbf{A}\underline{x}(t) + \mathbf{B}\underline{u}(t) \\ \underline{x}(0) = \underline{x}_0 \end{cases} \quad (2.1)$$

Where:

- \mathbf{A} is the state (or system) matrix
- \mathbf{B} is the input matrix
- $\underline{x}(t)$ is the state vector of dimension n
- $\underline{u}(t)$ is the control vector of dimension m

Then we have to find the control $\underline{u}(t)$ which minimizes the following quadratic performance index:

$$J(\underline{u}(t)) = \frac{1}{2} (\underline{x}(t_f) - \underline{x}_f)^T \mathbf{S} (\underline{x}(t_f) - \underline{x}_f) + \frac{1}{2} \int_0^{t_f} \underline{x}^T(t) \mathbf{Q} \underline{x}(t) + \underline{u}^T(t) \mathbf{R} \underline{u}(t) dt \quad (2.2)$$

where the final time t_f is set and \underline{x}_f is the final state to be reached. The performance index relates to the fact that a trade-off has been done between the rate of variation of $\underline{x}(t)$ and the magnitude of the control input $\underline{u}(t)$. Matrices

\mathbf{S} and \mathbf{Q} shall be chosen to be symmetric positive semi-definite and matrix \mathbf{R} symmetric positive definite.

$$\begin{cases} \mathbf{S} = \mathbf{S}^T \geq 0 \\ \mathbf{Q} = \mathbf{Q}^T \geq 0 \\ \mathbf{R} = \mathbf{R}^T > 0 \end{cases} \quad (2.3)$$

Notice that the use of matrix \mathbf{S} is optional; indeed, if the final state \underline{x}_f is imposed then there is no need to insert the expression $\frac{1}{2} (\underline{x}(t_f) - \underline{x}_f)^T \mathbf{S} (\underline{x}(t_f) - \underline{x}_f)$ in the cost to be minimized.

2.2 Positive definite and positive semi-definite matrix

A positive definite matrix \mathbf{M} is denoted $\mathbf{M} > \mathbf{0}$ where $\mathbf{0}$ denotes here the zero matrix. We remind that a real $n \times n$ symmetric matrix $\mathbf{M} = \mathbf{M}^T$ is called positive definite if and only if we have either:

- $\underline{x}^T \mathbf{M} \underline{x} > 0$ for all $\underline{x} \neq 0$;
- All eigenvalues of \mathbf{M} are strictly positive;
- All of the leading principal minors are strictly positive (the leading principal minor of order k is the minor of order k obtained by deleting the last $n - k$ rows and columns);
- \mathbf{M} can be written as $\mathbf{M}_s^T \mathbf{M}_s$ where matrix \mathbf{M}_s is square and invertible.

Similarly a semi-definite positive matrix \mathbf{M} is denoted $\mathbf{M} \geq \mathbf{0}$ where $\mathbf{0}$ denotes here the zero matrix. We remind that a $n \times n$ real symmetric matrix $\mathbf{M} = \mathbf{M}^T$ is called positive semi-definite if and only if we have either:

- $\underline{x}^T \mathbf{M} \underline{x} \geq 0$ for all $\underline{x} \neq 0$;
- All eigenvalues of \mathbf{M} are non-negative;
- All of the principal (not only leading) minors are non-negative (the principal minor of order k is the minor of order k obtained by deleting $n - k$ rows and the $n - k$ columns with the same position than the rows. For instance, in a principal minor where you have deleted rows 1 and 3, you should also delete columns 1 and 3);
- \mathbf{M} can be written as $\mathbf{M}_s^T \mathbf{M}_s$ where matrix \mathbf{M}_s is full row rank.

Furthermore a real symmetric matrix \mathbf{M} is called negative (semi-)definite if $-\mathbf{M}$ is positive (semi-)definite.

Example 2.1. Check that $\mathbf{M}_1 = \mathbf{M}_1^T = \begin{bmatrix} 1 & 2 \\ 2 & 3 \end{bmatrix}$ is not positive definite and that

$\mathbf{M}_2 = \mathbf{M}_2^T = \begin{bmatrix} 1 & -2 \\ -2 & 5 \end{bmatrix}$ is positive definite. ■

2.3 Open loop solution

For this optimal control problem, the Hamiltonian (1.56) reads:

$$H(\underline{x}, \underline{u}, \underline{\lambda}) = \frac{1}{2} (\underline{x}^T(t) \mathbf{Q} \underline{x}(t) + \underline{u}^T(t) \mathbf{R} \underline{u}(t)) + \underline{\lambda}^T(t) (\mathbf{A} \underline{x}(t) + \mathbf{B} \underline{u}(t)) \quad (2.4)$$

The necessary condition for optimality (1.71) yields:

$$\frac{\partial H}{\partial \underline{u}} = \mathbf{R} \underline{u}(t) + \mathbf{B}^T \underline{\lambda}(t) = \underline{0} \quad (2.5)$$

Taking into account that \mathbf{R} is a symmetric matrix, we get:

$$\underline{u}(t) = -\mathbf{R}^{-1} \mathbf{B}^T \underline{\lambda}(t) \quad (2.6)$$

Eliminating $\underline{u}(t)$ in equation (2.1) reads:

$$\begin{cases} \dot{\underline{x}}(t) = \mathbf{A} \underline{x}(t) - \mathbf{B} \mathbf{R}^{-1} \mathbf{B}^T \underline{\lambda}(t) \\ \underline{x}(0) = \underline{x}_0 \end{cases} \quad (2.7)$$

The dynamics of Lagrange multipliers $\underline{\lambda}(t)$ is given by (see (1.62)):

$$\dot{\underline{\lambda}}(t) = -\frac{\partial H}{\partial \underline{x}} = -\mathbf{Q} \underline{x}(t) - \mathbf{A}^T \underline{\lambda}(t) \quad (2.8)$$

The final values of the Lagrange multipliers are given by (1.63). Using the fact that \mathbf{S} is a symmetric matrix we get:

$$\underline{\lambda}(t_f) = \frac{\partial}{\partial \underline{x}(t_f)} \left(\frac{1}{2} (\underline{x}(t_f) - \underline{x}_f)^T \mathbf{S} (\underline{x}(t_f) - \underline{x}_f) \right) = \mathbf{S} (\underline{x}(t_f) - \underline{x}_f) \quad (2.9)$$

Taking into account that matrices \mathbf{Q} and \mathbf{S} are symmetric matrices, equations (2.8) and (2.9) are written as follows:

$$\begin{cases} \dot{\underline{\lambda}}(t) = -\mathbf{Q} \underline{x}(t) - \mathbf{A}^T \underline{\lambda}(t) \\ \underline{\lambda}(t_f) = \mathbf{S} (\underline{x}(t_f) - \underline{x}_f) \end{cases} \quad (2.10)$$

Equations (2.7) and (2.10) represent a two-point boundary value problem. Combining (2.7) and (2.10) into a single state equation yields:

$$\begin{bmatrix} \dot{\underline{x}}(t) \\ \dot{\underline{\lambda}}(t) \end{bmatrix} = \begin{bmatrix} \mathbf{A} & -\mathbf{B} \mathbf{R}^{-1} \mathbf{B}^T \\ -\mathbf{Q} & -\mathbf{A}^T \end{bmatrix} \begin{bmatrix} \underline{x}(t) \\ \underline{\lambda}(t) \end{bmatrix} = \mathbf{H} \begin{bmatrix} \underline{x}(t) \\ \underline{\lambda}(t) \end{bmatrix} \quad (2.11)$$

where we have introduced the Hamiltonian matrix \mathbf{H} defined by:

$$\mathbf{H} = \begin{bmatrix} \mathbf{A} & -\mathbf{B} \mathbf{R}^{-1} \mathbf{B}^T \\ -\mathbf{Q} & -\mathbf{A}^T \end{bmatrix} \quad (2.12)$$

Solving (2.11) yields:

$$\begin{bmatrix} \underline{x}(t) \\ \underline{\lambda}(t) \end{bmatrix} = e^{\mathbf{H}t} \begin{bmatrix} \underline{x}(0) \\ \underline{\lambda}(0) \end{bmatrix} \quad (2.13)$$

When exponential matrix $e^{\mathbf{H}t}$ is partitioned as follows:

$$e^{\mathbf{H}t} = \begin{bmatrix} \mathbf{E}_{11}(t) & \mathbf{E}_{12}(t) \\ \mathbf{E}_{21}(t) & \mathbf{E}_{22}(t) \end{bmatrix} \quad (2.14)$$

Then (2.13) yields:

$$\begin{cases} \underline{x}(t) = \mathbf{E}_{11}(t)\underline{x}(0) + \mathbf{E}_{12}(t)\underline{\lambda}(0) \\ \underline{\lambda}(t) = \mathbf{E}_{21}(t)\underline{x}(0) + \mathbf{E}_{22}(t)\underline{\lambda}(0) \end{cases} \quad (2.15)$$

Then two options are possible: either final state $\underline{x}(t_f)$ is set to \underline{x}_f and the matrix \mathbf{S} is not used in the performance index $J(\underline{u})$ (because it's useless in that case) or final state $\underline{x}(t_f)$ is expected to be close to the final value \underline{x}_f and matrix \mathbf{S} is then used in the performance index $J(\underline{u})$. In both possibilities differential equation (2.11) has to be solved with some constraints on initial and final values, for example on $\underline{x}(0)$ and $\underline{\lambda}(t_f)$: this is a two-point boundary value problem.

- In the case where final state $\underline{x}(t_f)$ is expected to be close to the final value \underline{x}_f then the initial and final conditions turn to be:

$$\begin{cases} \underline{x}(0) = \underline{x}_0 \\ \underline{\lambda}(t_f) = \mathbf{S}(\underline{x}(t_f) - \underline{x}_f) \end{cases} \quad (2.16)$$

Then we have to mix (2.16) and (2.15) at $t = t_f$ to compute the value of $\underline{\lambda}(0)$:

$$\begin{cases} \underline{x}(t) = \mathbf{E}_{11}(t)\underline{x}(0) + \mathbf{E}_{12}(t)\underline{\lambda}(0) \\ \underline{\lambda}(t) = \mathbf{E}_{21}(t)\underline{x}(0) + \mathbf{E}_{22}(t)\underline{\lambda}(0) \\ \underline{\lambda}(t_f) = \mathbf{S}(\underline{x}(t_f) - \underline{x}_f) \end{cases} \Rightarrow \mathbf{E}_{21}(t_f)\underline{x}(0) + \mathbf{E}_{22}(t_f)\underline{\lambda}(0) = \mathbf{S}(\mathbf{E}_{11}(t_f)\underline{x}(0) + \mathbf{E}_{12}(t_f)\underline{\lambda}(0) - \underline{x}_f) \quad (2.17)$$

We finally get the following expression for $\underline{\lambda}(0)$:

$$\underline{\lambda}(0) = (\mathbf{E}_{22}(t_f) - \mathbf{S}\mathbf{E}_{12}(t_f))^{-1} (\mathbf{S}(\mathbf{E}_{11}(t_f)\underline{x}(0) - \underline{x}_f) - \mathbf{E}_{21}(t_f)\underline{x}(0)) \quad (2.18)$$

- In the case where final state $\underline{x}(t_f)$ is imposed to be \underline{x}_f then the initial and final conditions turn to be:

$$\begin{cases} \underline{x}(0) = \underline{x}_0 \\ \underline{x}(t_f) = \underline{x}_f \end{cases} \quad (2.19)$$

Furthermore matrix \mathbf{S} is no more used in the performance index (2.2) to be minimized:

$$J(\underline{u}(t)) = \frac{1}{2} \int_0^{t_f} \underline{x}^T(t)\mathbf{Q}\underline{x}(t) + \underline{u}^T(t)\mathbf{R}\underline{u}(t) dt \quad (2.20)$$

The value of $\underline{\lambda}(0)$ is obtained by solving the first equation of (2.15):

$$\begin{aligned} \underline{x}(t) &= \mathbf{E}_{11}(t)\underline{x}_0 + \mathbf{E}_{12}(t)\underline{\lambda}(0) \\ \Rightarrow \underline{x}_f &= \mathbf{E}_{11}(t_f)\underline{x}_0 + \mathbf{E}_{12}(t_f)\underline{\lambda}(0) \\ \Rightarrow \underline{\lambda}(0) &= (\mathbf{E}_{12}(t_f))^{-1} (\underline{x}_f - \mathbf{E}_{11}(t_f)\underline{x}_0) \end{aligned} \quad (2.21)$$

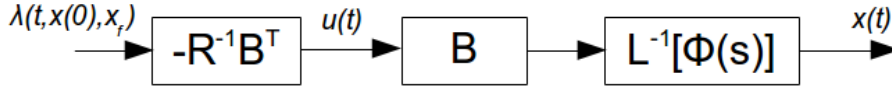

Figure 2.1: Open loop optimal control

It is worth noticing that $\underline{\lambda}(0)$ can be computed through (2.18) as the limit of $\underline{\lambda}(0)$ when $\mathbf{S} \rightarrow \infty$.

Nevertheless, in both situations, the two-point boundary value problem must be solved again if initial conditions change. As a consequence the control $\underline{u}(t)$ is only implementable in an open loop fashion because Lagrange multipliers $\underline{\lambda}(t)$ are not a function of state vector $\underline{x}(t)$ but an explicit function of time t , initial value \underline{x}_0 and final state \underline{x}_f .

From a system point of view, let's take the Laplace transform (denoted \mathcal{L}) of the dynamics of the linear system under consideration:

$$\begin{aligned} \dot{\underline{x}}(t) &= \mathbf{A}\underline{x}(t) + \mathbf{B}\underline{u}(t) \\ \Rightarrow \mathcal{L}[\underline{x}(t)] = \underline{X}(s) &= (sI - \mathbf{A})^{-1} \mathbf{B}\underline{U}(s) \\ &= \mathbf{\Phi}(s)\mathbf{B}\underline{U}(s) \text{ where } \mathbf{\Phi}(s) = (sI - \mathbf{A})^{-1} \end{aligned} \quad (2.22)$$

Then we get the block diagram in Figure 2.1 for the open loop optimal control; In the Figure, $\mathcal{L}^{-1}[\mathbf{\Phi}(s)]$ denotes the inverse Laplace transform of $\mathbf{\Phi}(s)$. It is worth noticing that the Lagrange multiplier $\underline{\lambda}$ depends on time t as well as on the initial value \underline{x}_0 and the final state \underline{x}_f : this is why it is denoted $\underline{\lambda}(t, \underline{x}_0, \underline{x}_f)$.

2.4 Application to minimum energy control problem

Minimum energy control problem appears when $\mathbf{Q} := \mathbf{0}$.

2.4.1 Moving a linear system close to a final state with minimum energy

Let's consider the following dynamical system:

$$\dot{\underline{x}}(t) = \mathbf{A}\underline{x}(t) + \mathbf{B}\underline{u}(t) \quad (2.23)$$

We are looking for the control $\underline{u}(t)$ which moves the system from the initial state $\underline{x}(0) = \underline{x}_0$ to a final state which should be close to a given value $\underline{x}(t_f) = \underline{x}_f$ at final time $t = t_f$. We will assume that the performance index to be minimized is the following quadratic performance index where \mathbf{R} is a symmetric positive definite matrix:

$$J(\underline{u}(t)) = \frac{1}{2} (\underline{x}(t_f) - \underline{x}_f)^T \mathbf{S} (\underline{x}(t_f) - \underline{x}_f) + \frac{1}{2} \int_0^{t_f} \underline{u}^T(t) \mathbf{R} \underline{u}(t) dt \quad (2.24)$$

For this optimal control problem, the Hamiltonian (2.4) is:

$$H(\underline{x}, \underline{u}, \underline{\lambda}) = \frac{1}{2} \underline{u}^T(t) \mathbf{R} \underline{u}(t) + \underline{\lambda}^T(t) (\mathbf{A} \underline{x}(t) + \mathbf{B} \underline{u}(t)) \quad (2.25)$$

The necessary condition for optimality (2.5) yields:

$$\frac{\partial H}{\partial \underline{u}} = \mathbf{R} \underline{u}(t) + \mathbf{B}^T \underline{\lambda}(t) = 0 \quad (2.26)$$

We get:

$$\underline{u}(t) = -\mathbf{R}^{-1} \mathbf{B}^T \underline{\lambda}(t) \quad (2.27)$$

Eliminating $\underline{u}(t)$ in equation (2.24) reads:

$$\dot{\underline{x}}(t) = \mathbf{A} \underline{x}(t) - \mathbf{B} \mathbf{R}^{-1} \mathbf{B}^T \underline{\lambda}(t) \quad (2.28)$$

The dynamics of Lagrange multipliers $\underline{\lambda}(t)$ is given by (2.8):

$$\dot{\underline{\lambda}}(t) = -\frac{\partial H}{\partial \underline{x}} = -\mathbf{A}^T \underline{\lambda}(t) \quad (2.29)$$

We get from the preceding equation:

$$\underline{\lambda}(t) = e^{-\mathbf{A}^T t} \underline{\lambda}(0) \quad (2.30)$$

The value of $\underline{\lambda}(0)$ will influence the final value of the state vector $\underline{x}(t)$. Indeed let's integrate the linear differential equation:

$$\dot{\underline{x}}(t) = \mathbf{A} \underline{x}(t) - \mathbf{B} \mathbf{R}^{-1} \mathbf{B}^T \underline{\lambda}(t) = \mathbf{A} \underline{x}(t) + \mathbf{B} \mathbf{R}^{-1} \mathbf{B}^T e^{-\mathbf{A}^T t} \underline{\lambda}(0) \quad (2.31)$$

This leads to the following expression of the state vector $\underline{x}(t)$:

$$\begin{aligned} \underline{x}(t) &= e^{\mathbf{A}t} \underline{x}_0 + e^{\mathbf{A}t} \int_0^t e^{-\mathbf{A}\tau} \mathbf{B} \mathbf{R}^{-1} \mathbf{B}^T e^{-\mathbf{A}^T \tau} \underline{\lambda}(0) d\tau \\ &= e^{\mathbf{A}t} \underline{x}_0 + e^{\mathbf{A}t} \left(\int_0^t e^{-\mathbf{A}\tau} \mathbf{B} \mathbf{R}^{-1} \mathbf{B}^T e^{-\mathbf{A}^T \tau} d\tau \right) \underline{\lambda}(0) \end{aligned} \quad (2.32)$$

Or:

$$\underline{x}(t) = e^{\mathbf{A}t} \underline{x}_0 + e^{\mathbf{A}t} \mathbf{W}_c(t) \underline{\lambda}(0) \quad (2.33)$$

where matrix $\mathbf{W}_c(t)$ is defined as follows:

$$\mathbf{W}_c(t) = \int_0^t e^{-\mathbf{A}\tau} \mathbf{B} \mathbf{R}^{-1} \mathbf{B}^T e^{-\mathbf{A}^T \tau} d\tau \quad (2.34)$$

Now using (2.16) we set $\underline{\lambda}(t_f)$ as follows:

$$\underline{\lambda}(t_f) = \mathbf{S} (\underline{x}(t_f) - \underline{x}_f) \quad (2.35)$$

Using (2.30) and (2.33) we get:

$$\begin{cases} \underline{\lambda}(t_f) = e^{-\mathbf{A}^T t_f} \underline{\lambda}(0) \\ \underline{x}(t_f) = e^{\mathbf{A}t_f} \underline{x}_0 + e^{\mathbf{A}t_f} \mathbf{W}_c(t_f) \underline{\lambda}(0) \end{cases} \quad (2.36)$$

And the transversality condition (2.35) is rewritten as follows:

$$\begin{aligned}\underline{\lambda}(t_f) &= \mathbf{S} (\underline{x}(t_f) - \underline{x}_f) \\ \Leftrightarrow e^{-\mathbf{A}^T t_f} \underline{\lambda}(0) &= \mathbf{S} (e^{\mathbf{A} t_f} \underline{x}_0 + e^{\mathbf{A} t_f} \mathbf{W}_c(t_f) \underline{\lambda}(0) - \underline{x}_f)\end{aligned}\quad (2.37)$$

Solving the preceding linear equation in $\underline{\lambda}(0)$ gives the following expression:

$$\begin{aligned}\left(e^{-\mathbf{A}^T t_f} - \mathbf{S} e^{\mathbf{A} t_f} \mathbf{W}_c(t_f) \right) \underline{\lambda}(0) &= \mathbf{S} (e^{\mathbf{A} t_f} \underline{x}_0 - \underline{x}_f) \\ \Leftrightarrow \underline{\lambda}(0) &= \left(e^{-\mathbf{A}^T t_f} - \mathbf{S} e^{\mathbf{A} t_f} \mathbf{W}_c(t_f) \right)^{-1} \mathbf{S} (e^{\mathbf{A} t_f} \underline{x}_0 - \underline{x}_f)\end{aligned}\quad (2.38)$$

Using the expression of $\underline{\lambda}(0)$ in (2.30) leads to the expression of the Lagrange multiplier $\underline{\lambda}(t)$:

$$\underline{\lambda}(t) = e^{-\mathbf{A}^T t} \left(e^{-\mathbf{A}^T t_f} - \mathbf{S} e^{\mathbf{A} t_f} \mathbf{W}_c(t_f) \right)^{-1} \mathbf{S} (e^{\mathbf{A} t_f} \underline{x}_0 - \underline{x}_f) \quad (2.39)$$

Finally control $\underline{u}(t)$ is obtained thanks equation (2.27):

$$\underline{u}(t) = -\mathbf{R}^{-1} \mathbf{B}^T \underline{\lambda}(t) \quad (2.40)$$

It is clear from the expression of $\underline{\lambda}(t)$ that the control $\underline{u}(t)$ explicitly depends on the initial state \underline{x}_0 .

2.4.2 Moving a linear system exactly to a final state with minimum energy

We are now looking for the control $\underline{u}(t)$ which moves the system from the initial state $\underline{x}(0) = \underline{x}_0$ to a given final state $\underline{x}(t_f) = \underline{x}_f$ at final time $t = t_f$. We will assume that the performance index to be minimized is the following quadratic performance index where \mathbf{R} is a symmetric positive definite matrix:

$$J = \frac{1}{2} \int_0^{t_f} \underline{u}^T(t) \mathbf{R} \underline{u}(t) dt \quad (2.41)$$

To solve this problem the same reasoning applies than in the previous example. As far as control $\underline{u}(t)$ is concerned this leads to equation (2.27). The change is that now the final value of the state vector $\underline{x}(t)$ is imposed to be $\underline{x}(t_f) = \underline{x}_f$. So there is no final value for the Lagrange multipliers. Indeed $\underline{\lambda}(t_f)$, or equivalently $\underline{\lambda}(0)$, has to be set such that $\underline{x}(t_f) = \underline{x}_f$. We have seen in (2.33) that the state vector $\underline{x}(t)$ has the following expression:

$$\underline{x}(t) = e^{\mathbf{A} t} \underline{x}_0 + e^{\mathbf{A} t} \mathbf{W}_c(t) \underline{\lambda}(0) \quad (2.42)$$

where matrix $\mathbf{W}_c(t)$ is defined as follows:

$$\mathbf{W}_c(t) = \int_0^t e^{-\mathbf{A} \tau} \mathbf{B} \mathbf{R}^{-1} \mathbf{B}^T e^{-\mathbf{A}^T \tau} d\tau \quad (2.43)$$

Then we set $\underline{\lambda}(0)$ as follows where \underline{c}_0 is a constant vector:

$$\underline{\lambda}(0) = \mathbf{W}_c^{-1}(t_f) \underline{c}_0 \quad (2.44)$$

We get:

$$\underline{x}(t) = e^{\mathbf{A}t} \underline{x}_0 + e^{\mathbf{A}t} \mathbf{W}_c(t) \mathbf{W}_c^{-1}(t_f) \underline{c}_0 \quad (2.45)$$

Constant vector \underline{c}_0 is used to satisfy the final value on the state vector $\underline{x}(t)$. Setting $\underline{x}(t_f) = \underline{x}_f$ leads to the value of constant vector \underline{c}_0 :

$$\underline{x}(t_f) = \underline{x}_f \Rightarrow \underline{c}_0 = e^{-\mathbf{A}t_f} \underline{x}_f - \underline{x}_0 \quad (2.46)$$

Thus:

$$\underline{\lambda}(0) = \mathbf{W}_c^{-1}(t_f) (e^{-\mathbf{A}t_f} \underline{x}_f - \underline{x}_0) \quad (2.47)$$

Using (2.47) in (2.30) leads to the expression of the Lagrange multiplier $\underline{\lambda}(t)$:

$$\begin{aligned} \underline{\lambda}(t) &= e^{-\mathbf{A}^T t} \underline{\lambda}(0) \\ &= e^{-\mathbf{A}^T t} \mathbf{W}_c^{-1}(t_f) (e^{-\mathbf{A}t_f} \underline{x}_f - \underline{x}_0) \end{aligned} \quad (2.48)$$

Finally the control $\underline{u}(t)$ which moves with the minimum energy the system from the initial state $\underline{x}(0) = \underline{x}_0$ to a given final state $\underline{x}(t_f) = \underline{x}_f$ at final time $t = t_f$ has the following expression:

$$\begin{aligned} \underline{u}(t) &= -\mathbf{R}^{-1} \mathbf{B}^T \underline{\lambda}(t) \\ &= -\mathbf{R}^{-1} \mathbf{B}^T e^{-\mathbf{A}^T t} \underline{\lambda}(0) \\ &= -\mathbf{R}^{-1} \mathbf{B}^T e^{-\mathbf{A}^T t} \mathbf{W}_c^{-1}(t_f) (e^{-\mathbf{A}t_f} \underline{x}_f - \underline{x}_0) \end{aligned} \quad (2.49)$$

It is clear from the preceding expression that the control $\underline{u}(t)$ explicitly depends on the initial state \underline{x}_0 . When comparing the initial value $\underline{\lambda}(0)$ of the Lagrange multiplier obtained in (2.47) in the case where the final state is imposed to be $\underline{x}(t_f) = \underline{x}_f$ with the expression of the initial value of the Lagrange multiplier obtained in (2.38) in the case where the final state $\underline{x}(t_f)$ is close to a given final state \underline{x}_f we can see that the expression in (2.47) corresponds to the limit of the initial value (2.38) when matrix \mathbf{S} moves towards infinity (note that $(e^{\mathbf{A}t_f})^{-1} = e^{-\mathbf{A}t_f}$):

$$\begin{aligned} \lim_{\mathbf{S} \rightarrow \infty} & \left(e^{-\mathbf{A}^T t_f} - \mathbf{S} e^{\mathbf{A}t_f} \mathbf{W}_c(t_f) \right)^{-1} \mathbf{S} (e^{\mathbf{A}t_f} \underline{x}_0 - \underline{x}_f) \\ &= \lim_{\mathbf{S} \rightarrow \infty} \left(-\mathbf{S} e^{\mathbf{A}t_f} \mathbf{W}_c(t_f) \right)^{-1} \mathbf{S} (e^{\mathbf{A}t_f} \underline{x}_0 - \underline{x}_f) \\ &= \lim_{\mathbf{S} \rightarrow \infty} \mathbf{W}_c^{-1}(t_f) e^{-\mathbf{A}t_f} \mathbf{S}^{-1} \mathbf{S} (e^{\mathbf{A}t_f} \underline{x}_0 - \underline{x}_f) \\ &= \mathbf{W}_c^{-1}(t_f) e^{-\mathbf{A}t_f} (e^{\mathbf{A}t_f} \underline{x}_0 - \underline{x}_f) \end{aligned} \quad (2.50)$$

2.4.3 Example

Given the following scalar plant:

$$\begin{cases} \dot{x}(t) = ax(t) + bu(t) \\ x(0) = x_0 \end{cases} \quad (2.51)$$

Find the optimal control for the following cost functional and final states constraints:

We wish to compute a finite horizon Linear Quadratic Regulator with either a fixed or a weighted final state x_f .

- When the final state $x(t_f)$ is set to a fixed value x_f and the cost functional is set to:

$$J = \frac{1}{2} \int_0^{t_f} \rho u^2(t) dt \quad (2.52)$$

- When the final state $x(t_f)$ shall be close of a fixed value x_f so that the cost functional is modified as follows where is a positive scalar ($\mathbf{S} > 0$):

$$J = \frac{1}{2} (x(t_f) - x_f)^T \mathbf{S} (x(t_f) - x_f) + \frac{1}{2} \int_0^{t_f} \rho u^2(t) dt \quad (2.53)$$

In both cases the two-point boundary value problem which shall be solved depends on the solution of the following differential equation where Hamiltonian matrix \mathbf{H} appears:

$$\begin{bmatrix} \dot{x}(t) \\ \dot{\lambda}(t) \end{bmatrix} = \begin{bmatrix} \mathbf{A} & -\mathbf{B}\mathbf{R}^{-1}\mathbf{B}^T \\ -\mathbf{Q} & -\mathbf{A}^T \end{bmatrix} \begin{bmatrix} x(t) \\ \lambda(t) \end{bmatrix} = \begin{bmatrix} a & -b^2/\rho \\ 0 & -a \end{bmatrix} \begin{bmatrix} x(t) \\ \lambda(t) \end{bmatrix} = \mathbf{H} \begin{bmatrix} x(t) \\ \lambda(t) \end{bmatrix} \quad (2.54)$$

The solution of this differential equation reads:

$$\begin{bmatrix} x(t) \\ \lambda(t) \end{bmatrix} = e^{\mathbf{H}t} \begin{bmatrix} x(0) \\ \lambda(0) \end{bmatrix} \quad (2.55)$$

Denoting by s the Laplace variable, the exponential of matrix $\mathbf{H}t$ is obtained thanks to the inverse of the Laplace transform denoted \mathcal{L}^{-1} :

$$\begin{aligned} e^{\mathbf{H}t} &= \mathcal{L}^{-1} \left((s\mathbb{I} - \mathbf{H})^{-1} \right) \\ &= \mathcal{L}^{-1} \left(\begin{bmatrix} s-a & b^2/\rho \\ 0 & s+a \end{bmatrix}^{-1} \right) \\ &= \mathcal{L}^{-1} \left(\frac{1}{(s-a)(s+a)} \begin{bmatrix} s+a & -b^2/\rho \\ 0 & s-a \end{bmatrix} \right) \\ &= \mathcal{L}^{-1} \left(\begin{bmatrix} \frac{1}{s-a} & \frac{-b^2}{\rho(s^2-a^2)} \\ 0 & \frac{1}{s+a} \end{bmatrix} \right) \\ \Leftrightarrow e^{\mathbf{H}t} &= \begin{bmatrix} e^{at} & \frac{-b^2(e^{at}-e^{-at})}{2\rho a} \\ 0 & e^{-at} \end{bmatrix} \end{aligned} \quad (2.56)$$

That is:

$$\begin{bmatrix} x(t) \\ \lambda(t) \end{bmatrix} = e^{\mathbf{H}t} \begin{bmatrix} x(0) \\ \lambda(0) \end{bmatrix} = \begin{bmatrix} e^{at} & \frac{-b^2(e^{at}-e^{-at})}{2\rho a} \\ 0 & e^{-at} \end{bmatrix} \begin{bmatrix} x(0) \\ \lambda(0) \end{bmatrix} \quad (2.57)$$

- If the final state $x(t_f)$ is set to the value x_f then the value $\lambda(0)$ is obtained by solving the first equation of (2.57):

$$\begin{aligned} x(t_f) = x_f &= e^{at_f} x(0) - \frac{b^2(e^{at_f}-e^{-at_f})}{2\rho a} \lambda(0) \\ \Rightarrow \lambda(0) &= \frac{-2\rho a}{b^2(e^{at_f}-e^{-at_f})} (x_f - e^{at_f} x(0)) \end{aligned} \quad (2.58)$$

And:

$$\begin{cases} x(t) &= e^{at}x(0) + \frac{e^{at}-e^{-at}}{e^{at_f}-e^{-at_f}}(x_f - e^{at_f}x(0)) \\ \lambda(t) &= e^{-at}\lambda(0) = \frac{-2\rho ae^{-at}}{b^2(e^{at_f}-e^{-at_f})}(x_f - e^{at_f}x(0)) \end{cases} \quad (2.59)$$

The optimal control $u(t)$ is given by:

$$u(t) = -\mathbf{R}^{-1}\mathbf{B}^T\lambda(t) = \frac{-b}{\rho}\lambda(t) = \frac{2ae^{-at}}{b(e^{at_f}-e^{-at_f})}(x_f - e^{at_f}x(0)) \quad (2.60)$$

Interestingly enough, the open loop control is independent of the control weighting ρ .

- If the final state $x(t_f)$ is expected to be close to the final value x_f then we have to mix the two equations of (2.57) and the constraint $\lambda(t_f) = \mathbf{S}(x(t_f) - x_f)$ to compute the value of $\lambda(0)$:

$$\begin{aligned} \lambda(t_f) &= \mathbf{S}(x(t_f) - x_f) \\ \Rightarrow e^{-at_f}\lambda(0) &= \mathbf{S}\left(e^{at_f}x(0) - \frac{b^2(e^{at_f}-e^{-at_f})}{2\rho a}\lambda(0) - x_f\right) \\ \Leftrightarrow \lambda(0) &= \frac{\mathbf{S}(e^{at_f}x(0)-x_f)}{e^{-at_f} + \frac{\mathbf{S}b^2(e^{at_f}-e^{-at_f})}{2\rho a}} \end{aligned} \quad (2.61)$$

Obviously, when $\mathbf{S} \rightarrow \infty$ we obtain for $\lambda(0)$ the same expression than (2.58).

2.5 Closed loop solution - Riccati differential equation

The closed loop solution involves the state vector $\underline{x}(t)$ within the expression of the optimal control $\underline{u}(t)$. In order to achieve a closed loop solution we will assume in the following that the state vector $\underline{x}(t)$ shall move towards the null value:

$$\underline{x}_f = \underline{0} \quad (2.62)$$

Indeed, $\underline{x}_f = \underline{0}$ corresponds to the single equilibrium point for a linear system.

2.5.1 Final state close to zero

We will use matrix \mathbf{S} to weight the final state in the performance index (2.2) but we will not set the final state $\underline{x}(t_f)$ which is assumed to be free.

The cost to be minimized reads:

$$J(\underline{u}(t)) = \frac{1}{2}\underline{x}^T(t_f)\mathbf{S}\underline{x}(t_f) + \frac{1}{2}\int_0^{t_f}\underline{x}^T(t)\mathbf{Q}\underline{x}(t) + \underline{u}^T(t)\mathbf{R}\underline{u}(t) dt \quad (2.63)$$

We have seen in (2.15) that the solution of this optimal control problem reads:

$$\begin{cases} \underline{x}(t) = \mathbf{E}_{11}(t)\underline{x}(0) + \mathbf{E}_{12}(t)\underline{\lambda}(0) \\ \underline{\lambda}(t) = \mathbf{E}_{21}(t)\underline{x}(0) + \mathbf{E}_{22}(t)\underline{\lambda}(0) \end{cases} \quad (2.64)$$

where:

$$\begin{cases} e^{\mathbf{H}t} = \begin{bmatrix} \mathbf{E}_{11}(t) & \mathbf{E}_{12}(t) \\ \mathbf{E}_{21}(t) & \mathbf{E}_{22}(t) \end{bmatrix} \\ \mathbf{H} = \begin{bmatrix} \mathbf{A} & -\mathbf{B}\mathbf{R}^{-1}\mathbf{B}^T \\ -\mathbf{Q} & -\mathbf{A}^T \end{bmatrix} \end{cases} \quad (2.65)$$

The expression of $\underline{\lambda}(0)$ is obtained from (2.18) where we set $\underline{x}_f = \underline{0}$. We get the following expression where $\underline{x}(0)$ can now be factorized:

$$\begin{aligned} \underline{\lambda}(0) &= (\mathbf{E}_{22}(t_f) - \mathbf{S}\mathbf{E}_{12}(t_f))^{-1} (\mathbf{S}(\mathbf{E}_{11}(t_f)\underline{x}(0) - \underline{x}_f) - \mathbf{E}_{21}(t_f)\underline{x}(0)) \Big|_{\underline{x}_f=\underline{0}} \\ &= (\mathbf{E}_{22}(t_f) - \mathbf{S}\mathbf{E}_{12}(t_f))^{-1} (\mathbf{S}\mathbf{E}_{11}(t_f)\underline{x}(0) - \mathbf{E}_{21}(t_f)\underline{x}(0)) \\ &= (\mathbf{E}_{22}(t_f) - \mathbf{S}\mathbf{E}_{12}(t_f))^{-1} (\mathbf{S}\mathbf{E}_{11}(t_f) - \mathbf{E}_{21}(t_f)) \underline{x}(0) \end{aligned} \quad (2.66)$$

Thus, from the second equation of (2.64) $\underline{\lambda}(t)$ reads as follows where $\underline{x}(0)$ can again be factorized::

$$\begin{aligned} \underline{\lambda}(t) &= \mathbf{E}_{21}(t)\underline{x}(0) + \mathbf{E}_{22}(t)\underline{\lambda}(0) \\ &= \left(\mathbf{E}_{21}(t) + \mathbf{E}_{22}(t) (\mathbf{E}_{22}(t_f) - \mathbf{S}\mathbf{E}_{12}(t_f))^{-1} (\mathbf{S}\mathbf{E}_{11}(t_f) - \mathbf{E}_{21}(t_f)) \right) \underline{x}(0) \end{aligned} \quad (2.67)$$

That is:

$$\underline{\lambda}(t) = \mathbf{X}_2(t)\underline{x}(0) \quad (2.68)$$

where

$$\mathbf{X}_2(t) = \mathbf{E}_{21}(t) + \mathbf{E}_{22}(t) (\mathbf{E}_{22}(t_f) - \mathbf{S}\mathbf{E}_{12}(t_f))^{-1} (\mathbf{S}\mathbf{E}_{11}(t_f) - \mathbf{E}_{21}(t_f)) \quad (2.69)$$

In addition, using the expression of $\underline{\lambda}(0)$ in the first equation of (2.64) we can compute $\underline{x}(0)$ as a function of $\underline{x}(t)$:

$$\begin{aligned} \underline{x}(t) &= \mathbf{E}_{11}(t)\underline{x}(0) + \mathbf{E}_{12}(t)\underline{\lambda}(0) \\ &= \left(\mathbf{E}_{11}(t) + \mathbf{E}_{12}(t) (\mathbf{E}_{22}(t_f) - \mathbf{S}\mathbf{E}_{12}(t_f))^{-1} (\mathbf{S}\mathbf{E}_{11}(t_f) - \mathbf{E}_{21}(t_f)) \right) \underline{x}(0) \end{aligned} \quad (2.70)$$

That is:

$$\underline{x}(t) = \mathbf{X}_1(t)\underline{x}(0) \quad (2.71)$$

where

$$\mathbf{X}_1(t) = \mathbf{E}_{11}(t) + \mathbf{E}_{12}(t) (\mathbf{E}_{22}(t_f) - \mathbf{S}\mathbf{E}_{12}(t_f))^{-1} (\mathbf{S}\mathbf{E}_{11}(t_f) - \mathbf{E}_{21}(t_f)) \quad (2.72)$$

Combining (2.68) and (2.71) shows that when $\underline{x}_f = \underline{0}$ then Lagrange multipliers $\underline{\lambda}(t)$ linearly depends on the state vector $\underline{x}(t)$:

$$\underline{\lambda}(t) = \mathbf{X}_2(t)\mathbf{X}_1^{-1}(t)\underline{x}(t) \quad (2.73)$$

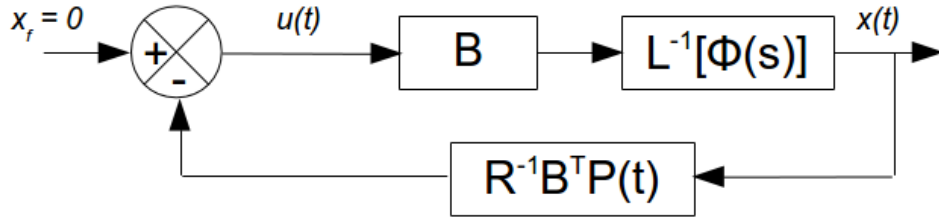

Figure 2.2: Closed loop optimal control ($\mathcal{L}^{-1}[\Phi(s)]$ denotes the inverse Laplace transform of $\Phi(s)$)

Then the Lagrange multipliers $\underline{\lambda}(t)$ can be expressed as follows, where $\mathbf{P}(t)$ is a $n \times n$ symmetric matrix:

$$\begin{cases} \underline{\lambda}(t) = \mathbf{P}(t)\underline{x}(t) \\ \mathbf{P}(t) = \mathbf{X}_2(t)\mathbf{X}_1^{-1}(t) \end{cases} \quad (2.74)$$

Once matrix $\mathbf{P}(t)$ is computed (analytically or numerically), the optimal control $\underline{u}(t)$ which minimizes (2.2) is given by (2.6) and (2.74):

$$\underline{u}(t) = -\mathbf{K}(t)\underline{x}(t) \quad (2.75)$$

where $\mathbf{K}(t)$ is the optimal state feedback gain matrix:

$$\mathbf{K}(t) = \mathbf{R}^{-1}\mathbf{B}^T\mathbf{P}(t) \quad (2.76)$$

It can be seen that the optimal control is a state feedback law. Indeed, because the matrix $\mathbf{P}(t)$ does not depend on the system states, the feedback gain $\mathbf{K}(t)$ is optimal for all initial conditions $\underline{x}(0)$ on the state vector $\underline{x}(t)$.

From a system point of view, let's take the Laplace transform (denoted \mathcal{L}) of the dynamics of the linear system under consideration:

$$\begin{aligned} \dot{\underline{x}}(t) &= \mathbf{A}\underline{x}(t) + \mathbf{B}\underline{u}(t) \\ \Rightarrow \mathcal{L}[\underline{x}(t)] = \underline{X}(s) &= (sI - \mathbf{A})^{-1}\mathbf{B}\underline{U}(s) \\ &= \Phi(s)\mathbf{B}\underline{U}(s) \text{ where } \Phi(s) = (sI - \mathbf{A})^{-1} \end{aligned} \quad (2.77)$$

Then we get the block diagram in Figure 2.2 for the closed-loop optimal control: note that $\underline{x}_f = 0$ corresponds to the regulator problem. The tracker problem where $\underline{x}_f \neq 0$ will be tackled in a following chapter. In addition it is worth noticing that compared to Figure 2.1 the Lagrange multipliers $\underline{\lambda}$ no more appears in the optimal control loop in Figure 2.2. Indeed, it has been replaced by matrix $\mathbf{P}(t)$ which enables to provide a closed loop solution whatever the initial conditions on state vector $\underline{x}(t)$.

2.5.2 Riccati differential equation

Using (2.8) and (2.9), we can compute the time derivative of the Lagrange multipliers $\underline{\lambda}(t) = \mathbf{P}(t)\underline{x}(t)$ as follows:

$$\begin{cases} \dot{\underline{\lambda}}(t) = \dot{\mathbf{P}}(t)\underline{x}(t) + \mathbf{P}(t)\dot{\underline{x}}(t) = -\mathbf{Q}\underline{x}(t) - \mathbf{A}^T\underline{\lambda}(t) \\ \underline{\lambda}(t_f) = \mathbf{P}(t_f)\underline{x}(t_f) = \mathbf{S}\underline{x}(t_f) \end{cases} \quad (2.78)$$

Then, substituting (2.1), (2.6) and (2.74) within (2.78) we get:

$$\Rightarrow \begin{cases} \dot{\underline{x}} = \mathbf{A}\underline{x}(t) + \mathbf{B}\underline{u}(t) \\ \underline{u}(t) = -\mathbf{R}^{-1}\mathbf{B}^T\lambda(t) \\ \lambda(t) = \mathbf{P}(t)\underline{x}(t) \end{cases} \Rightarrow \begin{cases} \dot{\mathbf{P}}(t)\underline{x}(t) + \mathbf{P}(t) (\mathbf{A}\underline{x}(t) - \mathbf{B}\mathbf{R}^{-1}\mathbf{B}^T\mathbf{P}(t)\underline{x}(t)) = -\mathbf{Q}\underline{x}(t) - \mathbf{A}^T\mathbf{P}(t)\underline{x}(t) \\ \mathbf{P}(t_f)\underline{x}(t_f) = \mathbf{S}\underline{x}(t_f) \end{cases} \quad (2.79)$$

Because the previous equation is true for all $\underline{x}(t)$ and $\underline{x}(t_f)$ we obtain the following equation, which is known as the *Riccati differential equation*:

$$\begin{cases} -\dot{\mathbf{P}}(t) = \mathbf{A}^T\mathbf{P}(t) + \mathbf{P}(t)\mathbf{A} - \mathbf{P}(t)\mathbf{B}\mathbf{R}^{-1}\mathbf{B}^T\mathbf{P}(t) + \mathbf{Q} \\ \mathbf{P}(t_f) = \mathbf{S} \end{cases} \quad (2.80)$$

From a computational point of view, the *Riccati differential equation* (2.80) is integrated backward. The kernel $\mathbf{P}(t)$ is stored for each values of t and then is used to compute $\mathbf{K}(t)$ and $\underline{u}(t)$.

2.5.3 Final state set to zero

When the final state $\underline{x}(t_f)$ is imposed to be exactly $\underline{x}_f = 0$ the cost to be minimized reads:

$$J(\underline{u}(t)) = \frac{1}{2} \int_0^{t_f} \underline{x}^T(t)\mathbf{Q}\underline{x}(t) + \underline{u}^T(t)\mathbf{R}\underline{u}(t) dt \quad (2.81)$$

We have seen in (2.73) that $\lambda(t)$ has the following expression:

$$\lambda(t) = \mathbf{X}_2(t)\mathbf{X}_1^{-1}(t)\underline{x}(t) \quad (2.82)$$

Square matrices $\mathbf{X}_1(t)$ and $\mathbf{X}_2(t)$ can be computed through relationships (2.72) and (2.69) by taking the limit when $\mathbf{S} \rightarrow \infty$:

$$\begin{aligned} \mathbf{X}_1(t) &= \lim_{\mathbf{S} \rightarrow \infty} \mathbf{E}_{11}(t) + \mathbf{E}_{12}(t) (\mathbf{E}_{22}(t_f) - \mathbf{S}\mathbf{E}_{12}(t_f))^{-1} (\mathbf{S}\mathbf{E}_{11}(t_f) - \mathbf{E}_{21}(t_f)) \\ &= \lim_{\mathbf{S} \rightarrow \infty} \mathbf{E}_{11}(t) - \mathbf{E}_{12}(t)\mathbf{E}_{12}^{-1}(t_f)\mathbf{S}^{-1}\mathbf{S}\mathbf{E}_{11}(t_f) \\ &= \mathbf{E}_{11}(t) - \mathbf{E}_{12}(t)\mathbf{E}_{12}^{-1}(t_f)\mathbf{E}_{11}(t_f) \\ \mathbf{X}_2(t) &= \lim_{\mathbf{S} \rightarrow \infty} \mathbf{E}_{21}(t) + \mathbf{E}_{22}(t) (\mathbf{E}_{22}(t_f) - \mathbf{S}\mathbf{E}_{12}(t_f))^{-1} (\mathbf{S}\mathbf{E}_{11}(t_f) - \mathbf{E}_{21}(t_f)) \\ &= \lim_{\mathbf{S} \rightarrow \infty} \mathbf{E}_{21}(t) - \mathbf{E}_{22}(t)\mathbf{E}_{12}^{-1}(t_f)\mathbf{S}^{-1}\mathbf{S}\mathbf{E}_{11}(t_f) \\ &= \mathbf{E}_{21}(t) - \mathbf{E}_{22}(t)\mathbf{E}_{12}^{-1}(t_f)\mathbf{E}_{11}(t_f) \end{aligned} \quad (2.83)$$

As far as $\begin{bmatrix} \mathbf{E}_{11}(0) & \mathbf{E}_{12}(0) \\ \mathbf{E}_{21}(0) & \mathbf{E}_{22}(0) \end{bmatrix} := e^{\mathbf{H}t}|_{t=0} = e^{\mathbf{0}} = \mathbb{I}$, where \mathbb{I} is the $2n \times 2n$ identity matrix, we have:

$$\begin{cases} \mathbf{E}_{11}(0) = \mathbf{E}_{22}(0) = \mathbb{I} \\ \mathbf{E}_{12}(0) = \mathbf{E}_{21}(0) = \mathbf{0} \end{cases} \Rightarrow \begin{cases} \mathbf{X}_1(0) = \mathbb{I} \\ \mathbf{X}_2(0) = -\mathbf{E}_{12}^{-1}(t_f)\mathbf{E}_{11}(t_f) \end{cases} \quad (2.84)$$

Consequently we get for $\mathbf{P}(0)$ and $\lambda(0)$ the following expressions:

$$\begin{cases} \mathbf{P}(0) = \mathbf{X}_2(0)\mathbf{X}_1^{-1}(0) = -\mathbf{E}_{12}^{-1}(t_f)\mathbf{E}_{11}(t_f) \\ \lambda(0) = \mathbf{P}(0)\underline{x}(0) = -\mathbf{E}_{12}^{-1}(t_f)\mathbf{E}_{11}(t_f)\underline{x}(0) \end{cases} \quad (2.85)$$

Furthermore, the *Riccati differential equation* (2.80) to get $\mathbf{P}(t)$ now reads:

$$\begin{cases} -\dot{\mathbf{P}}(t) = \mathbf{A}^T \mathbf{P}(t) + \mathbf{P}(t) \mathbf{A} - \mathbf{P}(t) \mathbf{B} \mathbf{R}^{-1} \mathbf{B}^T \mathbf{P}(t) + \mathbf{Q} \\ \mathbf{P}(0) = -\mathbf{E}_{12}^{-1}(t_f) \mathbf{E}_{11}(t_f) \end{cases} \quad (2.86)$$

Now let's compute $\mathbf{P}(t_f)$. From (2.83) we get:

$$\begin{aligned} \mathbf{X}_1(t_f) &= \mathbf{E}_{11}(t_f) - \mathbf{E}_{12}(t_f) \mathbf{E}_{12}^{-1}(t_f) \mathbf{E}_{11}(t_f) = \mathbf{0} \\ \mathbf{X}_2(t_f) &= \mathbf{E}_{21}(t_f) - \mathbf{E}_{22}(t_f) \mathbf{E}_{12}^{-1}(t_f) \mathbf{E}_{11}(t_f) \end{aligned} \quad (2.87)$$

Consequently $\mathbf{P}(t_f) = \mathbf{X}_2(t_f) \mathbf{X}_1^{-1}(t_f) \rightarrow \infty$ because $\mathbf{X}_1(t_f) = \mathbf{0}$ when the final value $\underline{x}(t_f)$ is set to zero. This is in line with the final value of $\mathbf{P}(t)$, $\mathbf{P}(t_f) = \mathbf{S}$, as indicated by Equation (2.80). Indeed, when the final value $\underline{x}(t_f)$ is imposed, then $\mathbf{S} \rightarrow \infty$ and consequently $\mathbf{P}(t_f) \rightarrow \infty$ when the final value $\underline{x}(t_f)$ is set to zero. To avoid the numerical difficulty when $t = t_f$ we shall set $\underline{u}(t_f) = \underline{0}$. Thus the optimal control reads:

$$\underline{u}(t) = \begin{cases} -\mathbf{K}(t) \underline{x}(t) & \forall 0 \leq t < t_f \\ \underline{0} & \text{for } t = t_f \end{cases} \quad (2.88)$$

Where:

$$\mathbf{K}(t) = \mathbf{R}^{-1} \mathbf{B}^T \mathbf{P}(t) \quad (2.89)$$

Besides it is worth noticing that when the final state is set to zero there is no need to solve the Riccati differential equation (2.86). Indeed, when the final state $\underline{x}(t_f)$ is imposed to be exactly $\underline{x}(t_f) = \underline{x}_f := \underline{0}$, then equation (2.13) can be rewritten as follows where t is shifted to $t - t_f$:

$$\begin{aligned} \Leftrightarrow \begin{bmatrix} \underline{x}(t) \\ \underline{\lambda}(t) \end{bmatrix} &= e^{\mathbf{H}t} \begin{bmatrix} \underline{x}(0) \\ \underline{\lambda}(0) \end{bmatrix} \\ &= e^{\mathbf{H}(t-t_f)} \begin{bmatrix} \underline{0} \\ \underline{\lambda}(t_f) \end{bmatrix} \\ &= \begin{bmatrix} \mathbf{E}_{11}(t-t_f) & \mathbf{E}_{12}(t-t_f) \\ \mathbf{E}_{21}(t-t_f) & \mathbf{E}_{22}(t-t_f) \end{bmatrix} \begin{bmatrix} \underline{0} \\ \underline{\lambda}(t_f) \end{bmatrix} \end{aligned} \quad (2.90)$$

From Equation (2.90), the state vector $\underline{x}(t)$ and costate vector $\underline{\lambda}(t)$ can now be obtained through the value of $\underline{\lambda}(t_f)$, which can be set thanks to the value of $\underline{x}(0) = \underline{x}_0$. We get:

$$\begin{aligned} \underline{x}_0 = \underline{x}(0) &= \mathbf{E}_{12}(-t_f) \underline{\lambda}(t_f) \Leftrightarrow \underline{\lambda}(t_f) = \mathbf{E}_{12}^{-1}(-t_f) \underline{x}_0 \\ &\Rightarrow \begin{cases} \underline{x}(t) = \mathbf{E}_{12}(t-t_f) \mathbf{E}_{12}^{-1}(-t_f) \underline{x}_0 \\ \underline{\lambda}(t) = \mathbf{E}_{22}(t-t_f) \mathbf{E}_{12}^{-1}(-t_f) \underline{x}_0 \end{cases} \end{aligned} \quad (2.91)$$

2.5.4 Using Hamilton-Jacobi-Bellman (HJB) equation

Let's apply the Hamilton-Jacobi-Bellman (HJB) partial differential equation (1.66) that we recall hereafter:

$$-\frac{\partial J^*(\underline{x}, t)}{\partial t} = \min_{\underline{u}(t) \in \mathcal{U}} \left(F(\underline{x}, \underline{u}) + \frac{\partial J^*(\underline{x}, t)}{\partial \underline{x}} f(\underline{x}, \underline{u}) \right) \quad (2.92)$$

For linear system with quadratic cost (we remind that $\mathbf{Q} = \mathbf{Q}^T \geq 0$ and $\mathbf{R} = \mathbf{R}^T > 0$) we have:

$$F(\underline{x}, \underline{u}) + \left(\frac{\partial J^*(\underline{x}, t)}{\partial \underline{x}} \right) f(\underline{x}, \underline{u}) = \frac{1}{2} (\underline{x}^T \mathbf{Q} \underline{x} + \underline{u}^T \mathbf{R} \underline{u}) + \left(\frac{\partial J^*(\underline{x}, t)}{\partial \underline{x}} \right) (\mathbf{A} \underline{x} + \mathbf{B} \underline{u}) \quad (2.93)$$

Assuming no constraint on control \underline{u} , the optimal control is computed as follows:

$$\begin{aligned} \min_{\underline{u}(t) \in \mathcal{U}} \left(F(\underline{x}, \underline{u}) + \left(\frac{\partial J^*(\underline{x}, t)}{\partial \underline{x}} \right) f(\underline{x}, \underline{u}) \right) &\Rightarrow \mathbf{R} \underline{u} + \mathbf{B}^T \left(\frac{\partial J^*(\underline{x}, t)}{\partial \underline{x}} \right)^T = 0 \\ &\Leftrightarrow \underline{u} = -\mathbf{R}^{-1} \mathbf{B}^T \left(\frac{\partial J^*(\underline{x}, t)}{\partial \underline{x}} \right)^T \end{aligned} \quad (2.94)$$

Thus, using the fact that $\mathbf{R} = \mathbf{R}^T$, the Hamilton-Jacobi-Bellman (HJB) partial differential equation reads:

$$\begin{aligned} -\frac{\partial J^*(\underline{x}, t)}{\partial t} &= \frac{1}{2} \left(\underline{x}^T \mathbf{Q} \underline{x} + \left(\frac{\partial J^*(\underline{x}, t)}{\partial \underline{x}} \right) \mathbf{B} \mathbf{R}^{-1} \mathbf{B}^T \left(\frac{\partial J^*(\underline{x}, t)}{\partial \underline{x}} \right)^T \right) \\ &\quad + \left(\frac{\partial J^*(\underline{x}, t)}{\partial \underline{x}} \right) \left(\mathbf{A} \underline{x} - \mathbf{B} \mathbf{R}^{-1} \mathbf{B}^T \left(\frac{\partial J^*(\underline{x}, t)}{\partial \underline{x}} \right)^T \right) \\ &= \frac{1}{2} \underline{x}^T \mathbf{Q} \underline{x} - \frac{1}{2} \left(\frac{\partial J^*(\underline{x}, t)}{\partial \underline{x}} \right) \mathbf{B} \mathbf{R}^{-1} \mathbf{B}^T \left(\frac{\partial J^*(\underline{x}, t)}{\partial \underline{x}} \right)^T \\ &\quad + \left(\frac{\partial J^*(\underline{x}, t)}{\partial \underline{x}} \right) \mathbf{A} \underline{x} \end{aligned} \quad (2.95)$$

Assuming that the final state at $t = t_f$ is set to zero, a candidate solution of the Hamilton-Jacobi-Bellman (HJB) partial differential equation is the following where $\mathbf{P}(t) = \mathbf{P}^T(t) \geq 0$:

$$J^*(\underline{x}, t) = \frac{1}{2} \underline{x}^T \mathbf{P}(t) \underline{x} \Rightarrow \begin{cases} \frac{\partial J^*(\underline{x}, t)}{\partial t} = \frac{1}{2} \underline{x}^T \dot{\mathbf{P}}(t) \underline{x} \\ \left(\frac{\partial J^*(\underline{x}, t)}{\partial \underline{x}} \right)^T = \mathbf{P}(t) \underline{x} \end{cases} \quad (2.96)$$

Thus the Hamilton-Jacobi-Bellman (HJB) partial differential equation reads:

$$-\frac{\partial \lambda(t)^T}{\partial t} = -\frac{1}{2} \underline{x}^T \dot{\mathbf{P}}(t) \underline{x} = \frac{1}{2} \underline{x}^T \mathbf{Q} \underline{x} - \frac{1}{2} \underline{x}^T \mathbf{P}(t) \mathbf{B} \mathbf{R}^{-1} \mathbf{B}^T \mathbf{P}(t) \underline{x} + \underline{x}^T \mathbf{P}(t) \mathbf{A} \underline{x} \quad (2.97)$$

Then, using the fact that $\mathbf{P}(t) = \mathbf{P}^T(t)$, we can write:

$$\underline{x}^T \mathbf{P}(t) \mathbf{A} \underline{x} = \underline{x}^T \mathbf{A}^T \mathbf{P}(t) \underline{x} = \frac{1}{2} \underline{x}^T (\mathbf{P}(t) \mathbf{A} + \mathbf{A}^T \mathbf{P}(t)) \underline{x} \quad (2.98)$$

Thus the Hamilton-Jacobi-Bellman (HJB) partial differential equation reads:

$$-\frac{1}{2} \underline{x}^T \dot{\mathbf{P}}(t) \underline{x} = \frac{1}{2} \underline{x}^T \mathbf{Q} \underline{x} - \frac{1}{2} \underline{x}^T \mathbf{P}(t) \mathbf{B} \mathbf{R}^{-1} \mathbf{B}^T \mathbf{P}(t) \underline{x} + \frac{1}{2} \underline{x}^T (\mathbf{P}(t) \mathbf{A} + \mathbf{A}^T \mathbf{P}(t)) \underline{x} \quad (2.99)$$

Because this equation must be true $\forall \underline{x}$, we conclude that $\mathbf{P}(t) = \mathbf{P}^T(t)$ shall solve the following Riccati differential equation:

$$-\dot{\mathbf{P}}(t) = \mathbf{P}(t) \mathbf{A} + \mathbf{A}^T \mathbf{P}(t) - \mathbf{P}(t) \mathbf{B} \mathbf{R}^{-1} \mathbf{B}^T \mathbf{P}(t) + \mathbf{Q} \quad (2.100)$$

Furthermore the terminal condition reads:

$$J^*(\underline{x}, t_f) = G(\underline{x}(t_f)) \Leftrightarrow \frac{1}{2}\underline{x}^T(t_f)\mathbf{P}(t_f)\underline{x}(t_f) = \frac{1}{2}\underline{x}^T(t_f)\mathbf{S}\underline{x}(t_f) \quad (2.101)$$

Because this equation must be true $\forall \underline{x}(t_f)$ we get:

$$\mathbf{P}(t_f) = \mathbf{S} \quad (2.102)$$

2.6 Solving the Riccati differential equation

2.6.1 Scalar Riccati differential equation

In the scalar case the Riccati differential equation has the following form:

$$\dot{P}(t) = f(t) + g(t)P(t) + h(t)P^2(t) \quad (2.103)$$

The general method to solve it when $P(t)$ is a scalar function is the following: let $P_1(t)$ be a particular solution of the scalar Riccati differential equation (2.103) and consider the new function $z(t)$ defined by:

$$Z(t) = \frac{1}{P(t) - P_1(t)} \Leftrightarrow P(t) = P_1(t) + \frac{1}{Z(t)} \quad (2.104)$$

Then the derivative of new variable $z(t)$ leads to:

$$\begin{aligned} \dot{Z} &= -\frac{\dot{P} - \dot{P}_1}{(P - P_1)^2} = -\frac{f(t) + g(t)P(t) + h(t)P^2(t) - f(t) - g(t)P_1(t) - h(t)P_1^2(t)}{(P(t) - P_1(t))^2} \\ \Leftrightarrow \dot{Z} &= -\frac{g(t)(P(t) - P_1(t)) + h(t)(P^2(t) - P_1^2(t))}{(P(t) - P_1(t))^2} = \frac{-g(t)}{P(t) - P_1(t)} - h(t)\frac{P(t) + P_1(t)}{P(t) - P_1(t)} \\ &\Leftrightarrow \dot{Z} = -g(t)Z(t) - h(t)Z(t)(P(t) + P_1(t)) \end{aligned} \quad (2.105)$$

Using the fact that $P(t) = P_1(t) + \frac{1}{Z(t)}$ we finally get:

$$\begin{aligned} \dot{Z} &= -g(t)Z(t) - h(t)Z(t)\left(P_1(t) + \frac{1}{Z(t)} + P_1(t)\right) \\ \Leftrightarrow \dot{Z} &= -Z(t)(2P_1(t)h(t) + g(t)) - h(t) \end{aligned} \quad (2.106)$$

This equation is a linear differential equation satisfied by the new function $z(t)$. Once it is solved, we go back to $P(t)$ via the relation $P(t) = P_1(t) + \frac{1}{Z(t)}$.

2.6.2 Matrix fraction decomposition

The general method which has been presented to solve the Riccati differential equation in the scalar case is not easy to apply when $\mathbf{P}(t)$ is not a scalar function but a matrix. In addition, The Riccati differential equation (2.80) to be solved involves constant matrices \mathbf{A} , \mathbf{B} , \mathbf{R} and \mathbf{Q} and this special case is not exploited in the general method which has been presented. The Riccati differential equation (2.80) can also be solved by using a technique called the matrix fraction decomposition. Let $\mathbf{X}_2(t)$ and $\mathbf{X}_1(t)$ be $n \times n$ square matrices. A matrix product of the type $\mathbf{X}_2(t)\mathbf{X}_1^{-1}(t)$ is called a matrix fraction. In the following, we will

take the derivative of the matrix fraction $\mathbf{X}_2(t)\mathbf{X}_1^{-1}(t)$ with respect to t and use the fact that:

$$\frac{d}{dt}(\mathbf{X}_1^{-1}(t)) = -(\mathbf{X}_1^{-1}(t))\left(\frac{d}{dt}\mathbf{X}_1(t)\right)(\mathbf{X}_1^{-1}(t)) = -(\mathbf{X}_1^{-1}(t))\dot{\mathbf{X}}_1(t)(\mathbf{X}_1^{-1}(t)) \quad (2.107)$$

The preceding equation is a generalisation of the time derivative of the inverse of a scalar function:

$$\frac{d}{dt}f^{-1}(t) = -\frac{\dot{f}(t)}{f(t)^2} \quad (2.108)$$

Let's decompose matrix $\mathbf{P}(t)$ using a matrix fraction decomposition:

$$\mathbf{P}(t) = \mathbf{X}_2(t)\mathbf{X}_1^{-1}(t) \quad (2.109)$$

Applying (2.107) yields:

$$\begin{aligned} \dot{\mathbf{P}}(t) &= \dot{\mathbf{X}}_2(t)\mathbf{X}_1^{-1}(t) + \mathbf{X}_2(t)\frac{d}{dt}\mathbf{X}_1^{-1}(t) \\ \Leftrightarrow \dot{\mathbf{P}}(t) &= \dot{\mathbf{X}}_2(t)\mathbf{X}_1^{-1}(t) - \mathbf{X}_2(t)\mathbf{X}_1^{-1}(t)\dot{\mathbf{X}}_1(t)\mathbf{X}_1^{-1}(t) \end{aligned} \quad (2.110)$$

From the Riccati differential equation (2.80), substitution for $\mathbf{P}(t)$ with $\mathbf{X}_2(t)\mathbf{X}_1^{-1}(t)$ leads to the following:

$$\begin{aligned} \dot{\mathbf{X}}_2(t)\mathbf{X}_1^{-1}(t) - \mathbf{X}_2(t)\mathbf{X}_1^{-1}(t)\dot{\mathbf{X}}_1(t)\mathbf{X}_1^{-1}(t) + \mathbf{X}_2(t)\mathbf{X}_1^{-1}(t)\mathbf{A} \\ - \mathbf{X}_2(t)\mathbf{X}_1^{-1}(t)\mathbf{B}\mathbf{R}^{-1}\mathbf{B}^T\mathbf{X}_2(t)\mathbf{X}_1^{-1}(t) + \mathbf{Q} + \mathbf{A}^T\mathbf{X}_2(t)\mathbf{X}_1^{-1}(t) = \mathbf{0} \end{aligned} \quad (2.111)$$

Multiplying on the right by $\mathbf{X}_1(t)$ yields:

$$\begin{aligned} \dot{\mathbf{X}}_2(t) - \mathbf{X}_2(t)\mathbf{X}_1^{-1}(t)\dot{\mathbf{X}}_1(t) + \mathbf{X}_2(t)\mathbf{X}_1^{-1}(t)\mathbf{A}\mathbf{X}_1(t) \\ - \mathbf{X}_2(t)\mathbf{X}_1^{-1}(t)\mathbf{B}\mathbf{R}^{-1}\mathbf{B}^T\mathbf{X}_2(t) + \mathbf{Q}\mathbf{X}_1(t) + \mathbf{A}^T\mathbf{X}_2(t) = \mathbf{0} \end{aligned} \quad (2.112)$$

Re-arranging the expression and putting $\mathbf{X}_2(t)\mathbf{X}_1^{-1}(t)$ in factor yields:

$$\begin{aligned} \dot{\mathbf{X}}_2(t) + \mathbf{Q}\mathbf{X}_1(t) + \mathbf{A}^T\mathbf{X}_2(t) \\ - \mathbf{X}_2(t)\mathbf{X}_1^{-1}(t)\left(\dot{\mathbf{X}}_1(t) - \mathbf{A}\mathbf{X}_1(t) + \mathbf{B}\mathbf{R}^{-1}\mathbf{B}^T\mathbf{X}_2(t)\right) = \mathbf{0} \end{aligned} \quad (2.113)$$

As a consequence, $\mathbf{X}_2(t)$ and $\mathbf{X}_1(t)$ can be chosen as follows:

$$\begin{cases} \dot{\mathbf{X}}_1(t) = \mathbf{A}\mathbf{X}_1(t) - \mathbf{B}\mathbf{R}^{-1}\mathbf{B}^T\mathbf{X}_2(t) \\ \dot{\mathbf{X}}_2(t) = -\mathbf{Q}\mathbf{X}_1(t) - \mathbf{A}^T\mathbf{X}_2(t) \end{cases} \quad (2.114)$$

Note that equations (2.114) are the linear differential equations with respect to matrices $\mathbf{X}_2(t)$ and $\mathbf{X}_1(t)$. They can be re-written as follows:

$$\frac{d}{dt} \begin{bmatrix} \mathbf{X}_1(t) \\ \mathbf{X}_2(t) \end{bmatrix} = \begin{bmatrix} \mathbf{A} & -\mathbf{B}\mathbf{R}^{-1}\mathbf{B}^T \\ -\mathbf{Q} & -\mathbf{A}^T \end{bmatrix} \begin{bmatrix} \mathbf{X}_1(t) \\ \mathbf{X}_2(t) \end{bmatrix} \quad (2.115)$$

We recognize the Hamiltonian matrix \mathbf{H} which has already been defined in (2.12):

$$\mathbf{H} = \begin{bmatrix} \mathbf{A} & -\mathbf{B}\mathbf{R}^{-1}\mathbf{B}^T \\ -\mathbf{Q} & -\mathbf{A}^T \end{bmatrix} \quad (2.116)$$

Nevertheless $\mathbf{X}_1(t)$ and $\mathbf{X}_2(t)$ are *matrices* in (2.115) whereas $\underline{x}(t)$ and $\underline{\lambda}(t)$ are *vectors* in (2.11). The expression of the numerator $\mathbf{X}_2(t)$ and denominator $\mathbf{X}_1(t)$ of the matrix fraction decomposition of $\mathbf{P}(t)$ can be represented in the following matrix form, where $e^{\mathbf{H}t}$ is a $2n \times 2n$ matrix:

$$\begin{bmatrix} \mathbf{X}_1(t) \\ \mathbf{X}_2(t) \end{bmatrix} = e^{\mathbf{H}t} \begin{bmatrix} \mathbf{X}_1(0) \\ \mathbf{X}_2(0) \end{bmatrix} \quad (2.117)$$

In order to satisfy the constraint at the final time constraint t_f , we do the following choice where \mathbb{I} represents the identity matrix of dimension n :

$$\begin{cases} \mathbf{P}(t_f) = \mathbf{X}_2(t_f)\mathbf{X}_1^{-1}(t_f) \\ \mathbf{P}(t_f) = \mathbf{S} \end{cases} \Rightarrow \begin{bmatrix} \mathbf{X}_1(t_f) \\ \mathbf{X}_2(t_f) \end{bmatrix} = \begin{bmatrix} \mathbb{I} \\ \mathbf{S} \end{bmatrix} \quad (2.118)$$

As a consequence, we get:

$$\begin{bmatrix} \mathbf{X}_1(0) \\ \mathbf{X}_2(0) \end{bmatrix} = e^{-\mathbf{H}t_f} \begin{bmatrix} \mathbb{I} \\ \mathbf{S} \end{bmatrix} \quad (2.119)$$

Using (2.119) within (2.117) leads to the following expression of matrices $\mathbf{X}_1(t)$ and $\mathbf{X}_2(t)$:

$$\begin{bmatrix} \mathbf{X}_1(t) \\ \mathbf{X}_2(t) \end{bmatrix} = e^{\mathbf{H}(t-t_f)} \begin{bmatrix} \mathbb{I} \\ \mathbf{S} \end{bmatrix} \quad (2.120)$$

And the solution $\mathbf{P}(t)$ of the Riccati differential equation (2.80) reads as in (2.74):

$$\mathbf{P}(t) = \mathbf{X}_2(t)\mathbf{X}_1^{-1}(t) \quad (2.121)$$

2.6.3 Examples

Example 1

Given the following scalar plant:

$$\begin{cases} \dot{x}(t) = ax(t) + bu(t) \\ x(0) = x_0 \end{cases} \quad (2.122)$$

Find control $u(t)$ which minimizes the following performance index where $\mathbf{S} \geq 0$ and $\rho > 0$:

$$J = \frac{1}{2}x^T(t_f)\mathbf{S}x(t_f) + \frac{1}{2} \int_0^{t_f} \rho u^2(t) dt \quad (2.123)$$

Let's introduce the Hamiltonian matrix \mathbf{H} defined by:

$$\mathbf{H} = \begin{bmatrix} \mathbf{A} & -\mathbf{B}\mathbf{R}^{-1}\mathbf{B}^T \\ -\mathbf{Q} & -\mathbf{A}^T \end{bmatrix} = \begin{bmatrix} a & \frac{-b^2}{\rho} \\ 0 & -a \end{bmatrix} \quad (2.124)$$

Denoting by s the Laplace variable, the exponential of matrix $e^{\mathbf{H}t}$ is obtained thanks to the inverse of the Laplace transform, which is denoted \mathcal{L}^{-1} :

$$\begin{aligned}
e^{\mathbf{H}t} &= \mathcal{L}^{-1} \left((sI - \mathbf{H})^{-1} \right) = \mathcal{L}^{-1} \left(\left[\begin{array}{cc} s-a & b^2/\rho \\ 0 & s+a \end{array} \right]^{-1} \right) \\
&= \mathcal{L}^{-1} \left(\frac{1}{(s-a)(s+a)} \left[\begin{array}{cc} s+a & -b^2/\rho \\ 0 & s-a \end{array} \right] \right) \\
&= \mathcal{L}^{-1} \left(\left[\begin{array}{cc} \frac{1}{s-a} & \frac{-b^2}{\rho(s^2-a^2)} \\ 0 & \frac{1}{s+a} \end{array} \right] \right) \\
&= \begin{bmatrix} e^{at} & \frac{-b^2(e^{at}-e^{-at})}{2\rho a} \\ 0 & e^{-at} \end{bmatrix}
\end{aligned} \tag{2.125}$$

Matrices $\mathbf{X}_1(t)$ and $\mathbf{X}_2(t)$ are then obtained thanks to (2.120):

$$\begin{aligned}
\begin{bmatrix} \mathbf{X}_1(t) \\ \mathbf{X}_2(t) \end{bmatrix} &= e^{\mathbf{H}(t-t_f)} \begin{bmatrix} \mathbb{I} \\ \mathbf{S} \end{bmatrix} \\
&= \begin{bmatrix} e^{a(t-t_f)} & \frac{-b^2(e^{a(t-t_f)}-e^{-a(t-t_f)})}{2\rho a} \\ 0 & e^{-a(t-t_f)} \end{bmatrix} \begin{bmatrix} 1 \\ \mathbf{S} \end{bmatrix} \\
&= \begin{bmatrix} e^{a(t-t_f)} - \frac{\mathbf{S}b^2(e^{a(t-t_f)}-e^{-a(t-t_f)})}{2\rho a} \\ \mathbf{S}e^{-a(t-t_f)} \end{bmatrix}
\end{aligned} \tag{2.126}$$

From (2.121) we finally get the solution $\mathbf{P}(t)$ of the Riccati differential equation (2.80) as follows:

$$\begin{aligned}
\mathbf{P}(t) &= \mathbf{X}_2(t)\mathbf{X}_1^{-1}(t) \\
&= \frac{\mathbf{S}e^{-a(t-t_f)}}{e^{a(t-t_f)} - \frac{\mathbf{S}b^2(e^{a(t-t_f)}-e^{-a(t-t_f)})}{2\rho a}} \\
&= \frac{\mathbf{S}}{e^{2a(t-t_f)} + \frac{\mathbf{S}b^2(1-e^{2a(t-t_f)})}{2\rho a}}
\end{aligned} \tag{2.127}$$

Finally the optimal control is:

$$\begin{aligned}
u(t) &= -\mathbf{K}(t)x(t) \\
&= -\mathbf{R}^{-1}\mathbf{B}^T\mathbf{P}(t)x(t) \\
&= -\frac{b}{\rho}\mathbf{P}(t)x(t) \\
&= \frac{-b\mathbf{S}}{\rho e^{2a(t-t_f)} + \frac{\mathbf{S}b^2(1-e^{2a(t-t_f)})}{2a}}x(t)
\end{aligned} \tag{2.128}$$

If we want to ensure that the optimal control drives $x(t_f)$ exactly to zero, we can let $\mathbf{S} \rightarrow \infty$ to weight more heavily in the performance index J . Then:

$$u(t) = \frac{-2ab}{b^2(1 - e^{2a(t-t_f)})} x(t) = \frac{-2a e^{-a(t-t_f)}}{b(e^{-a(t-t_f)} - e^{a(t-t_f)})} x(t) \quad (2.129)$$

Example 2

Given the following plant, which actually represents a double integrator:

$$\begin{bmatrix} \dot{x}_1(t) \\ \dot{x}_2(t) \end{bmatrix} = \begin{bmatrix} 0 & 1 \\ 0 & 0 \end{bmatrix} \begin{bmatrix} x_1(t) \\ x_2(t) \end{bmatrix} + \begin{bmatrix} 0 \\ 1 \end{bmatrix} \underline{u}(t) \quad (2.130)$$

Find control $\underline{u}(t)$ which minimizes the following performance index:

$$J(\underline{u}(t)) = \frac{1}{2} \underline{x}^T(t_f) \mathbf{S} \underline{x}(t_f) + \frac{1}{2} \int_0^{t_f} \underline{u}^2(t) dt \quad (2.131)$$

Where weighting matrix \mathbf{S} reads as follows:

$$\mathbf{S} = \mathbf{S}^T = \begin{bmatrix} s_p & 0 \\ 0 & s_v \end{bmatrix} \geq 0 \quad (2.132)$$

Hamiltonian matrix \mathbf{H} as defined in (2.116) reads

$$\mathbf{H} = \begin{bmatrix} \mathbf{A} & -\mathbf{B}\mathbf{R}^{-1}\mathbf{B}^T \\ -\mathbf{Q} & -\mathbf{A}^T \end{bmatrix} = \begin{bmatrix} 0 & 1 & 0 & 0 \\ 0 & 0 & 0 & -1 \\ 0 & 0 & 0 & 0 \\ 0 & 0 & -1 & 0 \end{bmatrix} \quad (2.133)$$

In order to compute $e^{\mathbf{H}t}$ we use the following relationship where \mathcal{L}^{-1} stands for the inverse Laplace transform:

$$e^{\mathbf{H}t} = \mathcal{L}^{-1} \left[(s\mathbb{I} - \mathbf{H})^{-1} \right] \quad (2.134)$$

We get:

$$\begin{aligned} s\mathbb{I} - \mathbf{H} &= \begin{bmatrix} s & -1 & 0 & 0 \\ 0 & s & 0 & 1 \\ 0 & 0 & s & 0 \\ 0 & 0 & 1 & s \end{bmatrix} \Rightarrow (s\mathbb{I} - \mathbf{H})^{-1} = \begin{bmatrix} \frac{1}{s} & \frac{1}{s^2} & \frac{1}{s^4} & -\frac{1}{s^3} \\ 0 & \frac{1}{s} & \frac{1}{s^3} & -\frac{1}{s^2} \\ 0 & 0 & \frac{1}{s} & 0 \\ 0 & 0 & -\frac{1}{s^2} & \frac{1}{s} \end{bmatrix} \\ \Rightarrow e^{\mathbf{H}t} &= \mathcal{L}^{-1} \left[(s\mathbb{I} - \mathbf{H})^{-1} \right] = \begin{bmatrix} 1 & t & \frac{t^3}{6} & -\frac{t^2}{2} \\ 0 & 1 & \frac{t^2}{2} & -t \\ 0 & 0 & 1 & 0 \\ 0 & 0 & -t & 1 \end{bmatrix} \end{aligned} \quad (2.135)$$

Matrices $\mathbf{X}_1(t)$ and $\mathbf{X}_2(t)$ are then obtained thanks to (2.120):

$$\begin{aligned}
\begin{bmatrix} \mathbf{X}_1(t) \\ \mathbf{X}_2(t) \end{bmatrix} &= e^{\mathbf{H}(t-t_f)} \begin{bmatrix} \mathbb{I} \\ \mathbf{S} \end{bmatrix} \\
&= \begin{bmatrix} 1 & t-t_f & \frac{(t-t_f)^3}{6} & -\frac{(t-t_f)^2}{2} \\ 0 & 1 & \frac{(t-t_f)^2}{2} & -(t-t_f) \\ 0 & 0 & 1 & 0 \\ 0 & 0 & -(t-t_f) & 1 \end{bmatrix} \begin{bmatrix} 1 & 0 \\ 0 & 1 \\ s_p & 0 \\ 0 & s_v \end{bmatrix} \\
&= \begin{bmatrix} 1 + s_p \frac{(t-t_f)^3}{6} & t-t_f - s_v \frac{(t-t_f)^2}{2} \\ s_p \frac{(t-t_f)^2}{2} & 1 - s_v(t-t_f) \\ s_p & 0 \\ -s_p(t-t_f) & s_v \end{bmatrix}
\end{aligned} \tag{2.136}$$

From (2.121) we finally get the solution $\mathbf{P}(t)$ of the Riccati differential equation (2.80) as follows:

$$\begin{aligned}
\mathbf{P}(t) &= \mathbf{X}_2(t)\mathbf{X}_1^{-1}(t) \\
&= \begin{bmatrix} s_p & 0 \\ -s_p(t-t_f) & s_v \end{bmatrix} \begin{bmatrix} 1 + s_p \frac{(t-t_f)^3}{6} & t-t_f - s_v \frac{(t-t_f)^2}{2} \\ s_p \frac{(t-t_f)^2}{2} & 1 - s_v(t-t_f) \end{bmatrix}^{-1} \\
&= \frac{1}{\Delta} \begin{bmatrix} s_p & 0 \\ -s_p(t-t_f) & s_v \end{bmatrix} \begin{bmatrix} 1 - s_v(t-t_f) & t_f - t + s_v \frac{(t-t_f)^2}{2} \\ -s_p \frac{(t-t_f)^2}{2} & 1 + s_p \frac{(t-t_f)^3}{6} \end{bmatrix}
\end{aligned} \tag{2.137}$$

where:

$$\Delta = \left(1 + s_p \frac{(t-t_f)^3}{6}\right) (1 - s_v(t-t_f)) - s_p \frac{(t-t_f)^2}{2} \left(t-t_f - s_v \frac{(t-t_f)^2}{2}\right) \tag{2.138}$$

2.7 Second order necessary condition for optimality

It is worth noticing that the second order necessary condition for optimality to achieve a minimum cost is the positive semi-definiteness of the Hessian matrix of the Hamiltonian along an optimal trajectory (see (1.134)). This condition is always satisfied as soon as $\mathbf{R} > 0$. Indeed we get from (2.5):

$$\frac{\partial^2 H}{\partial \underline{u}^2} = \mathbf{H}_{uu} = \mathbf{R} > 0 \tag{2.139}$$

2.8 Finite horizon LQ regulator with cross term in the performance index

Consider the following time invariant state differential equation:

$$\begin{cases} \dot{\mathbf{x}}(t) = \mathbf{A}\mathbf{x}(t) + \mathbf{B}\underline{u}(t) \\ \mathbf{x}(0) = \underline{x}_0 \end{cases} \tag{2.140}$$

Where:

- \mathbf{A} is the state (or system) matrix
- \mathbf{B} is the input matrix
- $\underline{x}(t)$ is the state vector of dimension n
- $\underline{u}(t)$ is the control vector of dimension m

We will assume that the pair (\mathbf{A}, \mathbf{B}) is controllable. The purpose of this section is to explicit the control $\underline{u}(t)$ which minimizes the following quadratic performance index with cross terms:

$$J(\underline{u}(t)) = \frac{1}{2} \int_0^{t_f} \underline{x}^T(t) \mathbf{Q} \underline{x}(t) + \underline{u}^T(t) \mathbf{R} \underline{u}(t) + 2 \underline{x}^T(t) \mathbf{S} \underline{u}(t) dt \quad (2.141)$$

With the constraint on terminal state:

$$\underline{x}(t_f) = \underline{0} \quad (2.142)$$

Matrices \mathbf{S} and \mathbf{Q} are symmetric positive semi-definite and matrix \mathbf{R} symmetric positive definite:

$$\begin{cases} \mathbf{S} = \mathbf{S}^T \geq 0 \\ \mathbf{Q} = \mathbf{Q}^T \geq 0 \\ \mathbf{R} = \mathbf{R}^T > 0 \end{cases} \quad (2.143)$$

It can be seen that:

$$\underline{x}^T(t) \mathbf{Q} \underline{x}(t) + \underline{u}^T(t) \mathbf{R} \underline{u}(t) + 2 \underline{x}^T(t) \mathbf{S} \underline{u}(t) = \underline{x}^T(t) \mathbf{Q}_m \underline{x}(t) + \underline{v}^T(t) \mathbf{R} \underline{v}(t) \quad (2.144)$$

Where:

$$\begin{cases} \mathbf{Q}_m = \mathbf{Q} - \mathbf{S} \mathbf{R}^{-1} \mathbf{S}^T \\ \underline{v}(t) = \underline{u}(t) + \mathbf{R}^{-1} \mathbf{S}^T \underline{x}(t) \end{cases} \quad (2.145)$$

Hence cost (2.141) to be minimized can be rewritten as:

$$J(\underline{u}(t)) = \frac{1}{2} \int_0^\infty \underline{x}^T(t) \mathbf{Q}_m \underline{x}(t) + \underline{v}^T(t) \mathbf{R} \underline{v}(t) dt \quad (2.146)$$

Furthermore (2.140) is rewritten as follows, where $\underline{v}(t)$ appears as the control vector rather than $\underline{u}(t)$. Using $\underline{u}(t) = \underline{v}(t) - \mathbf{R}^{-1} \mathbf{S}^T \underline{x}(t)$ in (2.140) leads to the following state equation:

$$\begin{aligned} \dot{\underline{x}}(t) &= \mathbf{A} \underline{x}(t) + \mathbf{B} (\underline{v}(t) - \mathbf{R}^{-1} \mathbf{S}^T \underline{x}(t)) \\ &= (\mathbf{A} - \mathbf{B} \mathbf{R}^{-1} \mathbf{S}^T) \underline{x}(t) + \mathbf{B} \underline{v}(t) \\ &= \mathbf{A}_m \underline{x}(t) + \mathbf{B} \underline{v}(t) \end{aligned} \quad (2.147)$$

We will assume that symmetric matrix \mathbf{Q}_m is positive semi-definite:

$$\mathbf{Q}_m = \mathbf{Q} - \mathbf{S} \mathbf{R}^{-1} \mathbf{S}^T \geq 0 \quad (2.148)$$

Hamiltonian matrix \mathbf{H} reads:

$$\mathbf{H} = \begin{bmatrix} \mathbf{A}_m & -\mathbf{B} \mathbf{R}^{-1} \mathbf{B}^T \\ -\mathbf{Q}_m & -\mathbf{A}_m^T \end{bmatrix} = \begin{bmatrix} \mathbf{A} - \mathbf{B} \mathbf{R}^{-1} \mathbf{S}^T & -\mathbf{B} \mathbf{R}^{-1} \mathbf{B}^T \\ -\mathbf{Q} + \mathbf{S} \mathbf{R}^{-1} \mathbf{S}^T & -\mathbf{A}^T + \mathbf{S} \mathbf{R}^{-1} \mathbf{S}^T \end{bmatrix} \quad (2.149)$$

The problem can be solved through the following Hamiltonian system whose state is obtained by extending the state $\underline{x}(t)$ of system (2.140) with costate $\underline{\lambda}(t)$:

$$\begin{bmatrix} \dot{\underline{x}}(t) \\ \dot{\underline{\lambda}}(t) \end{bmatrix} = \begin{bmatrix} \mathbf{A} - \mathbf{B}\mathbf{R}^{-1}\mathbf{S}^T & -\mathbf{B}\mathbf{R}^{-1}\mathbf{B}^T \\ -\mathbf{Q} + \mathbf{S}\mathbf{R}^{-1}\mathbf{S}^T & -\mathbf{A}^T + \mathbf{S}\mathbf{R}^{-1}\mathbf{S}^T \end{bmatrix} \begin{bmatrix} \underline{x}(t) \\ \underline{\lambda}(t) \end{bmatrix} = \mathbf{H} \begin{bmatrix} \underline{x}(t) \\ \underline{\lambda}(t) \end{bmatrix} \quad (2.150)$$

Ntogramatzidis¹ has shown the results presented hereafter: let \mathbf{P}_1 and \mathbf{P}_2 be the *positive semi-definite solutions* of the following continuous time algebraic Riccati equations:

$$\begin{cases} \mathbf{0} = \mathbf{A}^T\mathbf{P}_1 + \mathbf{P}_1\mathbf{A} - (\mathbf{S} + \mathbf{P}_1\mathbf{B})\mathbf{R}^{-1}(\mathbf{S} + \mathbf{P}_1\mathbf{B})^T + \mathbf{Q} \\ \mathbf{0} = -\mathbf{A}^T\mathbf{P}_2 - \mathbf{P}_2\mathbf{A} - (\mathbf{S} - \mathbf{P}_2\mathbf{B})\mathbf{R}^{-1}(\mathbf{S} - \mathbf{P}_2\mathbf{B})^T + \mathbf{Q} \end{cases} \quad (2.151)$$

Notice that pair (\mathbf{A}, \mathbf{B}) has been replaced by $(-\mathbf{A}, -\mathbf{B})$ in the second equation. We will denote by \mathbf{K}_1 and \mathbf{K}_2 the following *infinite* horizon gain matrices:

$$\begin{cases} \mathbf{K}_1 = \mathbf{R}^{-1}(\mathbf{S}^T + \mathbf{B}^T\mathbf{P}_1) \\ \mathbf{K}_2 = \mathbf{R}^{-1}(\mathbf{S}^T - \mathbf{B}^T\mathbf{P}_2) \end{cases} \quad (2.152)$$

Then the optimal control reads:

$$\underline{u}(t) = \begin{cases} -\mathbf{K}(t)\underline{x}(t) & \forall 0 \leq t < t_f \\ 0 & \text{for } t = t_f \end{cases} \quad (2.153)$$

Where:

$$\begin{cases} \mathbf{K}(t) = \mathbf{R}^{-1}(\mathbf{S}^T + \mathbf{B}^T\mathbf{P}(t)) \\ \mathbf{P}(t) = \mathbf{X}_2(t)\mathbf{X}_1^{-1}(t) \end{cases} \quad (2.154)$$

And:

$$\begin{cases} \mathbf{X}_1(t) = e^{(\mathbf{A}-\mathbf{B}\mathbf{K}_1)t} - e^{(\mathbf{A}-\mathbf{B}\mathbf{K}_2)(t-t_f)}e^{(\mathbf{A}-\mathbf{B}\mathbf{K}_1)t_f} \\ \mathbf{X}_2(t) = \mathbf{P}_1e^{(\mathbf{A}-\mathbf{B}\mathbf{K}_1)t} + \mathbf{P}_2e^{(\mathbf{A}-\mathbf{B}\mathbf{K}_2)(t-t_f)}e^{(\mathbf{A}-\mathbf{B}\mathbf{K}_1)t_f} \end{cases} \quad (2.155)$$

Matrix $\mathbf{P}(t)$ satisfy the following Riccati differential equation:

$$-\dot{\mathbf{P}}(t) = \mathbf{A}^T\mathbf{P} + \mathbf{P}\mathbf{A} - (\mathbf{S} + \mathbf{B}\mathbf{P}(t))\mathbf{R}^{-1}(\mathbf{S} + \mathbf{B}\mathbf{P}(t))^T + \mathbf{Q} \quad (2.156)$$

Furthermore the optimal state $\underline{x}(t)$ and costate $\underline{\lambda}(t)$ have the following expressions:

$$\begin{cases} \underline{x}(t) = \mathbf{X}_1(t)\mathbf{X}_1^{-1}(0)\underline{x}_0 \\ \underline{\lambda}(t) = \mathbf{X}_2(t)\mathbf{X}_1^{-1}(0)\underline{x}_0 \end{cases} \quad (2.157)$$

It is clear that equations (2.91) and (2.157) are the same. Nevertheless when the Hamiltonian matrix \mathbf{H} has eigenvalues on the imaginary axis then algebraic Riccati equations (2.151) are unsolvable and equation (2.91) shall then be used.

¹Lorenzo Ntogramatzidis, A simple solution to the finite-horizon LQ problem with zero terminal state, *Kybernetika* - 39(4):483-492, January 2003

2.9 Minimum cost achieved

The minimum cost achieved is given by:

$$J^* = J(\underline{u}^*(t)) = \frac{1}{2} \underline{x}^T(0) \mathbf{P}(0) \underline{x}(0) \quad (2.158)$$

Indeed, from the Riccati equation (2.80), we deduce that:

$$\begin{aligned} & \underline{x}^T \left(\dot{\mathbf{P}} + \mathbf{P}\mathbf{A} + \mathbf{A}^T\mathbf{P} - \mathbf{P}\mathbf{B}\mathbf{R}^{-1}\mathbf{B}^T\mathbf{P} + \mathbf{Q} \right) \underline{x} = \mathbf{0} \\ \Leftrightarrow & \underline{x}^T \dot{\mathbf{P}} \underline{x} + \underline{x}^T \mathbf{P}\mathbf{A} \underline{x} + \underline{x}^T \mathbf{A}^T \mathbf{P} \underline{x} - \underline{x}^T \mathbf{P}\mathbf{B}\mathbf{R}^{-1}\mathbf{B}^T \mathbf{P} \underline{x} + \underline{x}^T \mathbf{Q} \underline{x} = \mathbf{0} \quad (2.159) \\ \Leftrightarrow & \underline{x}^T \dot{\mathbf{P}} \underline{x} + \underline{x}^T \mathbf{P}\mathbf{A} \underline{x} + (\underline{x}^T \mathbf{P}\mathbf{A} \underline{x})^T - \underline{x}^T \mathbf{P}\mathbf{B}\mathbf{R}^{-1}\mathbf{B}^T \mathbf{P} \underline{x} + \underline{x}^T \mathbf{Q} \underline{x} = \mathbf{0} \end{aligned}$$

Taking into account the fact that $\mathbf{P} = \mathbf{P}^T > 0$, $\mathbf{R} = \mathbf{R}^T > 0$ as well as (2.1), (2.75) and (2.76), it can be shown that:

$$\begin{cases} \underline{x}^T \mathbf{P}\mathbf{B}\mathbf{R}^{-1}\mathbf{B}^T \mathbf{P} \underline{x} &= -\underline{x}^T \mathbf{P}\mathbf{B}\underline{u}^* \\ &= -\underline{x}^T \mathbf{P}\mathbf{B}\mathbf{R}^{-1}\mathbf{R}\underline{u}^* \\ &= \underline{u}^{*T} \mathbf{R}\underline{u}^* \\ \underline{x}^T \mathbf{P}\mathbf{A} \underline{x} &= \underline{x}^T \mathbf{P} (\mathbf{A}\underline{x} + \mathbf{B}\underline{u}^* - \mathbf{B}\underline{u}^*) \\ &= \underline{x}^T \mathbf{P}\dot{\underline{x}} - \underline{x}^T \mathbf{P}\mathbf{B}\underline{u}^* \\ &= \underline{x}^T \mathbf{P}\dot{\underline{x}} + \underline{u}^{*T} \mathbf{R}\underline{u}^* \\ \Rightarrow \underline{x}^T \dot{\mathbf{P}} \underline{x} + \underline{x}^T \mathbf{P}\mathbf{A} \underline{x} &+ (\underline{x}^T \mathbf{P}\mathbf{A} \underline{x})^T - \underline{x}^T \mathbf{P}\mathbf{B}\mathbf{R}^{-1}\mathbf{B}^T \mathbf{P} \underline{x} \\ &= \underline{x}^T \dot{\mathbf{P}} \underline{x} + \underline{x}^T \mathbf{P}\dot{\underline{x}} + \dot{\underline{x}}^T \mathbf{P} \underline{x} + \underline{u}^{*T} \mathbf{R}\underline{u}^* \\ &= \frac{d}{dt} (\underline{x}^T \mathbf{P} \underline{x}) + \underline{u}^{*T} \mathbf{R}\underline{u}^* \end{cases} \quad (2.160)$$

As a consequence equation (2.159) can be written as follows:

$$\frac{d}{dt} (\underline{x}^T(t) \mathbf{P}(t) \underline{x}(t)) + \underline{x}^T(t) \mathbf{Q} \underline{x}(t) + \underline{u}^{*T}(t) \mathbf{R}\underline{u}^*(t) = 0 \quad (2.161)$$

And the performance index (2.2) to be minimized can be re-written as:

$$\begin{aligned} J(\underline{u}^*(t)) &= \frac{1}{2} \underline{x}^T(t_f) \mathbf{S} \underline{x}(t_f) + \frac{1}{2} \int_0^{t_f} \underline{x}^T(t) \mathbf{Q} \underline{x}(t) + \underline{u}^{*T}(t) \mathbf{R}\underline{u}^*(t) dt \\ \Leftrightarrow J(\underline{u}^*(t)) &= \frac{1}{2} \left(\underline{x}^T(t_f) \mathbf{S} \underline{x}(t_f) - \int_0^{t_f} \frac{d}{dt} (\underline{x}^T(t) \mathbf{P}(t) \underline{x}(t)) dt \right) \quad (2.162) \\ \Leftrightarrow J(\underline{u}^*(t)) &= \frac{1}{2} (\underline{x}^T(t_f) \mathbf{S} \underline{x}(t_f) - \underline{x}^T(t_f) \mathbf{P}(t_f) \underline{x}(t_f) + \underline{x}^T(0) \mathbf{P}(0) \underline{x}(0)) \end{aligned}$$

Then taking into account the boundary conditions $\mathbf{P}(t_f) = \mathbf{S}$ we finally get (2.158).

2.10 Extension to nonlinear system affine in control

We consider the following finite horizon optimal control problem consisting in finding the control \underline{u} that minimizes the following performance index where $q(\underline{x})$ is positive semi-definite and $\mathbf{R} = \mathbf{R}^T > 0$:

$$J(\underline{u}(t)) = G(\underline{x}(t_f)) + \frac{1}{2} \int_0^{t_f} (q(\underline{x}) + \underline{u}^T \mathbf{R} \underline{u}) dt \quad (2.163)$$

under the *constraint* that the system is nonlinear but affine in control:

$$\begin{cases} \dot{\underline{x}} = \underline{f}(\underline{x}) + \underline{g}(\underline{x}) \underline{u} \\ \underline{x}(0) = \underline{x}_0 \end{cases} \quad (2.164)$$

Assuming no constraint, control $\underline{u}^*(t)$ that *minimizes* the performance index $J(\underline{u}(t))$ is defined by:

$$\underline{u}^*(t) = -\mathbf{R}^{-1} \underline{g}^T(\underline{x}) \underline{\lambda}(t) \quad (2.165)$$

where:

$$\begin{aligned} \dot{\underline{\lambda}}(t) &= - \left(\frac{1}{2} \left(\frac{\partial q(\underline{x})}{\partial \underline{x}} \right)^T + \frac{\partial (f(\underline{x}) + \underline{g}(\underline{x}) \underline{u}^*)}{\partial \underline{x}} \underline{\lambda}(t) \right) \\ &= - \left(\frac{1}{2} \left(\frac{\partial q(\underline{x})}{\partial \underline{x}} \right)^T + \frac{\partial (f(\underline{x}) - \underline{g}(\underline{x}) \mathbf{R}^{-1} \underline{g}^T(\underline{x}) \underline{\lambda}(t))}{\partial \underline{x}} \underline{\lambda}(t) \right) \end{aligned} \quad (2.166)$$

For boundary value problems, efficient minimization of the Hamiltonian is possible².

²Todorov E. and Tassa Y., Iterative Local Dynamic Programming, IEEE ADPRL, 2009

Chapter 3

Infinite Horizon Linear Quadratic Regulator (LQR)

3.1 Problem to be solved

We recall that we consider the following linear time invariant system, where $\underline{x}(t)$ is the state vector of dimension n , $\underline{u}(t)$ is the control vector of dimension m and $\underline{z}(t)$ is the *controlled* output (that is not the *actual* output of the system but the output of *interest* for the design)

$$\begin{cases} \dot{\underline{x}}(t) = \mathbf{A}\underline{x}(t) + \mathbf{B}\underline{u}(t) \\ \underline{z}(t) = \mathbf{N}\underline{x}(t) \\ \underline{x}(0) = \underline{x}_0 \end{cases} \quad (3.1)$$

In this chapter we will focus on the case where the final time t_f tends toward infinity ($t_f \rightarrow \infty$). The performance index to be minimized turns out to be:

$$J(\underline{u}(t)) = \frac{1}{2} \int_0^\infty (\underline{x}^T(t)\mathbf{Q}\underline{x}(t) + \underline{u}^T(t)\mathbf{R}\underline{u}(t)) dt \quad (3.2)$$

Where $\mathbf{Q} = \mathbf{N}^T\mathbf{N}$ (thus \mathbf{Q} is symmetric and positive semi-definite), and \mathbf{R} is a symmetric and positive definite matrix.

When final time t_f is set to infinity, the Kalman gain $\mathbf{K}(t)$ which has been computed in the previous chapter becomes constant. As a consequence, the control is easier to implement as far as it is no more necessary to integrate the differential Riccati equation and to store the gain $\mathbf{K}(t)$ before applying the control. In practice *infinity* means that final time t_f becomes large when compared to the time constants of the plant.

3.2 Stabilizability and detectability

We will assume in the following that (\mathbf{A}, \mathbf{B}) is stabilizable and (\mathbf{A}, \mathbf{N}) is detectable. We recall that the pair (\mathbf{A}, \mathbf{B}) is said stabilizable if the uncontrollable eigenvalues of \mathbf{A} , if any, have negative real parts. Thus even though not all system modes are controllable, the ones that are not controllable do not require stabilization.

Similarly the pair (\mathbf{A}, \mathbf{N}) is said detectable if the unobservable eigenvalues of \mathbf{A} , if any, have negative real parts. Thus even though not all system modes are observable, the ones that are not observable do not require stabilization. We may use the Kalman test to check the controllability of the system:

$$\text{Rank} [\mathbf{B} \quad \mathbf{AB} \quad \dots \quad \mathbf{A}^{n-1}\mathbf{B}] = n \quad \text{where } n = \text{size of state vector } \underline{x} \quad (3.3)$$

Or equivalently the Popov-Belevitch-Hautus (*PBH*) test which shall be applied to all eigenvalues of \mathbf{A} , denoted λ_i , to check the controllability of the system, or only on the eigenvalues which are not contained in the left half plane to check the stabilizability of the system:

$$\text{Rank} [\mathbf{A} - \lambda_i \mathbb{I} \quad \mathbf{B}] = n \quad \begin{cases} \forall \lambda_i \text{ for controllability} \\ \forall \lambda_i \text{ s.t. } \Re(\lambda_i) \geq 0 \text{ for stabilizability} \end{cases} \quad (3.4)$$

Similarly we may use the Kalman test to check the observability of the system:

$$\text{Rank} \begin{bmatrix} \mathbf{N} \\ \mathbf{NA} \\ \dots \\ \mathbf{NA}^{n-1} \end{bmatrix} = n \quad \text{where } n = \text{size of state vector } \underline{x} \quad (3.5)$$

Or equivalently the Popov-Belevitch-Hautus (*PBH*) test which shall be applied to all eigenvalues of \mathbf{A} , denoted λ_i , to check the observability of the system, or only on the eigenvalues which are not contained in the left half plane to check the detectability of the system:

$$\text{Rank} \begin{bmatrix} \mathbf{A} - \lambda_i \mathbb{I} \\ \mathbf{N} \end{bmatrix} = n \quad \begin{cases} \forall \lambda_i \text{ for observability} \\ \forall \lambda_i \text{ s.t. } \Re(\lambda_i) \geq 0 \text{ for detectability} \end{cases} \quad (3.6)$$

3.3 Algebraic Riccati equation

When final time t_f tends toward infinity the matrix $\mathbf{P}(t)$ turns out to be a constant symmetric positive definite matrix denoted \mathbf{P} . The *Riccati* equation (2.80) reduces to an algebraic equation, which is known as the *algebraic Riccati equation* (ARE):

$$\mathbf{A}^T \mathbf{P} + \mathbf{P} \mathbf{A} - \mathbf{P} \mathbf{B} \mathbf{R}^{-1} \mathbf{B}^T \mathbf{P} + \mathbf{Q} = \mathbf{0} \quad (3.7)$$

It is worth noticing that the *algebraic Riccati* equation (3.7) has two solutions: one is positive semi-definite and the other is negative semi-definite. The solution of the optimal control problem only retains the *positive semi-definite solution of the algebraic Riccati* equation.

The convergence of $\lim_{t_f \rightarrow \infty} \mathbf{P}(t) \rightarrow \mathbf{P}$ where $\mathbf{P} \geq 0$ is some positive semi-definite symmetric constant matrix is guaranteed by the stabilizability assumption (\mathbf{P}^T is indeed a solution of the algebraic Riccati equation (3.7)). Since the matrix $\mathbf{P} = \mathbf{P}^T \geq 0$ is constant, the optimal gain $\mathbf{K}(t)$ also turns out to be also a constant denoted \mathbf{K} . The optimal gain \mathbf{K} and the optimal stabilizing control $\underline{u}(t)$ are then defined as follows:

$$\begin{cases} \underline{u}(t) = -\mathbf{K} \underline{x}(t) \\ \mathbf{K} = \mathbf{R}^{-1} \mathbf{B}^T \mathbf{P} \end{cases} \quad (3.8)$$

The need for the detectability assumption is to ensure that the optimal control computed using the $\lim_{t_f \rightarrow \infty} \mathbf{P}(t)$ generates a feedback gain $\mathbf{K} = \mathbf{R}^{-1} \mathbf{B}^T \mathbf{P}$ that stabilizes the plant, i.e. all the eigenvalues of $\mathbf{A} - \mathbf{BK}$ lie on the open left half plane. In addition, it can be shown that the minimum cost achieved is given by:

$$J^* = \frac{1}{2} \underline{x}^T(0) \mathbf{P} \underline{x}(0) \quad (3.9)$$

To get this result first we notice that the Hamiltonian (1.56) reads:

$$H(\underline{x}, \underline{u}, \underline{\lambda}) = \frac{1}{2} (\underline{x}^T(t) \mathbf{Q} \underline{x}(t) + \underline{u}^T(t) \mathbf{R} \underline{u}(t)) + \underline{\lambda}^T(t) (\mathbf{A} \underline{x}(t) + \mathbf{B} \underline{u}(t)) \quad (3.10)$$

The necessary condition for optimality (1.71) yields:

$$\frac{\partial H}{\partial \underline{u}} = \mathbf{R} \underline{u}(t) + \mathbf{B}^T \underline{\lambda}(t) = 0 \quad (3.11)$$

Taking into account that \mathbf{R} is a symmetric matrix, we get:

$$\underline{u}(t) = -\mathbf{R}^{-1} \mathbf{B}^T \underline{\lambda}(t) \quad (3.12)$$

Eliminating $\underline{u}(t)$ in equation (3.1) reads:

$$\dot{\underline{x}}(t) = \mathbf{A} \underline{x}(t) - \mathbf{B} \mathbf{R}^{-1} \mathbf{B}^T \underline{\lambda}(t) \quad (3.13)$$

The dynamics of Lagrange multipliers $\underline{\lambda}(t)$ is given by (1.62):

$$\dot{\underline{\lambda}}(t) = -\frac{\partial H}{\partial \underline{x}} = -\mathbf{Q} \underline{x}(t) - \mathbf{A}^T \underline{\lambda}(t) \quad (3.14)$$

The key point in the LQR design is that Lagrange multipliers $\underline{\lambda}(t)$ are now assume to linearly depends on state vector $\underline{x}(t)$ through a constant symmetric positive definite matrix denoted \mathbf{P} :

$$\underline{\lambda}(t) = \mathbf{P} \underline{x}(t) \text{ where } \mathbf{P} = \mathbf{P}^T \geq 0 \quad (3.15)$$

By taking the time derivative of the Lagrange multipliers $\underline{\lambda}(t)$ and using again equation (3.1) we get:

$$\dot{\underline{\lambda}}(t) = \mathbf{P} \dot{\underline{x}}(t) = \mathbf{P} (\mathbf{A} \underline{x}(t) + \mathbf{B} \underline{u}(t)) = \mathbf{P} \mathbf{A} \underline{x}(t) + \mathbf{P} \mathbf{B} \underline{u}(t) \quad (3.16)$$

Then using the expression of control $\underline{u}(t)$ provided in (3.12) as well as (3.15) we get:

$$\begin{aligned} \dot{\underline{\lambda}}(t) &= \mathbf{P} \mathbf{A} \underline{x}(t) - \mathbf{P} \mathbf{B} \mathbf{R}^{-1} \mathbf{B}^T \underline{\lambda}(t) \\ &= \mathbf{P} \mathbf{A} \underline{x}(t) - \mathbf{P} \mathbf{B} \mathbf{R}^{-1} \mathbf{B}^T \mathbf{P} \underline{x}(t) \end{aligned} \quad (3.17)$$

Finally using (3.17) within (3.14) and using $\underline{\lambda}(t) = \mathbf{P} \underline{x}(t)$ (see (3.15)) we get:

$$\begin{aligned} -\mathbf{P} \mathbf{A} \underline{x}(t) + \mathbf{P} \mathbf{B} \mathbf{R}^{-1} \mathbf{B}^T \mathbf{P} \underline{x}(t) &= \mathbf{Q} \underline{x}(t) + \mathbf{A}^T \mathbf{P} \underline{x}(t) \\ \Leftrightarrow (\mathbf{A}^T \mathbf{P} + \mathbf{P} \mathbf{A} - \mathbf{P} \mathbf{B} \mathbf{R}^{-1} \mathbf{B}^T \mathbf{P} + \mathbf{Q}) \underline{x}(t) &= \underline{0} \end{aligned} \quad (3.18)$$

As far as this equality stands for every value of the state vector $\underline{x}(t)$ we retrieve the algebraic Riccati equation (3.7):

$$\mathbf{A}^T \mathbf{P} + \mathbf{P} \mathbf{A} - \mathbf{P} \mathbf{B} \mathbf{R}^{-1} \mathbf{B}^T \mathbf{P} + \mathbf{Q} = \mathbf{0} \quad (3.19)$$

3.4 Extension to nonlinear system affine in control

We consider the following infinite horizon optimal control problem consisting in finding the control \underline{u} that minimizes the following performance index where $q(\underline{x})$ is positive semi-definite:

$$J(\underline{u}(t)) = \frac{1}{2} \int_0^\infty (q(\underline{x}) + \underline{u}^T \underline{u}) dt \quad (3.20)$$

under the *constraint* that the system is nonlinear but affine in control:

$$\begin{cases} \dot{\underline{x}} = \underline{f}(\underline{x}) + \underline{g}(\underline{x}) \underline{u} \\ \underline{x}(0) = \underline{x}_0 \end{cases} \quad (3.21)$$

We assume that vector field \underline{f} is such that $\underline{f}(\underline{x}) = \underline{0}$. Thus $(\underline{x}_e := \underline{0}, \underline{u}_e := \underline{0})$ is an equilibrium point for the nonlinear system affine in control. Consequently $\underline{f}(\underline{x}) = \underline{\mathbf{F}}(\underline{x}) \underline{x}$ for some, possibly not unique, continuous function $\underline{\mathbf{F}} : \mathbb{R}^n \rightarrow \mathbb{R}^{n \times n}$. The classical optimal control design methodology relies on the solution of the Hamilton-Jacobi-Bellman (HJB) equation (1.66):

$$0 = \min_{\underline{u}(t) \in \mathcal{U}} \left(\frac{1}{2} (q(\underline{x}) + \underline{u}^T \underline{u}) + \frac{\partial J^*(\underline{x})}{\partial \underline{x}} (\underline{f}(\underline{x}) + \underline{g}(\underline{x}) \underline{u}) \right) \quad (3.22)$$

Assuming no constraint, the minimum of the preceding Hamilton-Jacobi-Bellman (HJB) equation with respect to \underline{u} is attained for optimal control $\underline{u}^*(t)$ defined by:

$$\underline{u}^*(t) = -\underline{g}^T(\underline{x}) \left(\frac{\partial J^*(\underline{x})}{\partial \underline{x}} \right)^T \quad (3.23)$$

Then replacing \underline{u} by $\underline{u}^* = -\underline{g}^T(\underline{x}) \left(\frac{\partial J^*(\underline{x})}{\partial \underline{x}} \right)^T$, the Hamilton-Jacobi-Bellman (HJB) equation reads:

$$\begin{aligned} 0 &= \frac{1}{2} \left(q(\underline{x}) + \left(\frac{\partial J^*(\underline{x})}{\partial \underline{x}} \right) \underline{g}(\underline{x}) \underline{g}^T(\underline{x}) \left(\frac{\partial J^*(\underline{x})}{\partial \underline{x}} \right)^T \right) \\ &\quad + \frac{\partial J^*(\underline{x})}{\partial \underline{x}} \left(\underline{f}(\underline{x}) - \underline{g}(\underline{x}) \underline{g}^T(\underline{x}) \left(\frac{\partial J^*(\underline{x})}{\partial \underline{x}} \right)^T \right) \end{aligned} \quad (3.24)$$

We finally get:

$$\frac{1}{2} q(\underline{x}) + \frac{\partial J^*(\underline{x})}{\partial \underline{x}} \underline{f}(\underline{x}) - \frac{1}{2} \left(\frac{\partial J^*(\underline{x})}{\partial \underline{x}} \right) \underline{g}(\underline{x}) \underline{g}^T(\underline{x}) \left(\frac{\partial J^*(\underline{x})}{\partial \underline{x}} \right)^T = 0 \quad (3.25)$$

In the linearized case the solution of the optimal control problem is a linear static state feedback of the form $\underline{u} = -\underline{\mathbf{B}}^T \bar{\mathbf{P}}$, where $\bar{\mathbf{P}}$ is the symmetric positive definite solution of the algebraic Riccati equation:

$$\underline{\mathbf{A}}^T \bar{\mathbf{P}} + \bar{\mathbf{P}} \underline{\mathbf{A}} - \bar{\mathbf{P}} \underline{\mathbf{B}} \underline{\mathbf{B}}^T \bar{\mathbf{P}} + \underline{\mathbf{Q}} = \underline{\mathbf{0}} \quad (3.26)$$

where:

$$\begin{cases} \mathbf{A} = \frac{\partial f(\underline{x})}{\partial \underline{x}} \Big|_{\underline{x}=\underline{0}} \\ \mathbf{B} = \underline{g}(\underline{0}) \\ \mathbf{Q} = \frac{1}{2} \frac{\partial^2 q(\underline{x})}{\partial \underline{x}^2} \Big|_{\underline{x}=\underline{0}} \end{cases} \quad (3.27)$$

Following Sassano and Astolfi¹, there exists a matrix $\mathbf{R} = \mathbf{R}^T > 0$, a neighbourhood of the origin $\Omega \subseteq \mathbb{R}^{2n}$ and $\bar{k} \geq 0$ such that for all $k \geq \bar{k}$ the function $V(\underline{x}, \underline{\xi})$ is positive definite and satisfies the following partial differential inequality:

$$\frac{1}{2}q(\underline{x}) + V_{\underline{x}}(\underline{x}, \underline{\xi})\underline{f}(\underline{x}) + V_{\underline{\xi}}(\underline{x}, \underline{\xi})\dot{\underline{\xi}} - \frac{1}{2}V_{\underline{x}}(\underline{x}, \underline{\xi})\underline{g}(\underline{x})\underline{g}^T(\underline{x})V_{\underline{x}}^T(\underline{x}, \underline{\xi}) \leq 0 \quad (3.28)$$

where:

$$\begin{cases} V(\underline{x}, \underline{\xi}) = P(\underline{\xi})\underline{x} + \frac{1}{2}(\underline{x} - \underline{\xi})^T \mathbf{R}(\underline{x} - \underline{\xi}) \\ \dot{\underline{\xi}} = -k V_{\underline{\xi}}^T(\underline{x}, \underline{\xi}) \quad \forall (\underline{x}, \underline{\xi}) \in \Omega \end{cases} \quad (3.29)$$

The \mathcal{C}^1 mapping $P : \mathbb{R}^n \rightarrow \mathbb{R}^{1 \times n}$, $P(\underline{0}) = \underline{0}^T$, is defined as follows:

$$\frac{1}{2}q(\underline{x}) + P(\underline{x})\underline{f}(\underline{x}) - \frac{1}{2}P(\underline{x})\underline{g}(\underline{x})\underline{g}^T(\underline{x})P(\underline{x})^T + \sigma(\underline{x}) = 0 \quad (3.30)$$

where $\sigma(\underline{x}) = \underline{x}^T \Sigma(\underline{x})\underline{x}$ with $\Sigma : \mathbb{R}^n \rightarrow \mathbb{R}^{n \times n}$, $\Sigma(\underline{0}) = \underline{0}$.

Furthermore $P(\underline{x})$ is tangent at $\underline{x} = \underline{0}$ to $\bar{\mathbf{P}}$:

$$\frac{\partial P(\underline{x})^T}{\partial \underline{x}} \Big|_{\underline{x}=\underline{0}} = \bar{\mathbf{P}} \quad (3.31)$$

Since $P(\underline{x})$ is tangent at $\underline{x} = \underline{0}$ to the solution $\bar{\mathbf{P}}$ of the algebraic Riccati equation, the function $P(\underline{x})\underline{x} : \mathbb{R}^n \rightarrow \mathbb{R}$ is locally quadratic around the origin and moreover has a local minimum for $\underline{x} = \underline{0}$.

Let $\Psi(\underline{\xi})$ be Jacobian matrix of the mapping $P(\underline{\xi})$ and $\Phi : \mathbb{R}^n \times \mathbb{R}^n \rightarrow \mathbb{R}^{n \times n}$ a continuous matrix valued function such that:

$$\begin{cases} P(\underline{\xi}) = \underline{\xi}^T \Psi(\underline{\xi})^T \\ P(\underline{x}) - P(\underline{\xi}) = (\underline{x} - \underline{\xi})^T \Phi(\underline{x}, \underline{\xi})^T \end{cases} \quad (3.32)$$

Then the approximate regional dynamic optimal control is found to be¹:

$$\begin{aligned} \underline{u} &= -\underline{g}(\underline{x})^T V_{\underline{x}}^T(\underline{x}, \underline{\xi}) \\ &= -\underline{g}(\underline{x})^T (P(\underline{\xi})^T + \mathbf{R}(\underline{x} - \underline{\xi})) \\ &= -\underline{g}(\underline{x})^T (P(\underline{x})^T + \mathbf{R}(\underline{x} - \underline{\xi}) - (P(\underline{x})^T - P(\underline{\xi})^T)) \\ &= -\underline{g}(\underline{x})^T (P(\underline{x})^T + (\mathbf{R} - \Phi(\underline{x}, \underline{\xi}))(\underline{x} - \underline{\xi})) \end{aligned} \quad (3.33)$$

where:

$$\dot{\underline{\xi}} = -k V_{\underline{\xi}}^T(\underline{x}, \underline{\xi}) = -k (\Psi(\underline{\xi})^T \underline{x} - \mathbf{R}(\underline{x} - \underline{\xi})) \quad (3.34)$$

Such control has been applied to internal combustion engine test benches².

¹Sassano M. and Astolfi A, Dynamic approximate solutions of the HJ inequality and of the HJB equation for input-affine nonlinear systems. IEEE Transactions on Automatic Control, 57(10):2490–2503, 2012.

²Passenbrunner T., Sassano M., del Re L., Optimal Control with Input Constraints applied to Internal Combustion Engine Test Benches, 9th IFAC Symposium on Nonlinear Control Systems, September 4-6, 2013. Toulouse, France

3.5 Solution of the algebraic Riccati equation

3.5.1 Hamiltonian matrix based solution

It can be shown that if the pair (\mathbf{A}, \mathbf{B}) is stabilizable and the pair (\mathbf{A}, \mathbf{N}) is detectable, with $\mathbf{Q} = \mathbf{N}^T \mathbf{N}$ positive semi-definite and \mathbf{R} positive definite, then \mathbf{P} is a the unique positive semi-definite (symmetric) solution of the *algebraic Riccati equation* (ARE) (3.7).

Combining (3.13) and (3.14) into a single state equation yields:

$$\begin{bmatrix} \dot{\underline{x}}(t) \\ \dot{\underline{\lambda}}(t) \end{bmatrix} = \begin{bmatrix} \mathbf{A} & -\mathbf{B}\mathbf{R}^{-1}\mathbf{B}^T \\ -\mathbf{Q} & -\mathbf{A}^T \end{bmatrix} \begin{bmatrix} \underline{x}(t) \\ \underline{\lambda}(t) \end{bmatrix} = \mathbf{H} \begin{bmatrix} \underline{x}(t) \\ \underline{\lambda}(t) \end{bmatrix} \quad (3.35)$$

We have seen that the following $2n \times 2n$ matrix \mathbf{H} is called the Hamiltonian matrix:

$$\mathbf{H} = \begin{bmatrix} \mathbf{A} & -\mathbf{B}\mathbf{R}^{-1}\mathbf{B}^T \\ -\mathbf{Q} & -\mathbf{A}^T \end{bmatrix} \quad (3.36)$$

It can be shown that the Hamiltonian matrix \mathbf{H} has n eigenvalues in the open left half plane and n eigenvalues in the open right half plane. The eigenvalues are symmetric with respects to the imaginary axis: if $\underline{\lambda}$ is and eigenvalue of \mathbf{H} then $-\underline{\lambda}$ is also an eigenvalue of \mathbf{H} . In addition \mathbf{H} has no pure imaginary eigenvalues.

Furthermore if the $2n \times n$ matrix $\begin{bmatrix} \mathbf{X}_1 \\ \mathbf{X}_2 \end{bmatrix}$ has columns that comprise all the eigenvectors associated with the n eigenvalues in the *open left half plane* then \mathbf{X}_1 is invertible and the positive semi-definite solution of the *algebraic Riccati equation* (ARE) is:

$$\mathbf{P} = \mathbf{X}_2 \mathbf{X}_1^{-1} \quad (3.37)$$

Similarly the negative semi-definite solution of the *algebraic Riccati equation* (ARE) is build thanks to the eigenvectors associated with the n eigenvalues in the open right half plane (i.e. the unstable invariant subspace). Once again the solution of the optimal control problem only retains the positive semi-definite solution of the *algebraic Riccati equation*.

In addition it can be shown that the eigenvalues of $\mathbf{A} - \mathbf{B}\mathbf{K}$ where $\mathbf{K} = \mathbf{R}^{-1}\mathbf{B}^T\mathbf{P}$ (that are the eigenvalues of the closed loop plant) are equal to the n eigenvalues in the open left half plane of the Hamiltonian matrix \mathbf{H} .

3.5.2 Proof of the results on the the Hamiltonian matrix

To proof that \mathbf{H} has n eigenvalues in the open left half plane and n eigenvalues in the open right half plane which are symmetric with respects to the imaginary axis we define:

$$\mathbf{J} = \begin{bmatrix} \mathbf{0} & \mathbb{I} \\ -\mathbb{I} & \mathbf{0} \end{bmatrix} \quad (3.38)$$

Matrix \mathbf{J} as the following properties:

$$\mathbf{J}\mathbf{J}^T = \begin{bmatrix} \mathbb{I} & \mathbf{0} \\ \mathbf{0} & \mathbb{I} \end{bmatrix} \quad \text{and} \quad \mathbf{J}^T\mathbf{J} = -\begin{bmatrix} \mathbb{I} & \mathbf{0} \\ \mathbf{0} & \mathbb{I} \end{bmatrix} \quad (3.39)$$

In addition, as far as matrices \mathbf{S} and \mathbf{Q} within Hamiltonian matrix \mathbf{H} are symmetric matrices, it can be easily verified that:

$$\mathbf{H}\mathbf{J} = (\mathbf{H}\mathbf{J})^T \Rightarrow \mathbf{J}^T\mathbf{H}\mathbf{J} = \mathbf{J}^T\mathbf{J}^T\mathbf{H}^T = -\mathbf{H}^T \quad (3.40)$$

Let $\underline{\lambda}$ be an eigenvalue of Hamiltonian matrix \mathbf{H} associated with eigenvector \underline{x} . We get:

$$\begin{aligned} \mathbf{H}\underline{x} &= \underline{\lambda}\underline{x} \\ \Rightarrow \mathbf{H}\mathbf{J}\mathbf{J}^T\underline{x} &= \underline{\lambda}\underline{x} \\ \Rightarrow \mathbf{J}^T\mathbf{H}\mathbf{J}\mathbf{J}^T\underline{x} &= \underline{\lambda}\mathbf{J}^T\underline{x} \\ \Leftrightarrow -\mathbf{H}^T\mathbf{J}^T\underline{x} &= \underline{\lambda}\mathbf{J}^T\underline{x} \\ \Leftrightarrow \mathbf{H}^T\mathbf{J}^T\underline{x} &= -\underline{\lambda}\mathbf{J}^T\underline{x} \end{aligned} \quad (3.41)$$

Thus $-\underline{\lambda}$ is an eigenvalue of \mathbf{H}^T with the corresponding eigenvector $\mathbf{J}^T\underline{x}$. Using the fact that $\det(\mathbf{M}) = \det(\mathbf{M}^T)$ we get:

$$\det(-\underline{\lambda}\mathbb{I} - \mathbf{H}^T) = \det((-\underline{\lambda}\mathbb{I} - \mathbf{H})^T) \quad (3.42)$$

As a consequence we conclude that $-\underline{\lambda}$ is also an eigenvalue of \mathbf{H} . To show that \mathbf{H} has no imaginary eigenvalues suppose:

$$\mathbf{H} \begin{bmatrix} \underline{x}_1 \\ \underline{x}_2 \end{bmatrix} = \begin{bmatrix} \mathbf{A} & -\mathbf{B}\mathbf{R}^{-1}\mathbf{B}^T \\ -\mathbf{Q} & -\mathbf{A}^T \end{bmatrix} \begin{bmatrix} \underline{x}_1 \\ \underline{x}_2 \end{bmatrix} = \underline{\lambda} \begin{bmatrix} \underline{x}_1 \\ \underline{x}_2 \end{bmatrix} \quad (3.43)$$

Where \underline{x}_1 and \underline{x}_2 are *not* both zero and

$$\underline{\lambda} + \underline{\lambda}^* = 0 \quad (3.44)$$

where $\underline{\lambda}^*$ stands for the complex conjugate of $\underline{\lambda}$. We seek a contradiction. Let's denote by \underline{x}^* the transpose conjugate of vector \underline{x} .

– Equation (3.43) gives:

$$\mathbf{A}\underline{x}_1 - \mathbf{B}\mathbf{R}^{-1}\mathbf{B}^T\underline{x}_2 = \underline{\lambda}\underline{x}_1 \Rightarrow \underline{x}_2^*\mathbf{B}\mathbf{R}^{-1}\mathbf{B}^T\underline{x}_2 = \underline{x}_2^*\mathbf{A}\underline{x}_1 - \underline{\lambda}\underline{x}_2^*\underline{x}_1 \quad (3.45)$$

– Taking into account that \mathbf{Q} is a real symmetric matrix, equation (3.43) also gives:

$$-\mathbf{Q}\underline{x}_1 - \mathbf{A}^T\underline{x}_2 = \underline{\lambda}\underline{x}_2 \Rightarrow \underline{\lambda}\underline{x}_2^T = -\underline{x}_1^T\mathbf{Q} - \underline{x}_2^T\mathbf{A} \Rightarrow \underline{\lambda}^*\underline{x}_2^* = -\underline{x}_1^*\mathbf{Q} - \underline{x}_2^*\mathbf{A} \quad (3.46)$$

Denoting $\mathbf{M} = \mathbf{B}\mathbf{R}^{-1}\mathbf{B}^T$ and taking into account (3.46) into (3.45) yields:

$$\begin{cases} \underline{x}_2^*\mathbf{B}\mathbf{R}^{-1}\mathbf{B}^T\underline{x}_2 = \underline{x}_2^*\mathbf{A}\underline{x}_1 - \underline{\lambda}\underline{x}_2^*\underline{x}_1 \\ \underline{x}_2^*\mathbf{A} = -\underline{x}_1^*\mathbf{Q} - \underline{\lambda}^*\underline{x}_2^* \end{cases} \quad (3.47)$$

$$\Rightarrow \underline{x}_2^*\mathbf{M}\underline{x}_2 = -\underline{x}_1^*\mathbf{Q}\underline{x}_1 - \underline{\lambda}^*\underline{x}_2^*\underline{x}_1 - \underline{\lambda}\underline{x}_2^*\underline{x}_1 = -\underline{x}_1^*\mathbf{Q}\underline{x}_1 - (\underline{\lambda}^* + \underline{\lambda})\underline{x}_2^*\underline{x}_1$$

Using (3.44) we finally get:

$$\underline{x}_2^*\mathbf{M}\underline{x}_2 = -\underline{x}_1^*\mathbf{Q}\underline{x}_1 \quad (3.48)$$

Since \mathbf{R} and \mathbf{Q} are positive semi-definite matrices, and consequently also $\mathbf{M} = \mathbf{B}\mathbf{R}^{-1}\mathbf{B}^T$, this implies:

$$\begin{cases} \mathbf{M}\underline{x}_2 = \underline{0} \\ \mathbf{Q}\underline{x}_1 = \underline{0} \end{cases} \quad (3.49)$$

Then using (3.45) we get:

$$\begin{cases} \mathbf{A}\underline{x}_1 = \lambda \underline{x}_1 \\ \mathbf{Q}\underline{x}_1 = \underline{0} \end{cases} \Rightarrow \begin{bmatrix} \mathbf{A} - \lambda \mathbb{I} \\ \mathbf{Q} \end{bmatrix} \underline{x}_1 = \underline{0} \quad (3.50)$$

If $\underline{x}_1 \neq \underline{0}$ then this contradicts observability of the pair (\mathbf{Q}, \mathbf{A}) by the Popov-Belevitch-Hautus test. Similarly if $\underline{x}_2 \neq \underline{0}$ then $\underline{x}_2^* [\mathbf{M} \ \mathbf{A} + \lambda^* \mathbb{I}] = \underline{0}$ which contradicts the observability of the pair (\mathbf{A}, \mathbf{M}) .

3.5.3 Solving general algebraic Riccati and Lyapunov equations

The general algebraic Riccati equation reads as follows where all matrices are square of dimension $n \times n$:

$$\mathbf{A}\mathbf{X} + \mathbf{X}\mathbf{B} + \mathbf{C} + \mathbf{X}\mathbf{D}\mathbf{X} = \mathbf{0} \quad (3.51)$$

Matrices \mathbf{A} , \mathbf{B} , \mathbf{C} and \mathbf{D} are known whereas matrix \mathbf{X} has to be determined.

The general algebraic Lyapunov equation is obtained as a special case of the algebraic Riccati by setting $\mathbf{D} = \mathbf{0}$.

The general algebraic Riccati equation can be solved³ by considering the following $2n \times 2n$ matrix \mathbf{H} :

$$\mathbf{H} = \begin{bmatrix} \mathbf{B} & \mathbf{D} \\ -\mathbf{C} & -\mathbf{A} \end{bmatrix} \quad (3.52)$$

Let the eigenvalues of matrix \mathbf{H} be denoted λ_i , $i = 1, \dots, 2n$, and the corresponding eigenvectors be denoted \underline{v}_i . Furthermore let \mathbf{M} be the $2n \times 2n$ matrix composed of all real eigenvectors of matrix \mathbf{H} ; for complex conjugate eigenvectors, the corresponding columns of matrix \mathbf{M} are changed into the real and imaginary parts of such eigenvectors. Note that there are many ways to form matrix \mathbf{M} .

Then we can write the following relationship:

$$\mathbf{H}\mathbf{M} = \mathbf{M}\mathbf{\Lambda} = \begin{bmatrix} \mathbf{M}_1 & \mathbf{M}_2 \end{bmatrix} \begin{bmatrix} \mathbf{\Lambda}_1 & \mathbf{0} \\ \mathbf{0} & \mathbf{\Lambda}_2 \end{bmatrix} \quad (3.53)$$

Matrix \mathbf{M}_1 contains the n first columns of \mathbf{M} whereas matrix \mathbf{M}_2 contains the n last columns of \mathbf{M} .

Matrices $\mathbf{\Lambda}_1$ and $\mathbf{\Lambda}_2$ are diagonal matrices formed by the eigenvalues of \mathbf{H} as soon as there are distinct; for eigenvalues with multiplicity greater than 1, the corresponding part in matrix $\mathbf{\Lambda}$ represents the Jordan form.

Thus we have:

$$\begin{cases} \mathbf{H}\mathbf{M}_1 = \mathbf{M}_1\mathbf{\Lambda}_1 \\ \mathbf{H}\mathbf{M}_2 = \mathbf{M}_2\mathbf{\Lambda}_2 \end{cases} \quad (3.54)$$

We will focus our attention on the first equation and split matrix \mathbf{M}_1 as follows:

$$\mathbf{M}_1 = \begin{bmatrix} \mathbf{M}_{11} \\ \mathbf{M}_{12} \end{bmatrix} \quad (3.55)$$

³Optimal Control of Singularly Perturbed Linear Systems with Applications: High Accuracy Techniques, Z. Gajic and M. Lim, Marcel Dekker, New York, 2001

Using the expression of \mathbf{H} in (3.52), the relationship $\mathbf{H}\mathbf{M}_1 = \mathbf{M}_1\boldsymbol{\Lambda}_1$ reads as follows:

$$\mathbf{H}\mathbf{M}_1 = \mathbf{M}_1\boldsymbol{\Lambda}_1 \Rightarrow \begin{cases} \mathbf{B}\mathbf{M}_{11} + \mathbf{D}\mathbf{M}_{12} = \mathbf{M}_{11}\boldsymbol{\Lambda}_1 \\ -\mathbf{C}\mathbf{M}_{11} - \mathbf{A}\mathbf{M}_{12} = \mathbf{M}_{12}\boldsymbol{\Lambda}_1 \end{cases} \quad (3.56)$$

Assuming that matrix \mathbf{M}_{11} is not singular, we can check that a solution \mathbf{X} of the general algebraic Riccati equation (3.51) reads:

$$\mathbf{X} = \mathbf{M}_{12}\mathbf{M}_{11}^{-1} \quad (3.57)$$

Indeed:

$$\begin{aligned} \begin{cases} \mathbf{B}\mathbf{M}_{11} + \mathbf{D}\mathbf{M}_{12} = \mathbf{M}_{11}\boldsymbol{\Lambda}_1 \\ \mathbf{C}\mathbf{M}_{11} + \mathbf{A}\mathbf{M}_{12} = -\mathbf{M}_{12}\boldsymbol{\Lambda}_1 \\ \mathbf{X} = \mathbf{M}_{12}\mathbf{M}_{11}^{-1} \end{cases} \\ \Rightarrow \mathbf{A}\mathbf{X} + \mathbf{X}\mathbf{B} + \mathbf{C} + \mathbf{X}\mathbf{D}\mathbf{X} &= \mathbf{A}\mathbf{M}_{12}\mathbf{M}_{11}^{-1} + \mathbf{M}_{12}\mathbf{M}_{11}^{-1}\mathbf{B} + \mathbf{C} \\ &\quad + \mathbf{M}_{12}\mathbf{M}_{11}^{-1}\mathbf{D}\mathbf{M}_{12}\mathbf{M}_{11}^{-1} \\ &= (\mathbf{A}\mathbf{M}_{12} + \mathbf{C}\mathbf{M}_{11})\mathbf{M}_{11}^{-1} \\ &\quad + \mathbf{M}_{12}\mathbf{M}_{11}^{-1}(\mathbf{B}\mathbf{M}_{11} + \mathbf{D}\mathbf{M}_{12})\mathbf{M}_{11}^{-1} \\ &= -\mathbf{M}_{12}\boldsymbol{\Lambda}_1\mathbf{M}_{11}^{-1} + \mathbf{M}_{12}\mathbf{M}_{11}^{-1}\mathbf{M}_{11}\boldsymbol{\Lambda}_1\mathbf{M}_{11}^{-1} \\ &= \mathbf{0} \end{aligned} \quad (3.58)$$

It is worth noticing that each selection of eigenvectors within matrix \mathbf{M}_1 leads to a new solution of the general algebraic Riccati equation (3.51). Consequently the solution to the general algebraic Riccati equation (3.51) is not unique. The same statement holds for different choice of matrix \mathbf{M}_2 and the corresponding solution of (3.51) obtained from $\mathbf{X} = \mathbf{M}_{21}\mathbf{M}_{22}^{-1}$.

3.6 Eigenvalues of full-state feedback control

Let's consider a linear plant controlled through a state feedback as follows:

$$\begin{cases} \dot{\underline{x}}(t) = \mathbf{A}\underline{x}(t) + \mathbf{B}\underline{u}(t) \\ \underline{u}(t) = -\mathbf{K}\underline{x}(t) + \underline{r}(t) \end{cases} \quad (3.59)$$

The dynamics of the closed loop system reads:

$$\dot{\underline{x}}(t) = (\mathbf{A} - \mathbf{B}\mathbf{K})\underline{x}(t) + \mathbf{B}\underline{r}(t) \quad (3.60)$$

We will assume the following equation between the state $\underline{x}(t)$ and the *controlled* output $\underline{z}(t)$:

$$\underline{z}(t) = \mathbf{N}\underline{x}(t) \quad (3.61)$$

Let $\Phi(s)$ be the matrix defined by:

$$\Phi(s) = (s\mathbb{I} - \mathbf{A})^{-1} \quad (3.62)$$

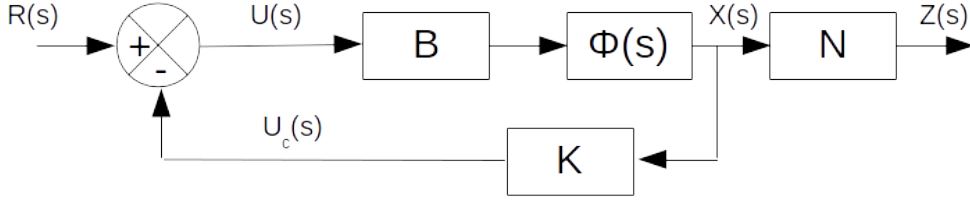

Figure 3.1: Full-state feedback control

In order to compute the closed loop transfer matrix between $\underline{Z}(s)$ and $\underline{R}(s)$ we will first compute $\underline{X}(s)$ as a function of $\underline{R}(s)$. When we take the Laplace transform of (3.59) and assuming no initial condition we have:

$$\begin{aligned} s\underline{X}(s) &= \mathbf{A}\underline{X}(s) + \mathbf{B}(-\mathbf{K}\underline{X}(s) + \underline{R}(s)) \\ \Rightarrow \underline{X}(s)(s\mathbb{I} - \mathbf{A} + \mathbf{BK}) &= \mathbf{B}\underline{R}(s) \\ \Rightarrow \underline{X}(s) &= (s\mathbb{I} - \mathbf{A} + \mathbf{BK})^{-1}\mathbf{B}\underline{R}(s) \end{aligned} \quad (3.63)$$

And thus:

$$\underline{Z}(s) = \mathbf{N}\underline{X}(s) = \mathbf{N}(s\mathbb{I} - \mathbf{A} + \mathbf{BK})^{-1}\mathbf{B}\underline{R}(s) \quad (3.64)$$

The block diagram of the state feedback control is shown in Figure 3.59. We get:

$$\begin{aligned} \underline{X}(s) &= \Phi(s)\mathbf{B}(\underline{R}(s) - \mathbf{K}\underline{X}(s)) \\ &= (\mathbb{I} + \Phi(s)\mathbf{BK})^{-1}\Phi(s)\mathbf{B}\underline{R}(s) \end{aligned} \quad (3.65)$$

Using the fact that $(\mathbf{AB})^{-1} = \mathbf{B}^{-1}\mathbf{A}^{-1}$ we get:

$$\begin{aligned} \underline{X}(s) &= (\Phi^{-1}(s)(\mathbb{I} + \Phi(s)\mathbf{BK}))^{-1}\mathbf{B}\underline{R}(s) \\ &= (\Phi^{-1}(s) + \mathbf{BK})^{-1}\mathbf{B}\underline{R}(s) \\ &= (s\mathbb{I} - \mathbf{A} + \mathbf{BK})^{-1}\mathbf{B}\underline{R}(s) \end{aligned} \quad (3.66)$$

Thus, using the equation $\underline{Z}(s) = \mathbf{N}\underline{X}(s)$ we get the same result than (3.64). The open loop characteristic polynomial is given by:

$$\det(s\mathbb{I} - \mathbf{A}) = \det(\Phi^{-1}(s)) \quad (3.67)$$

Whereas the closed loop characteristic polynomial is given by:

$$\det(s\mathbb{I} - \mathbf{A} + \mathbf{BK}) \quad (3.68)$$

We recall the Schur's formula:

$$\begin{aligned} \det \begin{bmatrix} \mathbf{A}_{11} & \mathbf{A}_{12} \\ \mathbf{A}_{21} & \mathbf{A}_{22} \end{bmatrix} &= \det(\mathbf{A}_{22}) \det(\mathbf{A}_{11} - \mathbf{A}_{12}\mathbf{A}_{22}^{-1}\mathbf{A}_{21}) \\ &= \det(\mathbf{A}_{11}) \det(\mathbf{A}_{22} - \mathbf{A}_{21}\mathbf{A}_{11}^{-1}\mathbf{A}_{12}) \end{aligned} \quad (3.69)$$

Setting $\mathbf{A}_{11} = \Phi^{-1}(s)$, $\mathbf{A}_{21} = -\mathbf{K}$, $\mathbf{A}_{12} = \mathbf{B}$ and $\mathbf{A}_{22} = \mathbb{I}$ we get:

$$\begin{aligned}
\det(s\mathbb{I} - \mathbf{A} + \mathbf{BK}) &= \det(\Phi^{-1}(s) + \mathbf{BK}) \\
&= \det \begin{bmatrix} \Phi^{-1}(s) & \mathbf{B} \\ -\mathbf{K} & \mathbb{I} \end{bmatrix} \\
&= \det(\mathbf{A}_{11}) \det(\mathbf{A}_{22} - \mathbf{A}_{21}\mathbf{A}_{11}^{-1}\mathbf{A}_{12}) \\
&= \det(\Phi^{-1}(s)) \det(\mathbb{I} + \mathbf{K}\Phi(s)\mathbf{B}) \\
&= \det(s\mathbb{I} - \mathbf{A}) \det(\mathbb{I} + \mathbf{K}\Phi(s)\mathbf{B})
\end{aligned} \tag{3.70}$$

It is worth noticing that the same result can be obtained by using the following properties of determinant: $\det(\mathbb{I} + \mathbf{M}_1\mathbf{M}_2\mathbf{M}_3) = \det(\mathbb{I} + \mathbf{M}_3\mathbf{M}_1\mathbf{M}_2) = \det(\mathbb{I} + \mathbf{M}_2\mathbf{M}_3\mathbf{M}_1)$ and $\det(\mathbf{M}_1\mathbf{M}_2) = \det(\mathbf{M}_2\mathbf{M}_1)$. Indeed:

$$\begin{aligned}
\det(s\mathbb{I} - \mathbf{A} + \mathbf{BK}) &= \det \left((s\mathbb{I} - \mathbf{A}) \left(\mathbb{I} + (s\mathbb{I} - \mathbf{A})^{-1} \mathbf{BK} \right) \right) \\
&= \det \left((s\mathbb{I} - \mathbf{A}) (\mathbb{I} + \Phi(s)\mathbf{BK}) \right) \\
&= \det(s\mathbb{I} - \mathbf{A}) \det(\mathbb{I} + \Phi(s)\mathbf{BK}) \\
&= \det(s\mathbb{I} - \mathbf{A}) \det(\mathbb{I} + \mathbf{K}\Phi(s)\mathbf{B})
\end{aligned} \tag{3.71}$$

The roots of $\det(s\mathbb{I} - \mathbf{A} + \mathbf{BK})$ are the eigenvalues of the closed loop system. Consequently they are related to the stability of the closed loop system.

Moreover the roots of $\det(\mathbb{I} + \mathbf{K}\Phi(s)\mathbf{B})$ are exactly the roots of $\det(s\mathbb{I} - \mathbf{A} + \mathbf{BK})$. Indeed as far as $\Phi(s) = (s\mathbb{I} - \mathbf{A})^{-1}$ the inverse of $(s\mathbb{I} - \mathbf{A})$ is computed as the adjugate of matrix $(s\mathbb{I} - \mathbf{A})$ divided by $\det(s\mathbb{I} - \mathbf{A})$ which finally simplifies with the denominator of $\det(\mathbb{I} + \mathbf{K}\Phi(s)\mathbf{B})$

$$\begin{aligned}
\det(\mathbb{I} + \mathbf{K}\Phi(s)\mathbf{B}) &= \det \left(\mathbb{I} + \mathbf{K} (s\mathbb{I} - \mathbf{A})^{-1} \mathbf{B} \right) \\
&= \det \left(\mathbb{I} + \mathbf{K} \frac{\text{Adj}(s\mathbb{I} - \mathbf{A})}{\det(s\mathbb{I} - \mathbf{A})} \mathbf{B} \right) \\
&= \det \left(\frac{\det(s\mathbb{I} - \mathbf{A})\mathbb{I} + \mathbf{K} \text{Adj}(s\mathbb{I} - \mathbf{A})\mathbf{B}}{\det(s\mathbb{I} - \mathbf{A})} \right) \\
&= \frac{\det(\det(s\mathbb{I} - \mathbf{A})\mathbb{I} + \mathbf{K} \text{Adj}(s\mathbb{I} - \mathbf{A})\mathbf{B})}{\det(s\mathbb{I} - \mathbf{A})} \\
\Rightarrow \det(s\mathbb{I} - \mathbf{A} + \mathbf{BK}) &= \det(\det(s\mathbb{I} - \mathbf{A})\mathbb{I} + \mathbf{K} \text{Adj}(s\mathbb{I} - \mathbf{A})\mathbf{B})
\end{aligned} \tag{3.72}$$

Thus:

$$\det(\mathbb{I} + \mathbf{K}\Phi(s)\mathbf{B}) = 0 \Leftrightarrow \det(s\mathbb{I} - \mathbf{A} + \mathbf{BK}) = 0 \tag{3.73}$$

3.7 Generalized (MIMO) Nyquist stability criterion

Let's recall the generalized (MIMO) Nyquist stability criterion which will be applied in the next section to the LQR design through Kalman equality.

We remind that the Nyquist plot of $\det(\mathbb{I} + \mathbf{K}\Phi(s)\mathbf{B})$ is the image of $\det(\mathbb{I} + \mathbf{K}\Phi(s)\mathbf{B})$ as s goes clockwise around the Nyquist contour: this includes the entire imaginary axis ($s = j\omega$) and an infinite semi-circle around the right half plane as shown in Figure 3.2.

The generalized (MIMO) Nyquist stability criterion states that the number of unstable closed-loop poles (that are the roots of $\det(s\mathbb{I} - \mathbf{A} + \mathbf{BK})$) is equal to the number of unstable open-loop poles (that are the roots of $\det(s\mathbb{I} - \mathbf{A})$) plus

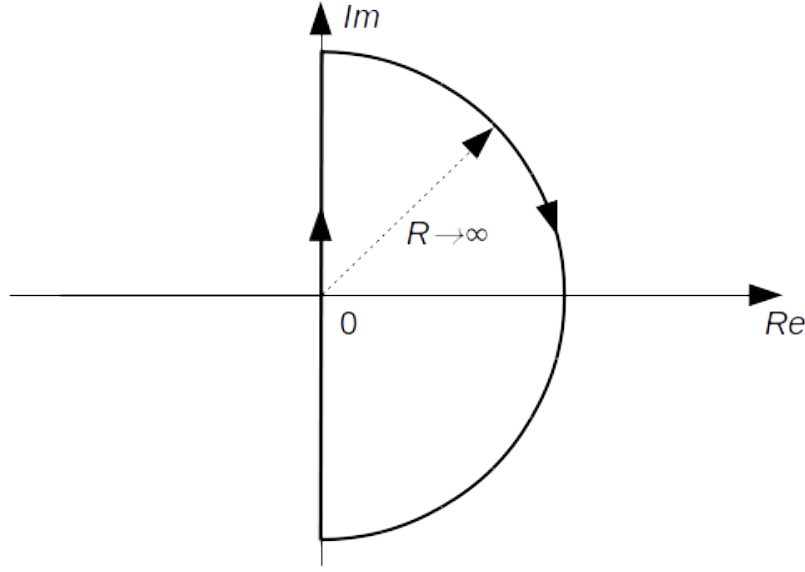

Figure 3.2: Nyquist contour

the number of encirclements of the critical point $(0,0)$ by the Nyquist plot of $\det(\mathbb{I} + \mathbf{K}\Phi(s)\mathbf{B})$; the encirclement is counted positive in the clockwise direction and negative otherwise.

An easy way to determine the number of encirclements of the critical point is to draw a line out from the critical point, in any directions. Then by counting the number of times that the Nyquist plot crosses the line in the clockwise direction (i.e. left to right) and by subtracting the number of times it crosses in the counterclockwise direction then the number of clockwise encirclements of the critical point is obtained. A negative number indicates counterclockwise encirclements.

It is worth noticing that for Single-Input Single-Output (SISO) systems \mathbf{K} is a row vector whereas \mathbf{B} is a column vector. Consequently $\mathbf{K}\Phi(s)\mathbf{B}$ is a scalar and we have:

$$\det(\mathbb{I} + \mathbf{K}\Phi(s)\mathbf{B}) = \det(1 + \mathbf{K}\Phi(s)\mathbf{B}) = 1 + \mathbf{K}\Phi(s)\mathbf{B} \quad (3.74)$$

Thus for Single-Input Single-Output (SISO) systems the number of encirclements of the critical point $(0,0)$ by the Nyquist plot of $\det(\mathbb{I} + \mathbf{K}\Phi(s)\mathbf{B})$ is equivalent to the number of encirclements of the critical point $(-1,0)$ by the Nyquist plot of $\mathbf{K}\Phi(s)\mathbf{B}$.

In the context of output feedback the control $u(t) = -\mathbf{K}\underline{x}(t)$ is replaced by $u(t) = -\mathbf{K}y(t)$ where $y(t)$ is the output of the plant: $y(t) = \mathbf{C}\underline{x}(t)$. As a consequence the control $u(t)$ reads $u(t) = -\mathbf{K}\mathbf{C}\underline{x}(t)$ and state feedback gain \mathbf{K} is replaced by output feedback gain $\mathbf{K}\mathbf{C}$ in equation (3.70):

$$\det(s\mathbb{I} - \mathbf{A} + \mathbf{B}\mathbf{K}\mathbf{C}) = \det(s\mathbb{I} - \mathbf{A}) \det(\mathbb{I} + \mathbf{K}\mathbf{C}\Phi(s)\mathbf{B}) \quad (3.75)$$

This equation involves the transfer function $\mathbf{C}\Phi(s)\mathbf{B}$ between the output

$Y(s)$ and the control $U(s)$ of the plant without any feedback and is used in the Nyquist stability criterion for Single-Input Single-Output (SISO) systems.

It is also worth noticing that $(\mathbb{I} + \mathbf{K}\mathbf{C}\Phi(s)\mathbf{B})^{-1}$ is attached to the so called sensitivity function of the closed loop whereas $\mathbf{C}\Phi(s)\mathbf{B}$ is attached to the open loop transfer function from the process' input $\underline{U}(s)$ to the plant output $\underline{Y}(s)$.

3.8 Kalman equality

Kalman equality reads as follows:

$$(\mathbb{I} + \mathbf{K}\Phi(-s)\mathbf{B})^T \mathbf{R} (\mathbb{I} + \mathbf{K}\Phi(s)\mathbf{B}) = \mathbf{R} + (\Phi(-s)\mathbf{B})^T \mathbf{Q} (\Phi(s)\mathbf{B}) \quad (3.76)$$

The proof of the Kalman equality is provided hereafter. Consider the *algebraic Riccati equation* (3.7):

$$\mathbf{P}\mathbf{A} + \mathbf{A}^T\mathbf{P} - \mathbf{P}\mathbf{B}\mathbf{R}^{-1}\mathbf{B}^T\mathbf{P} + \mathbf{Q} = \mathbf{0} \quad (3.77)$$

Because $\mathbf{K} = \mathbf{R}^{-1}\mathbf{B}^T\mathbf{P}$, $\mathbf{P} = \mathbf{P}^T$ and $\mathbf{R} = \mathbf{R}^T$, the previous equation can be re-written as:

$$\mathbf{P}(s\mathbb{I} - \mathbf{A}) - (-s\mathbb{I} - \mathbf{A})^T\mathbf{P} + \mathbf{K}^T\mathbf{R}\mathbf{K} = \mathbf{Q} \quad (3.78)$$

Using the fact that $\Phi(s) = (s\mathbb{I} - \mathbf{A})^{-1}$ we get:

$$\mathbf{P}\Phi^{-1}(s) + (\Phi^{-1}(-s))^T\mathbf{P} + \mathbf{K}^T\mathbf{R}\mathbf{K} = \mathbf{Q} \quad (3.79)$$

Left multiplying by $\mathbf{B}^T\Phi^T(-s)$ and right multiplying by $\Phi(s)\mathbf{B}$ yields:

$$\begin{aligned} \mathbf{B}^T\Phi^T(-s)\mathbf{P}\mathbf{B} + \mathbf{B}^T\mathbf{P}\Phi(s)\mathbf{B} + \mathbf{B}^T\Phi^T(-s)\mathbf{K}^T\mathbf{R}\mathbf{K}\Phi(s)\mathbf{B} = \\ \mathbf{B}^T\Phi^T(-s)\mathbf{Q}\Phi(s)\mathbf{B} \end{aligned} \quad (3.80)$$

Adding \mathbf{R} to both sides of equation (3.80) as using the fact that $\mathbf{R}\mathbf{K} = \mathbf{B}^T\mathbf{P}$ we get:

$$\begin{aligned} \mathbf{R} + \mathbf{B}^T\Phi^T(-s)\mathbf{K}^T\mathbf{R} + \mathbf{R}\mathbf{K}\Phi(s)\mathbf{B} + \mathbf{B}^T\Phi^T(-s)\mathbf{K}^T\mathbf{R}\mathbf{K}\Phi(s)\mathbf{B} = \\ \mathbf{R} + \mathbf{B}^T\Phi^T(-s)\mathbf{Q}\Phi(s)\mathbf{B} \end{aligned} \quad (3.81)$$

The previous equation can be re-written as:

$$(\mathbb{I} + \mathbf{K}\Phi(-s)\mathbf{B})^T \mathbf{R} (\mathbb{I} + \mathbf{K}\Phi(s)\mathbf{B}) = \mathbf{R} + (\Phi(-s)\mathbf{B})^T \mathbf{Q} (\Phi(s)\mathbf{B}) \quad (3.82)$$

This complete the proof.

3.9 Robustness of Linear Quadratic Regulator

The robustness of the LQR design can be assessed through the Kalman equality (3.76).

We will specialize Kalman equality to the specific case where the plant is a Single Input - Single Output (SISO) system. Then $\mathbf{K}\Phi(s)\mathbf{B}$ and \mathbf{R} are scalars. Setting $\mathbf{Q} = \mathbf{N}^T\mathbf{N}$, Kalman equality (3.76) reduces to:

$$\begin{aligned} \mathbf{Q} &= \mathbf{N}^T\mathbf{N} \\ \Rightarrow (1 + \mathbf{K}\Phi(-s)\mathbf{B})^T (1 + \mathbf{K}\Phi(s)\mathbf{B}) &= 1 + \frac{1}{\mathbf{R}} (\mathbf{N}\Phi(-s)\mathbf{B})^T (\mathbf{N}\Phi(s)\mathbf{B}) \end{aligned} \quad (3.83)$$

Substituting $s = j\omega$ yields:

$$\|1 + \mathbf{K}\Phi(j\omega)\mathbf{B}\|^2 = 1 + \frac{1}{\mathbf{R}} \|\mathbf{N}\Phi(j\omega)\mathbf{B}\|^2 \quad (3.84)$$

Therefore:

$$\|1 + \mathbf{K}\Phi(j\omega)\mathbf{B}\| \geq 1 \quad (3.85)$$

Let's introduce the real part $X(\omega)$ and the imaginary part $Y(\omega)$ of $\mathbf{K}\Phi(j\omega)\mathbf{B}$:

$$\mathbf{K}\Phi(j\omega)\mathbf{B} = X(\omega) + jY(\omega) \quad (3.86)$$

Then $\|1 + \mathbf{K}\Phi(j\omega)\mathbf{B}\|^2$ reads as follows:

$$\|1 + \mathbf{K}\Phi(j\omega)\mathbf{B}\|^2 = \|1 + X(\omega) + jY(\omega)\|^2 = (1 + X(\omega))^2 + Y(\omega)^2 \quad (3.87)$$

Consequently inequality (3.85) reads as follows:

$$\begin{aligned} \|1 + \mathbf{K}\Phi(j\omega)\mathbf{B}\| &\geq 1 \\ \Leftrightarrow \|1 + \mathbf{K}\Phi(j\omega)\mathbf{B}\|^2 &\geq 1 \\ \Leftrightarrow (1 + X(\omega))^2 + Y(\omega)^2 &\geq 1 \end{aligned} \quad (3.88)$$

As a consequence, the Nyquist plot of $\mathbf{K}\Phi(j\omega)\mathbf{B}$ will be outside the circle of unit radius centered at $(-1, 0)$. Thus applying the generalized (MIMO) Nyquist stability criterion and knowing that the LQR design always leads to a stable closed loop plant, the implications of Kalman inequality are the following:

- If the open-loop system has no unstable pole, then the Nyquist plot of $\mathbf{K}\Phi(j\omega)\mathbf{B}$ does not encircle the critical point $(-1, 0)$. This corresponds to a positive gain margin of $+\infty$ as depicted as depicted in Figure 3.3.
- On the other hand if $\Phi(s)$ has unstable poles, the Nyquist plot of $\mathbf{K}\Phi(j\omega)\mathbf{B}$ encircles the critical point $(-1, 0)$ a number on times which corresponds to the number of unstable open loop poles. This corresponds to a negative gain margin which is always lower or equal to $20 \log_{10}(0.5) = -6 \text{ dB}$ as depicted in Figure 3.4.
- In both situations, if the process' phase increases by 60 degrees its Nyquist plots rotates by 60 degrees but the number of encirclements still does not change. Thus the LQR design always leads to a phase margin which is always greater or equal to 60 degrees.

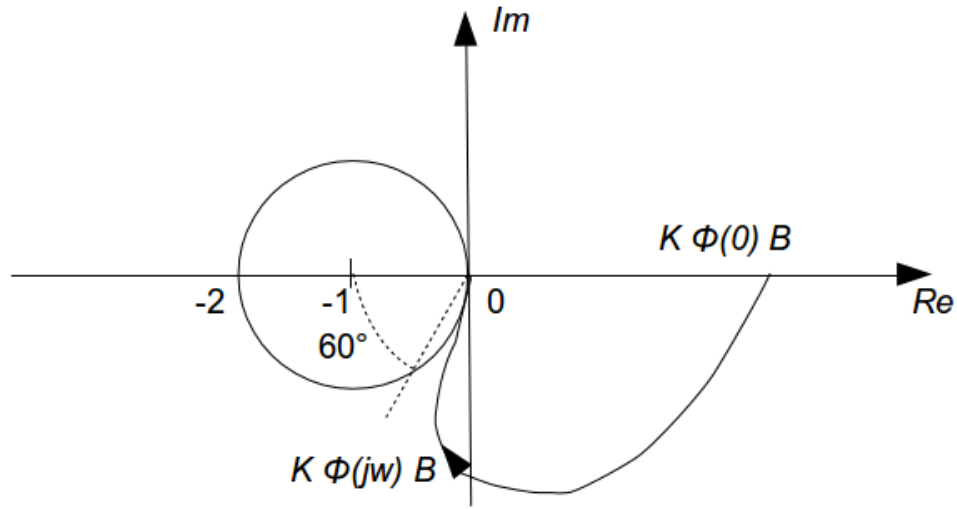

Figure 3.3: Nyquist plot of $\mathbf{K}\Phi(s)\mathbf{B}$: example where the open-loop system has no unstable pole

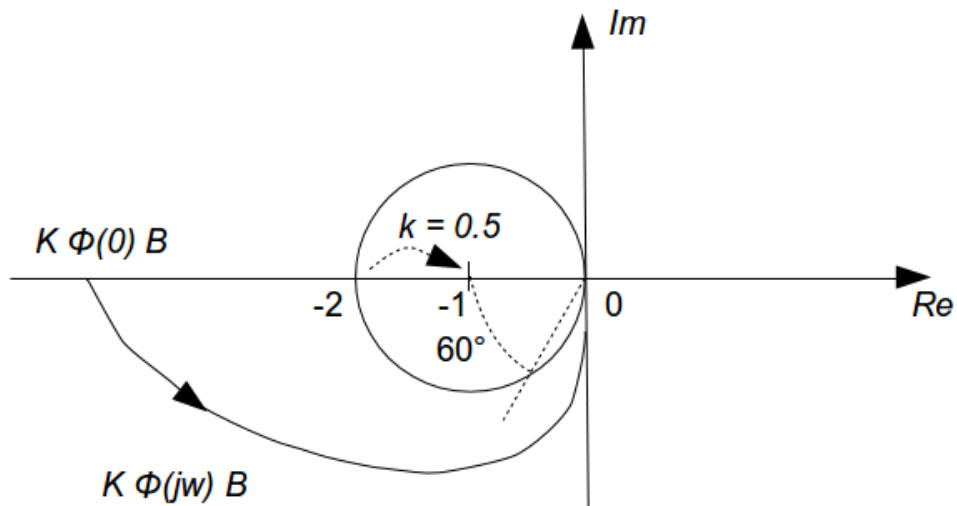

Figure 3.4: Nyquist plot of $\mathbf{K}\Phi(s)\mathbf{B}$: example where the open-loop system has unstable poles

Last but not least, it can be seen in Figure 3.3 and Figure 3.4 that at high-frequency the open-loop gain $\mathbf{K}\Phi(j\omega)\mathbf{B}$ can have at most -90 degrees phase for high-frequencies and therefore the *roll-off* rate is at most -20 dB/decade.

Unfortunately those nice properties are lost as soon as the performance index $J(\underline{u}(t))$ contains state / control cross terms ⁴:

$$J(\underline{u}(t)) = \frac{1}{2} \int_0^{t_f} \underline{x}^T(t) \mathbf{Q} \underline{x}(t) + \underline{u}^T(t) \mathbf{R} \underline{u}(t) + 2 \underline{x}^T(t) \mathbf{S} \underline{u}(t) dt \quad (3.89)$$

This is especially the case for LQG (Linear Quadratic Gaussian) regulator where the plant dynamics as well as the output measurement are subject to stochastic disturbances and where a state estimator has to be used.

3.10 Discrete time LQ regulator

3.10.1 Finite horizon LQ regulator

There is an equivalent theory for discrete time systems. Indeed, for the system:

$$\begin{cases} \underline{x}(k+1) = \mathbf{A} \underline{x}(k) + \mathbf{B} \underline{u}(k) \\ \underline{x}(0) = \underline{x}_0 \end{cases} \quad (3.90)$$

with an equivalent performance criteria:

$$J(\underline{u}(k)) = \frac{1}{2} \underline{x}^T(N) \mathbf{S} \underline{x}(N) + \frac{1}{2} \sum_{k=0}^{N-1} \underline{x}^T(k) \mathbf{Q} \underline{x}(k) + \underline{u}^T(k) \mathbf{R} \underline{u}(k) \quad (3.91)$$

Where $\mathbf{Q} \geq 0$ is a constant positive semi-definite matrix and $\mathbf{R} > 0$ a constant positive definite matrix. The optimal control is given by:

$$\underline{u}(k) = -\mathbf{K}(k) \underline{x}(k) \quad (3.92)$$

Where:

$$\mathbf{K}(k) = (\mathbf{R} + \mathbf{B}^T \mathbf{P}(k+1) \mathbf{B})^{-1} \mathbf{B}^T \mathbf{P}(k+1) \mathbf{A} \quad (3.93)$$

And $\mathbf{P}(k)$ is given by the solution of the discrete time Riccati equation:

$$\begin{cases} \mathbf{P}(k) = \mathbf{A}^T \mathbf{P}(k+1) \mathbf{A} + \mathbf{Q} - \mathbf{A}^T \mathbf{P}(k+1) \mathbf{B} (\mathbf{R} + \mathbf{B}^T \mathbf{P}(k+1) \mathbf{B})^{-1} \mathbf{B}^T \mathbf{P}(k+1) \mathbf{A} \\ \mathbf{P}(N) = \mathbf{S} \end{cases} \quad (3.94)$$

3.10.2 Finite horizon LQ regulator with zero terminal state

We consider the following performance criteria to be minimized:

$$J(\underline{u}(k)) = \frac{1}{2} \sum_{k=0}^{N-1} \underline{x}^T(k) \mathbf{Q} \underline{x}(k) + \underline{u}^T(k) \mathbf{R} \underline{u}(k) + 2 \underline{x}^T(k) \mathbf{S} \underline{u}(k) \quad (3.95)$$

⁴Doyle J.C., Guaranteed margins for LQG regulators, IEEE Transactions on Automatic Control, Volume: 23, Issue: 4, Aug 1978

With the constraint on terminal state:

$$\underline{x}(N) = \underline{0} \quad (3.96)$$

We will assume that matrices $\mathbf{R} > 0$ and $\mathbf{Q} - \mathbf{S}\mathbf{R}^{-1}\mathbf{S}^T \geq 0$ are symmetric. Ntogramatzidis¹ has shown the results presented hereafter: denote by \mathbf{P}_1 and \mathbf{P}_2 the positive semi-definite solutions of the following continuous time algebraic Riccati equations:

$$\begin{cases} \mathbf{0} = \mathbf{P}_1 + (\mathbf{A}^T\mathbf{P}_1\mathbf{B} + \mathbf{S}) (\mathbf{R} + \mathbf{B}^T\mathbf{P}_1\mathbf{B})^{-1} (\mathbf{B}^T\mathbf{P}_1\mathbf{A} + \mathbf{S}^T) \\ \quad - \mathbf{A}^T\mathbf{P}_1\mathbf{A} - \mathbf{Q} \\ \mathbf{0} = \mathbf{P}_2 + (\mathbf{A}_b^T\mathbf{P}_2\mathbf{B}_b + \mathbf{S}_b) (\mathbf{R}_b + \mathbf{B}_b^T\mathbf{P}_2\mathbf{B}_b)^{-1} (\mathbf{B}_b^T\mathbf{P}_2\mathbf{A}_b + \mathbf{S}_b^T) \\ \quad - \mathbf{A}_b^T\mathbf{P}_2\mathbf{A}_b - \mathbf{Q}_b \end{cases} \quad (3.97)$$

Where:

$$\begin{cases} \mathbf{A}_b = \mathbf{A}^{-1} \\ \mathbf{B}_b = -\mathbf{A}^{-1}\mathbf{B} \\ \mathbf{Q}_b = \mathbf{A}^{-T}\mathbf{Q}\mathbf{A}^{-1} \\ \mathbf{R}_b = \mathbf{R} - \mathbf{S}^T\mathbf{A}^{-1}\mathbf{B} - \mathbf{B}^T\mathbf{A}^{-T}\mathbf{S} + \mathbf{B}^T\mathbf{A}^{-T}\mathbf{Q}\mathbf{A}^{-1}\mathbf{B} \\ \mathbf{S}_b = \mathbf{A}^{-T}\mathbf{S} - \mathbf{A}^{-T}\mathbf{Q}\mathbf{A}^{-1}\mathbf{B} \end{cases} \quad (3.98)$$

We will denote by \mathbf{K}_1 and \mathbf{K}_2 the following *infinite* horizon gain matrices:

$$\begin{cases} \mathbf{K}_1 = (\mathbf{R} + \mathbf{B}^T\mathbf{P}_1\mathbf{B})^{-1} (\mathbf{B}^T\mathbf{P}_1\mathbf{A} + \mathbf{S}^T) \\ \mathbf{K}_2 = (\mathbf{R}_b + \mathbf{B}_b^T\mathbf{P}_2\mathbf{B}_b)^{-1} (\mathbf{B}_b^T\mathbf{P}_2\mathbf{A}_b + \mathbf{S}_b^T) \end{cases} \quad (3.99)$$

Then the optimal control is:

$$\underline{u}(k) = \begin{cases} -\mathbf{K}(k)\underline{x}(k) \quad \forall 0 \leq k < N \\ 0 \quad \text{for } k = N \end{cases} \quad (3.100)$$

Where:

$$\begin{cases} \mathbf{K}(k) = (\mathbf{R} + \mathbf{B}^T\mathbf{P}(k+1)\mathbf{B})^{-1} (\mathbf{B}^T\mathbf{P}(k+1)\mathbf{A} + \mathbf{S}^T) \\ \mathbf{P}(k) = \mathbf{X}_2(k)\mathbf{X}_1^{-1}(k) \end{cases} \quad (3.101)$$

And:

$$\begin{cases} \mathbf{X}_1(k) = (\mathbf{A} - \mathbf{B}\mathbf{K}_1)^k - (\mathbf{A}_b - \mathbf{B}_b\mathbf{K}_2)^{(k-N)} (\mathbf{A} - \mathbf{B}\mathbf{K}_1)^N \\ \mathbf{X}_2(k) = \mathbf{P}_1 (\mathbf{A} - \mathbf{B}\mathbf{K}_1)^k + \mathbf{P}_2 (\mathbf{A}_b - \mathbf{B}_b\mathbf{K}_2)^{(k-N)} (\mathbf{A} - \mathbf{B}\mathbf{K}_1)^N \end{cases} \quad (3.102)$$

Matrix $\mathbf{P}(k)$ satisfy the following Riccati difference equation:

$$\begin{aligned} \mathbf{P}(k) + (\mathbf{A}^T\mathbf{P}(k+1)\mathbf{B} + \mathbf{S}) (\mathbf{R} + \mathbf{B}^T\mathbf{P}(k+1)\mathbf{B})^{-1} (\mathbf{B}^T\mathbf{P}(k+1)\mathbf{A} + \mathbf{S}^T) \\ - \mathbf{A}^T\mathbf{P}(k+1)\mathbf{A} - \mathbf{Q} = 0 \end{aligned} \quad (3.103)$$

Furthermore the optimal state $\underline{x}(k)$ and costate $\lambda(k)$ have the following expressions:

$$\begin{cases} \underline{x}(k+1) = (\mathbf{A} - \mathbf{B}\mathbf{K}_1) e_1(k) - (\mathbf{A}_b - \mathbf{B}_b\mathbf{K}_2) e_2(k) \\ \lambda(k+1) = \mathbf{P}_1 (\mathbf{A} - \mathbf{B}\mathbf{K}_1) e_1(k) + \mathbf{P}_2 (\mathbf{A}_b - \mathbf{B}_b\mathbf{K}_2) e_2(k) \end{cases} \quad (3.104)$$

Where:

$$\begin{cases} e_1(k) = (\mathbf{A} - \mathbf{B}\mathbf{K}_1)^k \mathbf{X}_1^{-1}(0)\underline{x}_0 \\ e_2(k) = (\mathbf{A}_b - \mathbf{B}_b\mathbf{K}_2)^{(k-N)} (\mathbf{A} - \mathbf{B}\mathbf{K}_1)^N \mathbf{X}_1^{-1}(0)\underline{x}_0 \end{cases} \quad (3.105)$$

3.10.3 Infinite horizon LQ regulator

For the infinite horizon problem $N \rightarrow \infty$. We will assume that the performance criteria to be minimized is:

$$J(\underline{u}(k)) = \frac{1}{2} \sum_{k=0}^{\infty} \underline{x}^T(k) \mathbf{Q} \underline{x}(k) + \underline{u}^T(k) \mathbf{R} \underline{u}(k) \quad (3.106)$$

Then matrix \mathbf{P} satisfies the following discrete time algebraic Riccati equation:

$$\mathbf{P} + \mathbf{A}^T \mathbf{P} \mathbf{B} (\mathbf{R} + \mathbf{B}^T \mathbf{P} \mathbf{B})^{-1} \mathbf{B}^T \mathbf{P} \mathbf{A} - \mathbf{A}^T \mathbf{P} \mathbf{A} - \mathbf{Q} = \mathbf{0} \quad (3.107)$$

And the discrete time control $\underline{u}(k)$ is given by:

$$\underline{u}(k) = -\mathbf{K} \underline{x}(k) \quad (3.108)$$

Where:

$$\mathbf{K} = (\mathbf{R} + \mathbf{B}^T \mathbf{P} \mathbf{B})^{-1} \mathbf{B}^T \mathbf{P} \mathbf{A} \quad (3.109)$$

If (\mathbf{A}, \mathbf{B}) is stabilizable, then the closed loop system is stable, meaning that all the eigenvalues of $(\mathbf{A} - \mathbf{B}\mathbf{K})$, with \mathbf{K} given by (3.109), will lie within the unit disk (i.e. have magnitudes less than 1). Let's define the following symplectic matrix⁵:

$$\mathbf{H} = \begin{bmatrix} \mathbf{A}^{-1} & \mathbf{A}^{-1} \mathbf{G} \\ \mathbf{Q} \mathbf{A}^{-1} & \mathbf{A}^T + \mathbf{Q} \mathbf{A}^{-1} \mathbf{G} \end{bmatrix} \quad (3.110)$$

Where:

$$\mathbf{G} = \mathbf{B} \mathbf{R}^{-1} \mathbf{B}^T \quad (3.111)$$

A symplectic matrix is a matrix which satisfies:

$$\mathbf{H}^T \mathbf{J} \mathbf{H} = \mathbf{J} \text{ where } \mathbf{J} = \begin{bmatrix} 0 & \mathbf{I} \\ -\mathbf{I} & 0 \end{bmatrix} \text{ and } \mathbf{J}^{-1} = -\mathbf{J} \quad (3.112)$$

This implies:

$$\begin{aligned} \mathbf{H}^T \mathbf{J} &= \mathbf{J} \mathbf{H}^{-1} \Leftrightarrow \mathbf{J}^{-1} \mathbf{H}^T \mathbf{J} = \mathbf{H}^{-1} \\ \Rightarrow \mathbf{H}^{-1} &= \begin{bmatrix} \mathbf{A} + \mathbf{G} \mathbf{A}^{-T} \mathbf{Q} & -\mathbf{G} \mathbf{A}^{-T} \\ -\mathbf{A}^{-T} \mathbf{Q} & \mathbf{A}^{-T} \end{bmatrix} \end{aligned} \quad (3.113)$$

Where $\mathbf{A}^{-T} = (\mathbf{A}^{-1})^T$. Under detectability and stabilizability assumptions, it can be shown that the eigenvalues of the closed loop plant (that are the eigenvalues of $\mathbf{A} - \mathbf{B}\mathbf{K}$) are equal to the n eigenvalues inside the unit circle of the Hamiltonian matrix \mathbf{H} . The optimal control stabilizes the plant. Furthermore if the $2n \times n$ matrix $\begin{bmatrix} \mathbf{X}_1 \\ \mathbf{X}_2 \end{bmatrix}$ has columns that comprise all the eigenvectors associated with the n eigenvalues of the Hamiltonian matrix \mathbf{H} outside the unit

⁵Alan J. Laub, A Schur Method for Solving Algebraic Riccati equations, IEEE Transactions On Automatic Control, VOL. AC-24, NO. 6, December 1979

circle (unstable eigenvalues) then \mathbf{X}_1 is invertible and the positive semi-definite solution of the *algebraic Riccati equation (ARE)* is:

$$\mathbf{P} = \mathbf{X}_2 \mathbf{X}_1^{-1} \tag{3.114}$$

Thus matrix \mathbf{P} for the optimal steady state feedback can be computed thanks to the unstable (eigenvalues outside the unit circle) eigenvectors of \mathbf{H} or the stable (eigenvalues inside the unit circle) eigenvectors of \mathbf{H}^{-1} .

Chapter 4

Design methods

4.1 Characteristics polynomials

Let's consider the following state space realization $(\mathbf{A}, \mathbf{B}, \mathbf{N})$:

$$\begin{cases} \dot{\underline{x}}(t) = \mathbf{A}\underline{x}(t) + \mathbf{B}u(t) \\ \underline{z}(t) = \mathbf{N}\underline{x}(t) \end{cases} \quad (4.1)$$

We will assume that $(\mathbf{A}, \mathbf{B}, \mathbf{N})$ is minimal, or equivalently that (\mathbf{A}, \mathbf{B}) is controllable and (\mathbf{A}, \mathbf{N}) is observable, or equivalently that the following loop gain (or open loop) transfer function is irreducible:

$$G(s) = \mathbf{N}(s\mathbb{I} - \mathbf{A})^{-1} \mathbf{B} = \frac{\mathbf{N} \text{Adj}(s\mathbb{I} - \mathbf{A}) \mathbf{B}}{\det(s\mathbb{I} - \mathbf{A})} = \frac{N(s)}{D(s)} \quad (4.2)$$

The polynomial $D(s) = \det(s\mathbb{I} - \mathbf{A})$ is the loop gain characteristics polynomial, which is assumed to be of degree n , and polynomial matrix $N(s)$ is the numerator of $\mathbf{N}(s\mathbb{I} - \mathbf{A})^{-1} \mathbf{B}$. From the fact that the numerator of $G(s)$ involves $\text{Adj}(s\mathbb{I} - \mathbf{A})$ it is clear that the degree of its numerator $N(s)$, which will be denoted m , is strictly lower than the degree of its denominator $D(s)$, which will be denoted n :

$$\text{deg}(N(s)) = m < \text{deg}(D(s)) = n \quad (4.3)$$

It can be shown that for single-input single-output (SISO) systems we have the following relationship where $N(s)$ is the polynomial (not matrix) numerator of the transfer function:

$$G(s) = \mathbf{N}(s\mathbb{I} - \mathbf{A})^{-1} \mathbf{B} = \frac{\det \left(\begin{bmatrix} s\mathbb{I} - \mathbf{A} & -\mathbf{B} \\ \mathbf{N} & 0 \end{bmatrix} \right)}{\det(s\mathbb{I} - \mathbf{A})} = \frac{N(s)}{D(s)} \quad (4.4)$$

Now let's assume that the system is closed thanks to the following output (not state !) feedback control $u(t)$:

$$u(t) = -k_p \mathbf{K}_o \underline{z}(t) + Hr(t) \quad (4.5)$$

Where:

- k_p is a scaling factor
- \mathbf{K}_o is the output (not state !) feedback matrix gain
- H is the feedforward matrix gain

Then the state matrix of the closed loop system reads $\mathbf{A} - k_p \mathbf{B} \mathbf{K}_o \mathbf{N}$ and the polynomial $\det(s\mathbb{I} - \mathbf{A} + k_p \mathbf{B} \mathbf{K}_o \mathbf{N})$ is the closed loop characteristics polynomial.

4.2 Root Locus technique reminder

The root locus technique¹ has been developed in 1948 by Walter R. Evans (1920-1999). This is a graphical method for sketching in the s -plane the locus of roots of the following polynomial when parameter k_p varies to 0 to infinity:

$$\det(s\mathbb{I} - \mathbf{A} + k_p \mathbf{B} \mathbf{K}_o \mathbf{N}) = D(s) + k_p N(s) \quad (4.6)$$

Usually polynomial $D(s) + k_p N(s)$ represents the denominator of a closed loop transfer function. Polynomial $D(s) + k_p N(s)$ represents here the denominator of the closed loop transfer function when control $u(t)$ reads:

$$u(t) = -k_p \mathbf{K}_o y(t) + Hr(t) \quad (4.7)$$

Usually polynomial $D(s) + k_p N(s)$ represents the denominator of a closed loop transfer function.

It is worth noticing that the roots of $D(s) + k_p N(s)$ are also the roots of $1 + k_p \frac{N(s)}{D(s)}$:

$$D(s) + k_p N(s) = 0 \Leftrightarrow 1 + k_p \frac{N(s)}{D(s)} = 0 \Leftrightarrow G(s) = -1 \quad (4.8)$$

Without loss of generality let's define transfer function $F(s)$ as follows:

$$F(s) = \frac{N(s)}{D(s)} = a \frac{\prod_{j=1}^m (s - z_j)}{\prod_{i=1}^n (s - p_i)} \quad (4.9)$$

Transfer function $G(s) = k_p F(s)$ is called the loop transfer function. In the SISO case the numerator of the loop transfer function $G(s)$ is scalar as well as its denominator.

Equation $G(s) = -1$ can be equivalently split into two equations:

$$\begin{cases} |G(s)| = 1 \\ \arg(G(s)) = (2k + 1)\pi, \quad k = 0, \pm 1, \dots \end{cases} \quad (4.10)$$

The magnitude condition can always be satisfied by a suitable choice of k_p . On the other hand the phase condition does not depend on the value of k_p but only on the sign of k_p . Thus we have to find all the points in the s -plane that satisfy the phase condition. When scalar gain k_p varies from zero to infinity (i.e. k_p is positive), the root locus technique is based on the the following rules:

¹Walter R. Evans , Graphical Analysis of Control Systems, Transactions of the American Institute of Electrical Engineers, vol. 67, pp. 547 - 551, 1948

- The root locus is symmetrical with respect to the horizontal real axis (because roots are either real or complex conjugate);
- The number of branches is equal to the number of poles of the loop transfer function. Thus the root locus has n branches;
- The root locus starts at the n poles of the loop transfer function;
- The root locus ends at the zeros of the loop transfer function. Thus m branches of the root locus end on the m zeros of $F(s)$ and there are $(n-m)$ asymptotic branches;
- Assuming that coefficient a in $F(s)$ is positive, a point s^* on the real axis belongs to the root locus as soon as there is an odd number of poles and zeros on its right. Conversely assuming that coefficient a in $F(s)$ is negative, a point s^* on the real axis belongs to the root locus as soon as there is an even number of poles and zeros on its right. Be careful to take into account the multiplicity of poles and zeros in the counting process;
- The $(n-m)$ asymptotic branches of the root locus which diverge to ∞ are asymptotes.
 - The angle δ_k of each asymptote with the real axis is defined by:

$$\delta_k = \frac{\pi + \arg(a) + 2k\pi}{n-m} \quad \forall k = 0, \dots, n-m-1 \quad (4.11)$$

- Denoting by p_i the n poles of the loop transfer function (that are the roots of $D(s)$) and by z_j the m zeros of the loop transfer function (that are the roots of $N(s)$), the asymptotes intersect the real axis at a point (called pivot or centroid) given by:

$$\sigma = \frac{\sum_{i=1}^n p_i - \sum_{j=1}^m z_j}{n-m} \quad (4.12)$$

- The breakaway / break-in points are located at the roots s_b of the following equation as soon as there is an odd (if coefficient a in $F(s)$ is positive) or even (if coefficient a in $F(s)$ is negative) number of poles and zeros on its right (Be careful to take into account the multiplicity of poles and zeros in the counting process):

$$\begin{aligned} \frac{d}{ds} \left(\frac{1}{F(s)} \right)_{s=s_b} = 0 &\Leftrightarrow \frac{d}{ds} \left(\frac{D(s)}{N(s)} \right)_{s=s_b} = 0 \\ &\Leftrightarrow D'(s_b)N(s_b) - D(s_b)N'(s_b) = 0 \end{aligned} \quad (4.13)$$

4.3 Symmetric Root Locus

4.3.1 Chang-Letov design procedure

In this section we focus on single-input single-output (SISO) plants represented by its transfer function (4.2) for which we study the problem of minimizing the

following performance index:

$$J(u(t)) = \frac{1}{2} \int_0^\infty (\underline{z}^T(t)\underline{z}(t) + \mathbf{R}u^2(t)) dt \text{ where } \mathbf{R} > 0 \quad (4.14)$$

Let $\underline{z}(t)$ be the *controlled* output: this is a *fictitious* output which represents the output of interest for the design. We will assume that the output $\underline{z}(t)$ can be expressed as a linear function of the state vector $\underline{x}(t)$ as $\underline{z}(t) = \mathbf{N}\underline{x}(t)$. Then the cost to be minimized reads:

$$\begin{cases} J(u(t)) = \frac{1}{2} \int_0^\infty (\underline{z}^T(t)\underline{z}(t) + \mathbf{R}u^2(t)) dt \\ \underline{z}(t) = \mathbf{N}\underline{x}(t) \end{cases} \quad (4.15)$$

$$\Rightarrow J(u(t)) = \frac{1}{2} \int_0^\infty (\underline{x}^T(t)\mathbf{N}^T\mathbf{N}\underline{x}(t) + \mathbf{R}u^2(t)) dt$$

This cost is similar to cost defined in (3.2):

$$J(u(t)) = \frac{1}{2} \int_0^\infty (\underline{x}^T(t)\mathbf{Q}\underline{x}(t) + u^T(t)\mathbf{R}u(t)) dt \quad (4.16)$$

Where:

$$\mathbf{Q} = \mathbf{N}^T\mathbf{N} \quad (4.17)$$

We recall that the cost to minimize is *constrained* by the dynamics of the system with the following state space representation:

$$\begin{cases} \dot{\underline{x}}(t) = \mathbf{A}\underline{x}(t) + \mathbf{B}u(t) \\ \underline{z}(t) = \mathbf{N}\underline{x}(t) \end{cases} \quad (4.18)$$

From this state space representation we obtain the following open loop transfer function which is written as the ratio between a numerator $N(s)$ and a denominator $D(s)$:

$$\mathbf{N}(s\mathbb{I} - \mathbf{A})^{-1}\mathbf{B} = \frac{N(s)}{D(s)} \quad (4.19)$$

The purpose of this section is to have some insight on how to drive the modes of the closed loop plant thanks to the LQR design. We recall that the cost (4.14) is minimized by choosing the following control law, where \mathbf{P} is the solution of the algebraic Riccati equation:

$$\begin{cases} u(t) = -\mathbf{K}\underline{x}(t) \\ \mathbf{K} = \mathbf{R}^{-1}\mathbf{B}^T\mathbf{P} \end{cases} \quad (4.20)$$

This leads the classical structure of full-state feedback control with is represented in Figure 4.1 where $\Phi(s) = (s\mathbb{I} - \mathbf{A})^{-1}$.

Let $D(s)$ be the open loop gain characteristics polynomial and $\beta(s)$ be the closed loop characteristic polynomial:

$$\begin{cases} D(s) = \det(s\mathbb{I} - \mathbf{A}) \\ \beta(s) = \det(s\mathbb{I} - \mathbf{A} + \mathbf{B}\mathbf{K}) \end{cases} \quad (4.21)$$

In the single control case which is under consideration, it can be shown (see section 4.3.2) that the characteristic polynomial of the closed loop system is

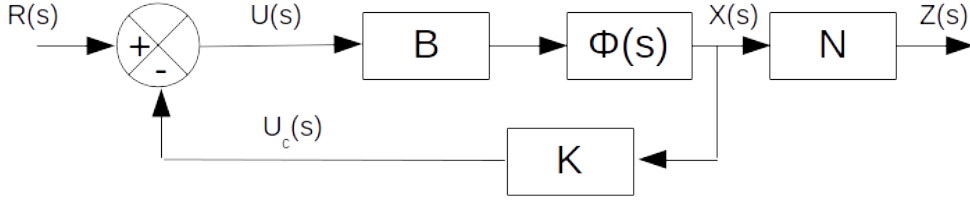

Figure 4.1: Full-state feedback control

linked with the numerator and the denominator of the loop transfer function as follows:

$$\beta(s)\beta(-s) = D(s)D(-s) + \frac{1}{\mathbf{R}}N(s)N(-s) \quad (4.22)$$

This relationship can be associated with the root locus of $G(s)G(-s) = \frac{N(s)N(-s)}{D(s)D(-s)}$ where fictitious gain $k_p = \frac{1}{\mathbf{R}}$ varies from 0 to ∞ . This leads to the so-called Chang-Letov design procedure, which enables to find the closed loop poles based on the open loop poles and zeros of $G(s)G(-s)$. The difference with the root locus of $G(s)$ is that both the open loop poles and zeros and their reflections about the imaginary axis have to be taken into account (this is due to the multiplication by $G(-s)$). The actual closed loop poles are those located in the left half plane with negative real part; indeed optimal control leads always to a stabilizing gain. It is worth noticing that matrix \mathbf{N} is actually a design parameter which is used to shape the root locus.

4.3.2 Proof of the symmetric root locus result

The proof of (4.22) can be done as follows: taking the determinant of the Kalman equality (3.76) and having in mind that $\det(\mathbf{M}^T) = \det(\mathbf{M})$ and that for SISO systems \mathbf{R} is scalar yields:

$$\begin{aligned} \det\left(\left(\mathbb{I} + \mathbf{K}\Phi(-s)\mathbf{B}\right)^T \mathbf{R} \left(\mathbb{I} + \mathbf{K}\Phi(s)\mathbf{B}\right)\right) &= \det\left(\mathbf{R} + \left(\Phi(-s)\mathbf{B}\right)^T \mathbf{Q} \left(\Phi(s)\mathbf{B}\right)\right) \\ \Leftrightarrow \det\left(\left(\mathbb{I} + \mathbf{K}\Phi(-s)\mathbf{B}\right)^T \left(\mathbb{I} + \mathbf{K}\Phi(s)\mathbf{B}\right)\right) &= \det\left(\mathbb{I} + \frac{\left(\Phi(-s)\mathbf{B}\right)^T \mathbf{Q} \left(\Phi(s)\mathbf{B}\right)}{\mathbf{R}}\right) \\ \Leftrightarrow \det\left(\left(\mathbb{I} + \mathbf{K}\Phi(-s)\mathbf{B}\right)^T\right) \det\left(\mathbb{I} + \mathbf{K}\Phi(s)\mathbf{B}\right) &= \det\left(\mathbb{I} + \frac{\left(\Phi(-s)\mathbf{B}\right)^T \mathbf{Q} \left(\Phi(s)\mathbf{B}\right)}{\mathbf{R}}\right) \\ \Leftrightarrow \det\left(\mathbb{I} + \mathbf{K}\Phi(-s)\mathbf{B}\right) \det\left(\mathbb{I} + \mathbf{K}\Phi(s)\mathbf{B}\right) &= \det\left(\mathbb{I} + \frac{\left(\Phi(-s)\mathbf{B}\right)^T \mathbf{Q} \left(\Phi(s)\mathbf{B}\right)}{\mathbf{R}}\right) \end{aligned} \quad (4.23)$$

Where:

$$\Phi(s) = (s\mathbb{I} - \mathbf{A})^{-1} = \frac{\text{Adj}(s\mathbb{I} - \mathbf{A})}{\det(s\mathbb{I} - \mathbf{A})} \quad (4.24)$$

Furthermore, it has been seen in (3.70) that thanks to the Schur's formula we have:

$$\det\left(\mathbb{I} + \mathbf{K}\Phi(s)\mathbf{B}\right) = \frac{\det(s\mathbb{I} - \mathbf{A} + \mathbf{BK})}{\det(s\mathbb{I} - \mathbf{A})} \quad (4.25)$$

Let $D(s)$ be the open loop gain characteristics polynomial and $\beta(s)$ be the closed loop characteristic polynomial:

$$\begin{cases} D(s) = \det(s\mathbb{I} - \mathbf{A}) \\ \beta(s) = \det(s\mathbb{I} - \mathbf{A} + \mathbf{BK}) \end{cases} \quad (4.26)$$

As a consequence, using (4.25) in the left part of (4.23) yields:

$$\frac{\beta(s)\beta(-s)}{D(s)D(-s)} = \det\left(\mathbb{I} + \frac{(\Phi(-s)\mathbf{B})^T \mathbf{Q} (\Phi(s)\mathbf{B})}{\mathbf{R}}\right) \quad (4.27)$$

In the single control case \mathbf{R} and \mathbb{I} are scalars ($\mathbb{I} = 1$). Using $\mathbf{Q} = \mathbf{N}^T \mathbf{N}$ (4.27) becomes:

$$\begin{aligned} \frac{\beta(s)\beta(-s)}{D(s)D(-s)} &= \det\left(1 + \frac{(\mathbf{N}\Phi(-s)\mathbf{B})^T (\mathbf{N}\Phi(s)\mathbf{B})}{\mathbf{R}}\right) \\ &= 1 + \frac{(\mathbf{N}\Phi(-s)\mathbf{B})^T (\mathbf{N}\Phi(s)\mathbf{B})}{\mathbf{R}} \end{aligned} \quad (4.28)$$

We recognize in $\mathbf{N}\Phi(s)\mathbf{B} = \mathbf{N}(s\mathbb{I} - \mathbf{A})^{-1}\mathbf{B}$ the open loop transfer function $G(s)$ which is the ratio between numerator polynomial $N(s)$ and denominator polynomial $D(s)$:

$$G(s) = \mathbf{N}\Phi(s)\mathbf{B} = \mathbf{N}(s\mathbb{I} - \mathbf{A})^{-1}\mathbf{B} = \frac{N(s)}{D(s)} \quad (4.29)$$

Using (4.29) in (4.28) yields:

$$\begin{aligned} \frac{\beta(s)\beta(-s)}{D(s)D(-s)} &= 1 + \frac{1}{\mathbf{R}} \frac{N(s)N(-s)}{D(s)D(-s)} \\ \Leftrightarrow \beta(s)\beta(-s) &= D(s)D(-s) + \frac{1}{\mathbf{R}} N(s)N(-s) \end{aligned} \quad (4.30)$$

This complete the proof.

4.4 Asymptotic properties

We will see that Kalman equality allows for loop shaping through LQR design. Lectures from professor Faryar Jabbari (Henry Samueli School of Engineering, University of California) and professor Perry Y. Li (University of Minnesota) are the primary sources of this section.

We recall that $\Phi(s) = (s\mathbb{I} - \mathbf{A})^{-1}$ where $\dim(\mathbf{A}) = n \times n$ and that $\mathbf{Q} = \mathbf{N}^T \mathbf{N}$. For simplicity, we make in this section the following assumptions:

$$\mathbf{R} = \rho^2 \mathbb{I} \quad (4.31)$$

4.4.1 Closed loop poles location

Using (4.31) relationship (4.22) reads:

$$\beta(s)\beta(-s) = D(s)D(-s) + \frac{1}{\rho^2} N(s)N(-s) \quad (4.32)$$

From (4.32) we can get the following results:

- When ρ is large, i.e. $1/\rho$ is small so that the control energy is weighted very heavily in the performance index, the zeros of $\beta(s)$, that are the closed loop poles, approach the stable open loop poles or the negative of the unstable open loop poles:

$$\beta(s)\beta(-s) \approx D(s)D(-s) \text{ as } \rho \rightarrow \infty \quad (4.33)$$

- When ρ is small (i.e. $\rho \rightarrow 0$) then $1/\rho$ is large and the control is cheap. Then the zeros of $\beta(s)$, that are the closed loop poles, approach the stable open loop zeros or the negative of the non-minimum phase open loop zeros:

$$\beta(s)\beta(-s) \approx \frac{1}{\rho^2}N(s)N(-s) \text{ as } \rho \rightarrow 0 \quad (4.34)$$

Equation (4.34) shows that any roots of $\beta(s)\beta(-s)$ that remains finite as $\rho \rightarrow 0$ must tend toward the zeros of $N(s)N(-s)$. But from (4.3) we know that the degree of $N(s)N(-s)$, say $2m$, is less than the degree of $\beta(s)\beta(-s)$, which is $2n$. Therefore m roots of $\beta(s)$ are the roots of $N(s)N(-s)$ in the open left half plane (*stable* roots). The remaining $n - m$ roots of $\beta(s)$ asymptotically approach infinity in the left half plane. For very large s we can ignore all but the highest power of s in (4.32) so that the magnitude (or modulus) of the roots that tend toward infinity shall satisfy the following approximate relation:

$$(-1)^n s^{2n} \approx \frac{b_m^2}{\rho^2} (-1)^m s^{2m} \quad (4.35)$$

Where we denote:

$$\begin{cases} \beta(s) = \det(s\mathbb{I} - \mathbf{A} + \mathbf{BK}) = s^n + \beta_{n-1}s^{n-1} + \dots + \beta_1 s + \beta_0 \\ N(s) = b_m s^m + b_{m-1}s^{m-1} + \dots + b_1 s + b_0 \end{cases} \quad (4.36)$$

The roots of $\beta(-s)$ are the reflection across the imaginary of the roots of $\beta(s)$. Now express s in the exponential form:

$$s = r e^{j\theta} \quad (4.37)$$

We get from (4.35):

$$(-1)^n r^{2n} e^{j2n\theta} \approx \frac{b_m^2}{\rho^2} (-1)^m r^{2m} e^{j2m\theta} \Rightarrow r^{2(n-m)} \approx \frac{b_m^2}{\rho^2} \quad (4.38)$$

Therefore, the remaining $n - m$ zeros of $\beta(s)$ lie on a circle of radius r defined by:

$$r \approx \left(\frac{b_m}{\rho} \right)^{\frac{1}{n-m}} \quad (4.39)$$

The particular pattern to which the $2(n - m)$ solutions of (4.39) lie is known as the Butterworth configuration. The angle of the $2(n - m)$ branches which diverge to ∞ are obtained by adapting relationship (4.11) to the case where transfer function reads $G(s)G(-s) = \frac{N(s)N(-s)}{D(s)D(-s)}$.

4.4.2 Shape of the magnitude of the open-loop gain $\mathbf{K}\Phi(s)\mathbf{B}$

For this particular choice of \mathbf{Q} and \mathbf{R} used in this section, Kalman equality (3.76) becomes:

$$\begin{aligned} (\mathbb{I} + \mathbf{K}\Phi(-s)\mathbf{B})^T (\mathbb{I} + \mathbf{K}\Phi(s)\mathbf{B}) &= \mathbb{I} + \frac{1}{\rho^2} (\Phi(-s)\mathbf{B})^T \mathbf{N}^T \mathbf{N} (\Phi(s)\mathbf{B}) \\ &= \mathbb{I} + \frac{1}{\rho^2} (\mathbf{N}\Phi(-s)\mathbf{B})^T (\mathbf{N}\Phi(s)\mathbf{B}) \end{aligned} \quad (4.40)$$

Denoting by $\lambda(\mathbf{X}(s))$ the eigenvalues of matrix $\mathbf{X}(s)$ and by $\sigma(\mathbf{X}(s))$ its singular values (that are the strictly positive eigenvalues of either $\mathbf{X}^T(s)\mathbf{X}(s)$ or $\mathbf{X}(s)\mathbf{X}^T(s)$), the preceding equality implies:

$$\begin{aligned} \lambda\left((\mathbb{I} + \mathbf{K}\Phi(-s)\mathbf{B})^T (\mathbb{I} + \mathbf{K}\Phi(s)\mathbf{B})\right) &= 1 + \frac{1}{\rho^2} \lambda\left((\mathbf{N}\Phi(-s)\mathbf{B})^T (\mathbf{N}\Phi(s)\mathbf{B})\right) \\ \Leftrightarrow \sigma(\mathbb{I} + \mathbf{K}\Phi(s)\mathbf{B}) &= \sqrt{1 + \frac{1}{\rho^2} \sigma^2(\mathbf{N}\Phi(s)\mathbf{B})} \end{aligned} \quad (4.41)$$

For the range of frequencies for which $\sigma(\mathbf{N}\Phi(j\omega)\mathbf{B}) \gg 1$ (typically low frequencies) equation (4.41) shows that:

$$\sigma(\mathbf{K}\Phi(s)\mathbf{B}) \approx \frac{1}{\rho} \sigma(\mathbf{N}\Phi(s)\mathbf{B}) \quad (4.42)$$

For SISO system matrices \mathbf{N} and \mathbf{K} have the same dimension. Denoting by $|\mathbf{K}|$ the absolute value of each element of \mathbf{K} we get from the previous equation :

$$\sigma|\mathbf{K}\Phi(s)\mathbf{B}| \approx \frac{1}{\rho} \sigma(\mathbf{N}\Phi(s)\mathbf{B}) \Rightarrow |\mathbf{K}| \approx \frac{|\mathbf{N}|}{\rho} \text{ where } \mathbf{Q} = \mathbf{N}^T \mathbf{N} \quad (4.43)$$

Assuming that $\underline{z} = \mathbf{N}\underline{x}$, then $\mathbf{N}\Phi(s)\mathbf{B}$ represents the transfer function from the control signal $u(t)$ to the controlled output $\underline{z}(t)$. As a consequence:

- The shape of the magnitude of the open-loop gain $\mathbf{K}\Phi(s)\mathbf{B}$ is determined by the magnitude of the transfer function from the control input $u(t)$ to the controlled output $\underline{z}(t)$
- Parameter ρ moves the magnitude Bode plot up and down

Note that although the magnitude of $\mathbf{K}\Phi(s)\mathbf{B}$ mimics the magnitude of $\mathbf{N}\Phi(s)\mathbf{B}$, the phase of the open-loop gain $\mathbf{K}\Phi(s)\mathbf{B}$ always leads to a stable closed-loop with an appropriate phase margin. At high-frequency, it has been seen in Figure 3.3 or Figure 3.4 that the open-loop gain $\mathbf{K}\Phi(j\omega)\mathbf{B}$ can have at most -90 degrees phase for high-frequencies and therefore the *roll-off* rate is at most -20 dB/decade. In practice, this means that for $\omega \gg 1$, and for some constant a , we have the following approximation (remind that $\Phi(s) = (s\mathbb{I} - \mathbf{A})^{-1} = \frac{\text{Adj}(s\mathbb{I} - \mathbf{A})}{\det(s\mathbb{I} - \mathbf{A})}$ so that the degree of the denominator of $\mathbf{K}\Phi(s)\mathbf{B}$ is n and the degree of its numerator is at most $n - 1$):

$$|\mathbf{K}\Phi(j\omega)\mathbf{B}| \approx \frac{a}{\omega\rho} \text{ where } \frac{a}{\rho} = \lim_{s \rightarrow \infty} s |\mathbf{K}\Phi(s)\mathbf{B}| \approx \lim_{s \rightarrow \infty} s \frac{1}{\rho} |\mathbf{N}\Phi(s)\mathbf{B}| \quad (4.44)$$

and therefore the cross-over frequency ω_c is approximately given by:

$$|\mathbf{K}\Phi(j\omega_c)\mathbf{B}| = 1 \approx \frac{a}{\omega_c\rho} \Rightarrow \omega_c \approx \frac{a}{\rho} \quad (4.45)$$

Thus:

- LQR controllers always exhibit a high-frequency magnitude decay of -20 dB/decade. The (slow) -20 dB/decade magnitude decrease is the main shortcoming of state-feedback LQR controllers because it may not be sufficient to clear high-frequency upper bounds on the open-loop gain needed to reject disturbances and/or for robustness with respect to process uncertainty.
- The cross-over frequency is proportional to $1/\rho$ and generally small values for ρ result in faster step responses.

4.4.3 Weighting matrices selection

The preceding results motivates the following design rule extended to the case of multiple input multiple output systems:

- Modal point of view: assuming that all states are available for control, choose \mathbf{N} (remind that $\mathbf{Q} = \mathbf{N}^T\mathbf{N} \Rightarrow \mathbf{Q}^{1/2} = \mathbf{N}$) such that $n - 1$ zeros of $\mathbf{N}\Phi(s)\mathbf{B}$ are at the desired pole location. Then use cheap control $\rho \rightarrow 0$ (and set \mathbf{R} to $\rho^2\mathbb{I}$) to design LQ system so that $n - 1$ poles of the closed loop system approach these desired locations. It is worth noticing that for SISO plants the zeros of $\mathbf{N}\Phi(s)\mathbf{B}$ are also the roots of:

$$\det \left(\begin{bmatrix} s\mathbb{I} - \mathbf{A} & -\mathbf{B} \\ \mathbf{N} & 0 \end{bmatrix} \right) = 0 \quad (4.46)$$

- Frequency point of view: alternatively we have seen that at low frequencies $|\mathbf{K}| \approx \frac{|\mathbf{N}|}{\rho}$ so that the open loop gain is approximately $|\mathbf{K}\Phi(s)\mathbf{B}| \approx \frac{1}{\rho}|\mathbf{N}\Phi(s)\mathbf{B}|$. So the shape of the magnitude of the open-loop gain $\mathbf{K}\Phi(s)\mathbf{B}$ is determined by the magnitude of $\mathbf{N}\Phi(s)\mathbf{B}$, that is the transfer function from the control input $u(t)$ to the controlled output $\underline{z}(t)$. In addition, we have seen that at high frequency $|\mathbf{N}\Phi(j\omega)\mathbf{B}| \approx \frac{a}{\omega\rho}$, where $a = \lim_{s \rightarrow \infty} s|\mathbf{N}\Phi(s)\mathbf{B}|$ is some constant. So we can choose ρ to pick the bandwidth ω_c which is where $|\mathbf{K}\Phi(j\omega)\mathbf{B}| = 1$. Thus choose $\rho \approx \frac{a}{\omega_c}$ where ω_c is the desired bandwidth.

Thus contrary to the Chang-Letov design procedure for Single-Input Single-Output (SISO) systems where scalar \mathbf{R} was the design parameter the following design rules for Multi Input Multi Output (MIMO) systems use matrix \mathbf{Q} as the design parameter. We may also use the fact that if λ_i is a stable eigenvalue (i.e. eigenvalue in the open left half plane) of the Hamiltonian matrix $\mathbf{H} = \begin{bmatrix} \mathbf{A} & -\mathbf{B}\mathbf{R}^{-1}\mathbf{B}^T \\ -\mathbf{Q} & -\mathbf{A}^T \end{bmatrix}$ with eigenvector $\begin{bmatrix} \mathbf{X}_{1i} \\ \mathbf{X}_{2i} \end{bmatrix}$ then λ_i is also an eigenvalue of

$\mathbf{A} - \mathbf{BK}$ with eigenvector \mathbf{X}_{1i} . Therefore in the single input case we can use this result by finding the eigenvalues of \mathbf{H} and then realizing that the stable eigenvalues are the poles of the optimal closed loop plant.

Alternatively, a simpler choice for matrices \mathbf{Q} and \mathbf{R} is given by the Bryson's rule who proposed to take \mathbf{Q} and \mathbf{R} as diagonal matrices such that:

$$\begin{cases} q_{ii} = \frac{1}{\text{max. acceptable value of } z_i^2} \\ r_{jj} = \frac{1}{\text{max. acceptable value of } u_j^2} \end{cases} \quad (4.47)$$

Diagonal matrices \mathbf{Q} and \mathbf{R} are associated to the following performance index where ρ is a free parameter to be set by the designer:

$$J(u(t)) = \frac{1}{2} \int_0^\infty \left(\sum_i q_{ii} z_i^2(t) + \rho^2 \sum_i r_{jj} u_j^2(t) \right) dt \quad (4.48)$$

If after simulation $|z_i(t)|$ is too large then increase q_{ii} ; similarly if after simulation $|u_j(t)|$ is too large then increase r_{jj} .

4.5 Poles shifting in optimal regulator

4.5.1 Mirror property

The purpose of this section is to determine the relationships between the weighting matrix \mathbf{Q} and the closed loop eigenvalues of the optimal regulator.

We recall the expression of the $2n \times 2n$ Hamiltonian matrix \mathbf{H} :

$$\mathbf{H} = \begin{bmatrix} \mathbf{A} & -\mathbf{BR}^{-1}\mathbf{B}^T \\ -\mathbf{Q} & -\mathbf{A}^T \end{bmatrix} \quad (4.49)$$

which corresponds to the following algebraic Riccati equation:

$$\mathbf{A}^T \mathbf{P} + \mathbf{P} \mathbf{A} - \mathbf{P} \mathbf{B} \mathbf{R}^{-1} \mathbf{B}^T \mathbf{P} + \mathbf{Q} = \mathbf{0} \quad (4.50)$$

The characteristic polynomial of matrix \mathbf{H} in (4.49) is given by²:

$$\det(s\mathbb{I} - \mathbf{H}) = \det(s\mathbb{I} - \mathbf{A}) \det(\mathbb{I} - \mathbf{Q}\mathbf{S}(s)) \det(s\mathbb{I} + \mathbf{A}^T) \quad (4.51)$$

Where the term $\mathbf{S}(s)$ is defined by:

$$\mathbf{S}(s) = (s\mathbb{I} - \mathbf{A})^{-1} \mathbf{B} \mathbf{R}^{-1} \mathbf{B}^T (s\mathbb{I} + \mathbf{A}^T)^{-1} \quad (4.52)$$

Setting $\mathbf{Q} = \mathbf{Q}^T = 2\alpha\mathbf{P}$ where $\alpha \geq 0$ is a design parameter then the algebraic Riccati equation reads:

$$\mathbf{Q} = \mathbf{Q}^T = 2\alpha\mathbf{P} \Rightarrow (\mathbf{A} + \alpha\mathbb{I})^T \mathbf{P} + \mathbf{P} (\mathbf{A} + \alpha\mathbb{I}) - \mathbf{P} \mathbf{B} \mathbf{R}^{-1} \mathbf{B}^T \mathbf{P} = \mathbf{0} \quad (4.53)$$

²Y. Ochi and K. Kanai, Pole placement in optimal regulator by continuous pole-shifting, Journal of Guidance Control and Dynamics, Vol. 18, No. 6 (1995), pp. 1253-1258

which corresponds to the following Hamiltonian matrix \mathbf{H} :

$$\mathbf{H} = \begin{bmatrix} \mathbf{A} + \alpha\mathbb{I} & -\mathbf{B}\mathbf{R}^{-1}\mathbf{B}^T \\ \mathbf{0} & -(\mathbf{A} + \alpha\mathbb{I})^T \end{bmatrix} \quad (4.54)$$

Let λ_i be the open loop eigenvalues, that are the eigenvalues of matrix \mathbf{A} , and λ_{Ki} be the corresponding closed loop eigenvalues, that are the eigenvalues of matrix $\mathbf{A} - \mathbf{B}\mathbf{K}$. Denoting by $Re(\lambda_{Ki})$ the real part of λ_{Ki} it can be shown³ that the positive semi-definite real symmetric solution \mathbf{P} of (4.53) is such that the following mirror property holds:

$$\begin{cases} Re(\lambda_{Ki}) \leq -\alpha \\ Im(\lambda_{Ki}) = Im(\lambda_i) \\ (\alpha + \lambda_i)^2 = (\alpha + \lambda_{Ki})^2 \end{cases} \quad \forall i = 1, \dots, n \quad (4.55)$$

Once the algebraic Riccati equation (4.53) is solved in \mathbf{P} the classical LQR design is applied:

$$\begin{cases} u(t) = -\mathbf{K}\underline{x}(t) \\ \mathbf{K} = \mathbf{R}^{-1}\mathbf{B}^T\mathbf{P} \end{cases} \quad (4.56)$$

Moreover, Amin³ has shown that given a controllable pair (\mathbf{A}, \mathbf{B}) , a positive definite symmetric matrix \mathbf{R} and a positive real constant α such that $\alpha + Re(\lambda_i) \geq 0$, then the algebraic Riccati equation (4.53) has a unique positive definite solution $\mathbf{P} = \mathbf{P}^T > 0$ satisfying the following property:

$$\alpha + Re(\lambda_i) \geq 0 \Rightarrow \begin{cases} Re(\lambda_{Ki}) = -(2\alpha + Re(\lambda_i)) \\ Im(\lambda_{Ki}) = Im(\lambda_i) \end{cases} \quad (4.57)$$

It is worth noticing that the algebraic Riccati equation (4.53) can be changed into a Lyapunov equation by pre- and post-multiplying (4.53) by \mathbf{P}^{-1} and setting $\mathbf{X} := \mathbf{P}^{-1}$:

$$\begin{aligned} (\mathbf{A} + \alpha\mathbb{I})^T \mathbf{P} + \mathbf{P} (\mathbf{A} + \alpha\mathbb{I}) - \mathbf{P}\mathbf{B}\mathbf{R}^{-1}\mathbf{B}^T\mathbf{P} &= \mathbf{0} \\ \Rightarrow \mathbf{P}^{-1} (\mathbf{A} + \alpha\mathbb{I})^T + (\mathbf{A} + \alpha\mathbb{I}) \mathbf{P}^{-1} - \mathbf{B}\mathbf{R}^{-1}\mathbf{B}^T &= \mathbf{0} \\ \mathbf{X} := \mathbf{P}^{-1} \Rightarrow \mathbf{X} (\mathbf{A} + \alpha\mathbb{I})^T + (\mathbf{A} + \alpha\mathbb{I}) \mathbf{X} &= \mathbf{B}\mathbf{R}^{-1}\mathbf{B}^T \end{aligned} \quad (4.58)$$

Matrix \mathbf{R} remains the degree of freedom for the design and it seems that it may be used to set the damping ratio of the complex conjugate dominant poles for example. Unfortunately (4.54) indicates that the eigenvalues of the Hamiltonian matrix \mathbf{H} , which are closely related to eigenvalues of the closed loop system, are independent of matrix \mathbf{R} . Thus matrix \mathbf{R} has no influence on the location of the closed loop poles in that situation.

Furthermore it is worth reminding that the higher the displacement of closed loop eigenvalues with respect to the open loop eigenvalue is, the higher the control effort is. Thus specifying very fast dominant poles may lead to unacceptable control effort.

³Optimal pole shifting for continuous multivariable linear systems, M. H. Amin, Int. Journal of Control 41 No. 3 (1985), 701-707.

4.5.2 Reduced-order model

The preceding result can be used to recursively shift on the left all the real parts of the poles of a system to any positions while preserving their imaginary parts. Let $\mathbf{A} \in \mathbb{R}^{n \times n}$ be the state matrix of the system to be controlled and $\mathbf{B} \in \mathbb{R}^{n \times m}$ the input matrix. We assume that all the eigenvalues of \mathbf{A} are distinct and that (\mathbf{A}, \mathbf{B}) is controllable and that the symmetric positive definite weighting matrix \mathbf{R} for the control is given. The purpose of this section is to compute the state weighting matrix \mathbf{Q} which leads to the desired closed loop eigenvalues by shifting recursively the actual eigenvalues of the state matrix. It is worth noticing that, through the shifting process, real eigenvalues remain real eigenvalues whereas complex conjugate eigenvalues remain complex conjugate eigenvalues.

The core idea of the method is to consider the transformation $z_i = \mathbf{C}^T \underline{x}$ which leads to consider the following reduced order model where matrix $\mathbf{\Lambda}$ corresponds to the diagonal (or Jordan) form of state matrix \mathbf{A} :

$$z_i = \mathbf{C}^T \underline{x} \Rightarrow \dot{z}_i = \mathbf{\Lambda} z_i + \mathbf{G} \underline{u} \text{ where } \begin{cases} \mathbf{C}^T \mathbf{A} = \mathbf{\Lambda} \mathbf{C}^T \Leftrightarrow \mathbf{A}^T \mathbf{C} = \mathbf{C} \mathbf{\Lambda}^T \\ \mathbf{G} = \mathbf{C}^T \mathbf{B} \end{cases} \quad (4.59)$$

In this new basis the performance index turns to be:

$$J_i = \frac{1}{2} \int_0^\infty \left(z_i^T \tilde{\mathbf{Q}} z_i + \underline{u}^T \mathbf{R} \underline{u} \right) dt \quad (4.60)$$

4.5.3 Shifting one real eigenvalue

Let λ_i be an eigenvalue of \mathbf{A} . We will first assume that λ_i is real. We wish to shift λ_i to λ_{Ki} .

Let \underline{v} be a *left* eigenvector of \mathbf{A} : $\underline{v}^T \mathbf{A} = \lambda_i \underline{v}^T$. In other words, \underline{v} is a (right) eigenvector of \mathbf{A}^T corresponding to λ_i : $\mathbf{A}^T \underline{v} = \lambda_i \underline{v}$. Then we define z_i as follows:

$$z_i := \mathbf{C}^T \underline{x} \text{ where } \mathbf{C} = \underline{v} \quad (4.61)$$

Using the fact that \underline{v} is a (right) eigenvector of \mathbf{A}^T ($z_i = \underline{v}^T \underline{x}$), we can write:

$$\begin{aligned} \dot{z}_i &= \underline{v}^T \mathbf{A} \underline{x} + \underline{v}^T \mathbf{B} \underline{u} \\ &= \underline{v}^T \lambda_i \underline{x} + \underline{v}^T \mathbf{B} \underline{u} \\ &= \lambda_i \underline{v}^T \underline{x} + \underline{v}^T \mathbf{B} \underline{u} \\ &= \lambda_i z_i + \underline{v}^T \mathbf{B} \underline{u} \\ &= \lambda_i z_i + \mathbf{G} \underline{u} \text{ where } \mathbf{G} := \underline{v}^T \mathbf{B} = \mathbf{C}^T \mathbf{B} \end{aligned} \quad (4.62)$$

Then setting $\underline{u} := -\mathbf{R}^{-1} \mathbf{G}^T \tilde{\mathbf{P}} z_i$, where scalar $\tilde{\mathbf{P}} > 0$ is a design parameter, and having in mind that z_i is scalar (thus $\lambda_i \mathbb{I} = \lambda_i$), we get:

$$\dot{z}_i = \left(\lambda_i - \mathbf{G} \mathbf{R}^{-1} \mathbf{G}^T \tilde{\mathbf{P}} \right) z_i \quad (4.63)$$

Let λ_{Ki} be the desired eigenvalue of the preceding reduced-order model. Then we shall have:

$$\lambda_{Ki} = \lambda_i - \mathbf{G} \mathbf{R}^{-1} \mathbf{G}^T \tilde{\mathbf{P}} \quad (4.64)$$

Thus, matrix $\tilde{\mathbf{P}}$ reads:

$$\tilde{\mathbf{P}} = \frac{\lambda_i - \lambda_{Ki}}{\mathbf{G}\mathbf{R}^{-1}\mathbf{G}^T} \quad (4.65)$$

The state weighting matrix \mathbf{Q}_i that will shift the open-loop eigenvalue λ_i to the closed-loop eigenvalue λ_{Ki} is obtained through the following identification: $\dot{z}_i^T \tilde{\mathbf{Q}} z_i = \underline{x}^T \mathbf{Q}_i \underline{x}$. We finally get:

$$z_i = \underline{v}^T \underline{x} := \mathbf{C}^T \underline{x} \Rightarrow \mathbf{Q}_i = \mathbf{C} \tilde{\mathbf{Q}} \mathbf{C}^T \quad (4.66)$$

Matrix $\tilde{\mathbf{Q}}$ is obtained thanks to the corresponding algebraic Riccati equation:

$$\begin{aligned} \mathbf{0} &= \tilde{\mathbf{P}} \lambda_i + \lambda_i \tilde{\mathbf{P}} - \tilde{\mathbf{P}} \mathbf{G} \mathbf{R}^{-1} \mathbf{G}^T \tilde{\mathbf{P}} + \tilde{\mathbf{Q}} \\ \Leftrightarrow \tilde{\mathbf{Q}} &= -2\lambda_i \tilde{\mathbf{P}} + \tilde{\mathbf{P}} \mathbf{G} \mathbf{R}^{-1} \mathbf{G}^T \tilde{\mathbf{P}} \end{aligned} \quad (4.67)$$

4.5.4 Shifting a pair of complex conjugate eigenvalues

The procedure to shift a pair of complex conjugate eigenvalues follows the same idea: let λ_i and $\bar{\lambda}_i$ be a pair of complex conjugate eigenvalues of \mathbf{A} . We wish to shift λ_i and $\bar{\lambda}_i$ to λ_{Ki} and $\bar{\lambda}_{Ki}$.

Let \underline{v} and $\bar{\underline{v}}$ be a pair *left* eigenvectors of \mathbf{A} . In other words, \underline{v} and $\bar{\underline{v}}$ is a pair of (right) eigenvector of \mathbf{A}^T corresponding to λ_i :

$$\begin{aligned} \begin{bmatrix} \underline{v}^T & \bar{\underline{v}}^T \end{bmatrix} \mathbf{A} &= \begin{bmatrix} \underline{v}^T & \bar{\underline{v}}^T \end{bmatrix} \begin{bmatrix} \lambda_i & 0 \\ 0 & \bar{\lambda}_i \end{bmatrix} \\ \Leftrightarrow \mathbf{A}^T \begin{bmatrix} \underline{v} & \bar{\underline{v}} \end{bmatrix} &= \begin{bmatrix} \underline{v} & \bar{\underline{v}} \end{bmatrix} \begin{bmatrix} \lambda_i & 0 \\ 0 & \bar{\lambda}_i \end{bmatrix} \end{aligned} \quad (4.68)$$

In order to manipulate real values, we will use the real part and the imaginary part of the preceding equation. Denoting $\lambda_i := a + j b$, that is $a := \text{Re}(\lambda_i)$ and $b := \text{Im}(\lambda_i)$, the preceding relationship is equivalently replaced by the following one :

$$\begin{aligned} \mathbf{A}^T \begin{bmatrix} \underline{v} & \bar{\underline{v}} \end{bmatrix} &= \begin{bmatrix} \underline{v} & \bar{\underline{v}} \end{bmatrix} \begin{bmatrix} \lambda_i & 0 \\ 0 & \bar{\lambda}_i \end{bmatrix} \\ \Leftrightarrow \mathbf{A}^T \begin{bmatrix} \text{Re}(\underline{v}) & \text{Im}(\underline{v}) \end{bmatrix} &= \begin{bmatrix} \text{Re}(\underline{v}) & \text{Im}(\underline{v}) \end{bmatrix} \begin{bmatrix} a & -b \\ b & a \end{bmatrix} \end{aligned} \quad (4.69)$$

Then define z_i as follows:

$$z_i := \mathbf{C}^T \underline{x} \text{ where } \mathbf{C} = \begin{bmatrix} \text{Re}(\underline{v}) & \text{Im}(\underline{v}) \end{bmatrix} \quad (4.70)$$

Using the fact that \underline{v} and $\bar{\underline{v}}$ is a pair of (right) eigenvector of \mathbf{A}^T , we get:

$$\dot{z}_i = \begin{bmatrix} a & -b \\ b & a \end{bmatrix} z_i + \mathbf{G} \underline{u} \text{ where } \mathbf{G} := \mathbf{C}^T \mathbf{B} \quad (4.71)$$

Then setting $\underline{u} := -\mathbf{R}^{-1} \mathbf{G}^T \tilde{\mathbf{P}} z_i$, where 2×2 positive definite matrix $\tilde{\mathbf{P}}$ is a design parameter, we get:

$$\dot{z}_i = \mathbf{\Lambda}_i z_i \text{ where } \begin{cases} \mathbf{\Lambda}_i := \begin{bmatrix} a & -b \\ b & a \end{bmatrix} - \mathbf{G} \mathbf{R}^{-1} \mathbf{G}^T \tilde{\mathbf{P}} \\ \tilde{\mathbf{P}} = \tilde{\mathbf{P}}^T := \begin{bmatrix} x & y \\ y & z \end{bmatrix} > 0 \end{cases} \quad (4.72)$$

Thus the closed-loop eigenvalues are the eigenvalues of matrix \mathbf{A}_i . Here the design process becomes a little bit more involved because parameters x , y and z of matrix $\tilde{\mathbf{P}}$ shall be chosen to meet the desired complex conjugate closed-loop eigenvalues λ_{Ki} and $\bar{\lambda}_{Ki}$ while minimizing the trace of $\tilde{\mathbf{P}}$ (indeed it can be shown that $\min(J_i) = \min(\text{trace}(\tilde{\mathbf{P}}))$). The design process has been described by Arar & Sawan⁴.

Alternatively, when the imaginary part of the shifted eigenvalues is preserved, that is when $\text{Im}(\lambda_{Ki}) = \text{Im}(\lambda_i)$ and $\text{Im}(\bar{\lambda}_{Ki}) = \text{Im}(\bar{\lambda}_i)$, then the design process can be simplified by using the mirror property underlined by Amin³ and presented in Section 4.5.1: given a controllable pair $(\mathbf{A}_i, \mathbf{G})$, a positive definite symmetric matrix \mathbf{R} and a positive real constant α , then the following algebraic Riccati equation has a unique positive definite solution $\tilde{\mathbf{P}} = \tilde{\mathbf{P}}^T > 0$:

$$(\mathbf{A}_i + \alpha \mathbb{I})^T \tilde{\mathbf{P}} + \tilde{\mathbf{P}} (\mathbf{A}_i + \alpha \mathbb{I}) - \tilde{\mathbf{P}} \mathbf{G} \mathbf{R}^{-1} \mathbf{G}^T \tilde{\mathbf{P}} = \mathbf{0} \quad (4.73)$$

Moreover the feedback control law $\underline{u} = -\mathbf{K}_i \underline{x}$ shift the pair of complex conjugate eigenvalues $(\lambda_i, \bar{\lambda}_i)$ of matrix \mathbf{A} to a pair of complex conjugate eigenvalues $(\lambda_{Ki}, \bar{\lambda}_{Ki})$ as follows, assuming $\alpha + \text{Re}(\lambda_i) \geq 0$:

$$\begin{cases} \mathbf{P}_i = \mathbf{C} \tilde{\mathbf{P}} \mathbf{C}^T \\ \mathbf{Q}_i = 2\alpha \mathbf{P}_i \\ \mathbf{K}_i = \mathbf{R}^{-1} \mathbf{G}^T \tilde{\mathbf{P}} \mathbf{C}^T \end{cases} \Rightarrow \begin{cases} \text{Re}(\lambda_{Ki}) = -(2\alpha + \text{Re}(\lambda_i)) \\ \text{Im}(\lambda_{Ki}) = \text{Im}(\lambda_i) \end{cases} \quad (4.74)$$

4.5.5 Sequential pole shifting via reduced-order models

The design process proposed by Amin³ to shift several eigenvalues recursively is the following:

1. Set $i = 1$ and $\mathbf{A}_1 = \mathbf{A}$.
2. Let λ_i be the eigenvalue of matrix \mathbf{A}_i which is desired to be shifted:
 - Assume that λ_i is real. We wish to shift λ_i to $\lambda_{Ki} \leq \lambda_i$. Then compute a (right) eigenvector \underline{v} of \mathbf{A}_i^T corresponding to λ_i . In other words \underline{v}^T is the *left* eigenvector of \mathbf{A}_i : $\underline{v}^T \mathbf{A}_i = \lambda_i \underline{v}^T$. Then compute \mathbf{C} , \mathbf{G} , α and \mathbf{A}_i defined by:

$$\begin{cases} \mathbf{C} = \underline{v} \\ \mathbf{G} = \mathbf{C}^T \mathbf{B} \\ \alpha = -\frac{\lambda_{Ki} + \lambda_i}{2} \geq 0 \text{ where } \lambda_{Ki} \leq \lambda_i \in \mathbb{R} \\ \mathbf{A}_i = \lambda_i \in \mathbb{R} \end{cases} \quad (4.75)$$

- Now assume that $\lambda_i = a + jb$ is complex. We wish to shift λ_i and $\bar{\lambda}_i$ to λ_{Ki} and $\bar{\lambda}_{Ki}$ where:

$$\begin{cases} \text{Re}(\lambda_{Ki}) \leq \text{Re}(\lambda_i) := a \\ \text{Im}(\lambda_{Ki}) = \text{Im}(\lambda_i) := b \end{cases} \quad (4.76)$$

⁴Abdul-Razzaq S. Arar, Mahmoud E. Sawan, Optimal pole placement with prescribed eigenvalues for continuous systems, Journal of the Franklin Institute, Volume 330, Issue 5, September 1993, Pages 985-994

This means that the shifted poles shall have the same imaginary parts than the original ones. Then compute (right) eigenvectors (v_1, v_2) of \mathbf{A}_i^T corresponding to λ_i and $\bar{\lambda}_i$. In other words (v_1^T, v_2^T) are the *left* eigenvectors of \mathbf{A}_i : $\begin{bmatrix} v_1^T \\ v_2^T \end{bmatrix} \mathbf{A}_i = \begin{bmatrix} \lambda_i & 0 \\ 0 & \bar{\lambda}_i \end{bmatrix} \begin{bmatrix} v_1^T \\ v_2^T \end{bmatrix}$. Then compute \mathbf{C} , \mathbf{G} , α and $\mathbf{\Lambda}_i$ defined by:

$$\begin{cases} v_1 = \bar{v}_2 \Rightarrow \mathbf{C} = [\operatorname{Re}(v_1) & \operatorname{Im}(v_1)] \\ \mathbf{G} = \mathbf{C}^T \mathbf{B} \\ \alpha = -\frac{\operatorname{Re}(\lambda_{K_i} + \lambda_i)}{2} \geq 0 \\ \lambda_i = a + jb \in \mathbb{C} \Rightarrow \mathbf{\Lambda}_i = \begin{bmatrix} a & -b \\ b & a \end{bmatrix} \end{cases} \quad (4.77)$$

3. Compute $\tilde{\mathbf{P}} = \tilde{\mathbf{P}}^T > 0$, which is defined as the unique positive definite solution of the following algebraic Riccati equation:

$$(\mathbf{\Lambda}_i + \alpha \mathbb{I})^T \tilde{\mathbf{P}} + \tilde{\mathbf{P}} (\mathbf{\Lambda}_i + \alpha \mathbb{I}) - \tilde{\mathbf{P}} \mathbf{G} \mathbf{R}^{-1} \mathbf{G}^T \tilde{\mathbf{P}} = \mathbf{0} \quad (4.78)$$

Alternatively, $\tilde{\mathbf{P}}$ can be defined as follows:

$$\tilde{\mathbf{P}} = \mathbf{X}^{-1} \quad (4.79)$$

where \mathbf{X} is the solution of the following Lyapunov equation:

$$(\mathbf{\Lambda}_i + \alpha \mathbb{I}) \mathbf{X} + \mathbf{X} (\mathbf{\Lambda}_i + \alpha \mathbb{I})^T = \mathbf{G} \mathbf{R}^{-1} \mathbf{G}^T \quad (4.80)$$

4. Compute \mathbf{P}_i , \mathbf{Q}_i and \mathbf{K}_i as follows:

$$\begin{cases} \mathbf{P}_i = \mathbf{C} \tilde{\mathbf{P}} \mathbf{C}^T \\ \mathbf{Q}_i = 2\alpha \mathbf{P}_i \\ \mathbf{K}_i = \mathbf{R}^{-1} \mathbf{G}^T \tilde{\mathbf{P}} \mathbf{C}^T \end{cases} \quad (4.81)$$

5. Set $i = i + 1$ and $\mathbf{A}_i = \mathbf{A}_{i-1} - \mathbf{B} \mathbf{K}_{i-1}$. Go to step 2 if some others open loop eigenvalues have to be shifted.

Once the loop is finished compute $\mathbf{P} = \sum_i \mathbf{P}_i$, $\mathbf{Q} = \sum_i \mathbf{Q}_i$ and $\mathbf{K} = \sum_i \mathbf{K}_i$. Gain \mathbf{K} is such that eigenvalues of $\mathbf{A} - \mathbf{B} \mathbf{K}$ are located to the desired values λ_{K_i} . Furthermore \mathbf{Q} is the weighting matrix for the state vector and \mathbf{P} is the positive definite solution of the corresponding algebraic Riccati equation.

4.6 Frequency domain approach

4.6.1 Non optimal pole assignment

We have seen in (3.70) that thanks to the Schur's formula the closed loop characteristic polynomial $\det(s\mathbb{I} - \mathbf{A} + \mathbf{B} \mathbf{K})$ reads as follows:

$$\det(s\mathbb{I} - \mathbf{A} + \mathbf{B} \mathbf{K}) = \det(s\mathbb{I} - \mathbf{A}) \det(\mathbb{I} + \mathbf{K} \Phi(s) \mathbf{B}) \quad (4.82)$$

Let $D(s) = \det(s\mathbb{I} - \mathbf{A})$ be the determinant of $\Phi(s)$, that is the plant characteristic polynomial, and $\mathbf{N}_{ol}(s) = \text{Adj}(s\mathbb{I} - \mathbf{A})\mathbf{B}$ be the adjugate matrix of $s\mathbb{I} - \mathbf{A}$ times matrix \mathbf{B} :

$$\Phi(s)\mathbf{B} = (s\mathbb{I} - \mathbf{A})^{-1}\mathbf{B} = \frac{\text{Adj}(s\mathbb{I} - \mathbf{A})\mathbf{B}}{\det(s\mathbb{I} - \mathbf{A})} := \frac{\mathbf{N}_{ol}(s)}{D(s)} \quad (4.83)$$

Consequently (4.82) reads:

$$\det(s\mathbb{I} - \mathbf{A} + \mathbf{BK}) = \det(D(s)\mathbb{I} + \mathbf{KN}_{ol}(s)) \quad (4.84)$$

As soon as λ_{K_i} is a desired closed loop eigenvalue then the following relationship holds:

$$\det(D(s)\mathbb{I} + \mathbf{KN}_{ol}(s))|_{s=\lambda_{K_i}} = 0 \quad (4.85)$$

Consequently it is desired that matrix $D(s)\mathbb{I} + \mathbf{KN}_{ol}(s)|_{s=\lambda_{K_i}}$ is singular. Let $\underline{\omega}_i$ be a vector belonging to the kernel of $D(s)\mathbb{I} + \mathbf{KN}_{ol}(s)|_{s=\lambda_{K_i}}$. Thus replacing s by λ_{K_i} we can write:

$$(D(\lambda_{K_i})\mathbb{I} + \mathbf{KN}_{ol}(\lambda_{K_i}))\underline{\omega}_i = \underline{0} \quad (4.86)$$

In order to get gain \mathbf{K} the preceding relationship is rewritten as follows:

$$\mathbf{KN}_{ol}(\lambda_{K_i})\underline{\omega}_i = -D(\lambda_{K_i})\underline{\omega}_i \quad (4.87)$$

This relationship does not lead to the value of gain \mathbf{K} as soon as $\mathbf{N}_{ol}(\lambda_{K_i})\underline{\omega}_i$ is a vector which is not invertible. Nevertheless assuming that n denotes the order of state matrix \mathbf{A} we can apply this relationship for the n desired closed loop eigenvalues. We get:

$$\mathbf{K} \begin{bmatrix} \underline{v}_{K_1} & \cdots & \underline{v}_{K_n} \end{bmatrix} = - \begin{bmatrix} \underline{p}_1 & \cdots & \underline{p}_n \end{bmatrix} \quad (4.88)$$

where vectors \underline{v}_{K_i} and \underline{p}_i are given by:

$$\begin{cases} \underline{v}_{K_i} = \mathbf{N}_{ol}(\lambda_{K_i})\underline{\omega}_i \\ \underline{p}_i = D(\lambda_{K_i})\underline{\omega}_i \end{cases} \quad (4.89)$$

We finally get the following expression of gain \mathbf{K} :

$$\mathbf{K} = - \begin{bmatrix} \underline{p}_1 & \cdots & \underline{p}_n \end{bmatrix} \begin{bmatrix} \underline{v}_{K_1} & \cdots & \underline{v}_{K_n} \end{bmatrix}^{-1} \quad (4.90)$$

4.6.2 Solving the algebraic Riccati equation

Let $D(s)$ be the open loop characteristic polynomial and $\beta(s)$ be the closed loop characteristic polynomial:

$$\begin{cases} D(s) = \det(s\mathbb{I} - \mathbf{A}) \\ \beta(s) = \det(s\mathbb{I} - \mathbf{A} + \mathbf{BK}) \end{cases} \quad (4.91)$$

We recall hereafter relationship (3.71) between the open loop and the closed loop eigenvalues:

$$\begin{cases} \beta(s) = \det(s\mathbb{I} - \mathbf{A}) \det(\mathbb{I} + \mathbf{K}\Phi(s)\mathbf{B}) \\ \Phi(s) = (s\mathbb{I} - \mathbf{A})^{-1} \end{cases} \quad (4.92)$$

Coupling the previous relationship with Kalman equality (3.76) and using the fact that $\det(\mathbf{XY}) = \det(\mathbf{X})\det(\mathbf{Y})$ it can be shown that:

$$\beta(s)\beta(-s) = D(s)D(-s)\det\left(\mathbb{I} + \mathbf{R}^{-1}(\Phi(-s)\mathbf{B})^T \mathbf{Q}(\Phi(s)\mathbf{B})\right) \quad (4.93)$$

Thus the stable roots (that are the roots with negative real part) λ_{K_i} of rational fraction $\det\left(\mathbf{R} + (\Phi(-s)\mathbf{B})^T \mathbf{Q}(\Phi(s)\mathbf{B})\right)$ are the closed loop eigenvalues:

$$\det\left(\mathbf{R} + (\Phi(-s)\mathbf{B})^T \mathbf{Q}(\Phi(s)\mathbf{B})\right)\Big|_{s=\lambda_{K_i}} = 0 \quad (4.94)$$

It is worth noticing that the denominator of $\det\left(\mathbf{R} + (\Phi(-s)\mathbf{B})^T \mathbf{Q}(\Phi(s)\mathbf{B})\right)$ is $D(s)D(-s)$.

Let $\mathbf{N}_{ol}(s)$ be the following polynomial matrix:

$$\mathbf{N}_{ol}(s) = \text{Adj}(s\mathbb{I} - \mathbf{A})\mathbf{B} \quad (4.95)$$

Then (4.90) can be used to get optimal gain \mathbf{K} as follows where n denotes the order of state matrix \mathbf{A} :

$$\mathbf{K} = -\left[\begin{array}{ccc} p_1 & \cdots & p_n \end{array}\right] \left(\left[\begin{array}{ccc} v_{K1} & \cdots & v_{Kn} \end{array}\right]\right)^{-1} \quad (4.96)$$

where vectors v_{K_i} and p_i are given as in the non optimal pole assignment problem:

$$\begin{cases} v_{K_i} = \mathbf{N}_{ol}(\lambda_{K_i})\underline{\omega}_i \\ p_i = D(\lambda_{K_i})\underline{\omega}_i \end{cases} \quad (4.97)$$

Nevertheless $m \times 1$ vectors $\underline{\omega}_i$ (m being the number of columns of input matrix \mathbf{B}) belongs to the kernel of matrix $D(-\lambda_{K_i})\mathbf{R}D(\lambda_{K_i}) + \mathbf{N}_{ol}^T(-\lambda_{K_i})\mathbf{Q}\mathbf{N}_{ol}(\lambda_{K_i})$. In other words vectors $\underline{\omega}_i$ satisfy the following relationship⁵:

$$(D(-\lambda_{K_i})\mathbf{R}D(\lambda_{K_i}) + \mathbf{N}_{ol}^T(-\lambda_{K_i})\mathbf{Q}\mathbf{N}_{ol}(\lambda_{K_i}))\underline{\omega}_i = \underline{0} \quad (4.98)$$

4.6.3 Poles assignment in optimal regulator using root locus

Let λ_i be an eigenvalue of the open loop state matrix \mathbf{A} corresponding to eigenvector v_i . This open loop eigenvalue will not be modified by state feedback gain \mathbf{K} by setting in (4.97) the $m \times 1$ vector p_i to zero and the $n \times 1$ eigenvector v_{K_i} to the open loop eigenvector v_i corresponding to eigenvalue λ_i :

$$\begin{cases} \mathbf{A}v_i = \lambda_i v_i \\ \mathbf{K} = \left[\cdots \underbrace{\mathbf{0}_{m \times 1}}_{i^{th} \text{ column}} \cdots \right] \left[\cdots \underbrace{v_i}_{i^{th} \text{ column}} \cdots \right]^{-1} \end{cases} \quad (4.99)$$

$$\Rightarrow (\mathbf{A} - \mathbf{BK})v_i = \lambda_i v_i$$

⁵L.S. Shieh, H.M. Dib, R.E. Yates, Sequential design of linear quadratic state regulators via the optimal root-locus techniques, IEE Proceedings D - Control Theory and Applications, Volume: 135, Issue: 4, July 1988, DOI: 10.1049/ip-d.1988.0040

Coming back to the general case, let $\underline{v}_1, \dots, \underline{v}_n$ be the eigenvectors of the open loop state matrix \mathbf{A} . Matrix \mathbf{V} is defined as follows:

$$\mathbf{V} = [\underline{v}_1 \quad \dots \quad \underline{v}_n] \quad (4.100)$$

Let $\lambda_1, \dots, \lambda_r$ be the $r \leq n$ eigenvalues that are desired to be kept invariant by state feedback gain \mathbf{K} and $\underline{v}_1, \dots, \underline{v}_r$ be the corresponding eigenvectors of state matrix \mathbf{A} . Similarly let $\lambda_{r+1}, \dots, \lambda_n$ be the $n - r$ eigenvalues that are desired to be changed by state feedback gain \mathbf{K} and $\underline{v}_{r+1}, \dots, \underline{v}_n$ be the corresponding eigenvectors of state matrix \mathbf{A} . Assuming that matrix \mathbf{V} is invertible, matrix \mathbf{M} is defined and split as follows where \mathbf{M}_r is an $r \times n$ matrix and \mathbf{M}_{n-r} is an $(n - r) \times n$ matrix:

$$\mathbf{M} = \mathbf{V}^{-1} = [\underline{v}_1 \quad \dots \quad \underline{v}_r \quad \underline{v}_{r+1} \quad \dots \quad \underline{v}_n]^{-1} = \begin{bmatrix} \mathbf{M}_r \\ \mathbf{M}_{n-r} \end{bmatrix} \quad (4.101)$$

Then it can be shown⁵ that once weighting matrix $\mathbf{R} = \mathbf{R}^T > 0$ is set the characteristic polynomial $\beta(s)$ of the closed loop transfer function is linked with the numerator and the denominator of the loop transfer function $\Phi(s)\mathbf{B} = (s\mathbb{I} - \mathbf{A})^{-1}\mathbf{B}$ as follows:

$$\begin{aligned} \Phi(s)\mathbf{B} &= (s\mathbb{I} - \mathbf{A})^{-1}\mathbf{B} = \frac{\text{Adj}(s\mathbb{I} - \mathbf{A})\mathbf{B}}{\det(s\mathbb{I} - \mathbf{A})} := \frac{\mathbf{N}_{ol}(s)}{D(s)} \\ \Rightarrow \beta(s)\beta(-s) &= D(s)D(-s) + k_p \underline{N}_{rl}(s)(\underline{N}_{rl}(-s))^T \end{aligned} \quad (4.102)$$

where:

$$\begin{cases} \underline{N}_{rl}(s) = \underline{q}_0^T \mathbf{M}_{n-r} \mathbf{N}_{ol}(s) (\mathbf{R}^{1/2})^{-1} \\ (\underline{N}_{rl}(-s))^T = (\underline{q}_0^T \mathbf{M}_{n-r} \mathbf{N}_{ol}(-s) (\mathbf{R}^{1/2})^{-1})^T \\ \mathbf{N}_{ol}(s) = \text{Adj}(s\mathbb{I} - \mathbf{A})\mathbf{B} \\ \mathbf{R} = \mathbf{R}^{1/2} \mathbf{R}^{1/2} \end{cases} \quad (4.103)$$

Matrix $\mathbf{R}^{1/2}$ is the root square of matrix \mathbf{R} . By getting the modal decomposition of matrix \mathbf{R} , that is $\mathbf{R} = \mathbf{V}\mathbf{D}\mathbf{V}^{-1}$ where \mathbf{V} is the matrix whose columns are the eigenvectors of \mathbf{R} and \mathbf{D} is the diagonal matrix whose diagonal elements are the corresponding positive eigenvalues, the square root $\mathbf{R}^{1/2}$ of \mathbf{R} is given by $\mathbf{R}^{1/2} = \mathbf{V}\mathbf{D}^{1/2}\mathbf{V}^{-1}$, where $\mathbf{D}^{1/2}$ is any diagonal matrix whose elements are the square root of the diagonal elements of \mathbf{D} ⁶.

Relationship (4.102) can be associated with root locus of the fictitious transfer function $G(s)G(-s) = \frac{\underline{N}_{rl}^T(s)\underline{N}_{rl}(-s)}{D(s)D(-s)}$ where fictitious gain k_p varies from 0 to ∞ . The arbitrary nonzero $(n - r) \times 1$ column vector \underline{q}_0 is used to shape the locus.

Furthermore whatever the closed loop eigenvalues $\lambda_{K1}, \dots, \lambda_{Kn}$ weighting matrix \mathbf{Q} has the following expression where k_p is the positive scalar obtained through the root locus:

$$\mathbf{Q} = k_p \mathbf{M}_{n-r}^T \begin{pmatrix} \underline{q}_0 & \underline{q}_0^T \end{pmatrix} \mathbf{M}_{n-r} \quad (4.104)$$

The following relationship also holds:

$$\mathbf{Q}\mathbf{M}_r = \mathbf{0} \quad (4.105)$$

⁶https://en.wikipedia.org/wiki/Square_root_of_a_matrix

4.7 Poles assignment in optimal regulator through matrix inequalities

In this section a method for designing linear quadratic regulator with prescribed closed loop pole is presented.

Let $\underline{\Lambda}_{cl} = \{\lambda_1, \lambda_2, \dots, \lambda_n\}$ be a set of prescribed closed loop eigenvalues, where $Re(\lambda_i) < 0$ and $\lambda_i \in \underline{\Lambda}_{cl}$ implies that the complex conjugate of λ_i , which is denoted λ_i^* , belongs also to $\underline{\Lambda}_{cl}$. The problem consists in finding a state feedback controller $u = -\mathbf{K}\underline{x}$ such that the eigenvalues of $\mathbf{A} - \mathbf{BK}$, which are denoted $\lambda(\mathbf{A} - \mathbf{BK})$, belongs to $\underline{\Lambda}_{cl}$:

$$\lambda(\mathbf{A} - \mathbf{BK}) = \underline{\Lambda}_{cl} \tag{4.106}$$

while minimizing the quadratic performance index $J(u(t))$ for some $\mathbf{Q} > 0$ and $\mathbf{R} > 0$.

$$J(u(t)) = \frac{1}{2} \int_0^\infty (\underline{x}^T(t)\mathbf{Q}\underline{x}(t) + u^T(t)\mathbf{R}u(t)) dt \tag{4.107}$$

We provide in that section the material written by He, Cai and Han⁷. Assume that (\mathbf{A}, \mathbf{B}) is controllable. Then, the pole assignment problem is solvable if and only if there exist two matrices $\mathbf{X}_1 \in \mathbb{R}^{n \times n}$ and $\mathbf{X}_2 \in \mathbb{R}^{n \times n}$ such that the following matrix inequalities are satisfied:

$$\begin{cases} \mathbf{F}^T \mathbf{X}_2^T \mathbf{X}_1 + \mathbf{X}_1^T \mathbf{X}_2 \mathbf{F} + \mathbf{X}_2^T \mathbf{B} \mathbf{R}^{-1} \mathbf{B}^T \mathbf{X}_2 \leq 0 \\ \mathbf{X}_1^T \mathbf{X}_2 = \mathbf{X}_2^T \mathbf{X}_1 > 0 \end{cases} \tag{4.108}$$

where \mathbf{F} is any matrix such that $\lambda(\mathbf{F}) = \underline{\Lambda}_{cl}$ and $(\mathbf{X}_1, \mathbf{X}_2)$ satisfies the following generalized Sylvester matrix equation⁸:

$$\mathbf{A}\mathbf{X}_1 - \mathbf{X}_1\mathbf{F} = \mathbf{B}\mathbf{R}^{-1}\mathbf{B}^T\mathbf{X}_2 \tag{4.109}$$

If $(\mathbf{X}_1, \mathbf{X}_2)$ is a feasible solution to the above two inequalities, then the weighting matrix \mathbf{Q} in the quadratic performance index $J(u(t))$ can be chosen as follows:

$$\mathbf{Q} = -\mathbf{A}^T \mathbf{X}_2 \mathbf{X}_1^{-1} - \mathbf{X}_2 \mathbf{F} \mathbf{X}_1^{-1} \tag{4.110}$$

In addition the solution the the corresponding Riccati Algebraic equation reads:

$$\mathbf{P} = \mathbf{X}_2 \mathbf{X}_1^{-1} \tag{4.111}$$

The starting point to get this result is the fact that there must exist an eigenvector matrix \mathbf{X} such that the following formula involving Hamiltonian matrix \mathbf{H} holds:

$$\mathbf{H}\mathbf{X} = \mathbf{X}\mathbf{F} \tag{4.112}$$

⁷Hua-Feng He, Guang-Bin Cai and Xiao-Jun Han, Optimal Pole Assignment of Linear Systems by the Sylvester Matrix Equations, Hindawi Publishing Corporation, Abstract and Applied Analysis, Volume 2014, Article ID 301375, <http://dx.doi.org/10.1155/2014/301375>

⁸An explicit solution to right factorization with application in eigenstructure assignment, Bin Zhou, Guangren Duan, Journal of Control Theory and Applications 08/2005; 3(3):275-279. DOI: 10.1007/s11768-005-0049-7

Splitting the $2n \times n$ matrix \mathbf{X} into 2 square $n \times n$ matrices \mathbf{X}_1 and \mathbf{X}_2 and using the expression of the $2n \times 2n$ Hamiltonian matrix \mathbf{H} leads to the following relationship:

$$\mathbf{X} = \begin{bmatrix} \mathbf{X}_1 \\ \mathbf{X}_2 \end{bmatrix} \Rightarrow \begin{bmatrix} \mathbf{A} & -\mathbf{B}\mathbf{R}^{-1}\mathbf{B}^T \\ -\mathbf{Q} & -\mathbf{A}^T \end{bmatrix} \begin{bmatrix} \mathbf{X}_1 \\ \mathbf{X}_2 \end{bmatrix} = \begin{bmatrix} \mathbf{X}_1 \\ \mathbf{X}_2 \end{bmatrix} \mathbf{F} \quad (4.113)$$

The preceding relationship is expanded as follows:

$$\begin{cases} \mathbf{A}\mathbf{X}_1 - \mathbf{B}\mathbf{R}^{-1}\mathbf{B}^T\mathbf{X}_2 = \mathbf{X}_1\mathbf{F} \\ -\mathbf{Q}\mathbf{X}_1 - \mathbf{A}^T\mathbf{X}_2 = \mathbf{X}_2\mathbf{F} \end{cases} \Leftrightarrow \begin{cases} \mathbf{A}\mathbf{X}_1 - \mathbf{X}_1\mathbf{F} = \mathbf{B}\mathbf{R}^{-1}\mathbf{B}^T\mathbf{X}_2 \\ \mathbf{Q} = -\mathbf{A}^T\mathbf{X}_2\mathbf{X}_1^{-1} - \mathbf{X}_2\mathbf{F}\mathbf{X}_1^{-1} \end{cases} \quad (4.114)$$

Since \mathbf{X}_1 is nonsingular matrix \mathbf{Q} is positive definite if and only if $\mathbf{X}_1^T\mathbf{Q}\mathbf{X}_1$ is positive definite. Using the first equation of (4.114) into the second one we get:

$$\begin{aligned} \mathbf{X}_1^T\mathbf{Q}\mathbf{X}_1 &= -\mathbf{X}_1^T\mathbf{A}^T\mathbf{X}_2 - \mathbf{X}_1^T\mathbf{X}_2\mathbf{F} \\ &= -(\mathbf{A}\mathbf{X}_1)^T\mathbf{X}_2 - \mathbf{X}_1^T\mathbf{X}_2\mathbf{F} \\ &= -(\mathbf{X}_1\mathbf{F} + \mathbf{B}\mathbf{R}^{-1}\mathbf{B}^T\mathbf{X}_2)^T\mathbf{X}_2 - \mathbf{X}_1^T\mathbf{X}_2\mathbf{F} \\ &= -(\mathbf{F}^T\mathbf{X}_2^T\mathbf{X}_1 + \mathbf{X}_1^T\mathbf{X}_2\mathbf{F} + \mathbf{X}_2^T\mathbf{B}\mathbf{R}^{-1}\mathbf{B}^T\mathbf{X}_2) \end{aligned} \quad (4.115)$$

Using the Schur complement and denoting $\mathbf{S} = \mathbf{X}_1^T\mathbf{X}_2$ the preceding relationship reads:

$$\mathbf{X}_1^T\mathbf{Q}\mathbf{X}_1 \geq 0 \Leftrightarrow \begin{bmatrix} \mathbf{F}^T\mathbf{S}^T + \mathbf{S}\mathbf{F} & \mathbf{X}_2^T\mathbf{B} \\ \mathbf{B}^T\mathbf{X}_2 & -\mathbf{R}^{-1} \end{bmatrix} \leq 0 \quad (4.116)$$

4.8 Model matching

4.8.1 Cross term in the performance index

Assume that the output $\underline{z}(t)$ of interest is expressed as a linear combination of state vector $\underline{x}(t)$ and control $u(t)$: $\underline{z}(t) = \mathbf{N}\underline{x}(t) + \mathbf{D}u(t)$. Thus the cost to be minimized reads:

$$\begin{aligned} \begin{cases} J(u(t)) = \frac{1}{2} \int_0^\infty \underline{z}^T(t)\underline{z}(t) + u^T(t)\mathbf{R}_1u(t) dt \\ \underline{z}(t) = \mathbf{N}\underline{x}(t) + \mathbf{D}u(t) \end{cases} \\ \Rightarrow J(u(t)) = \frac{1}{2} \int_0^\infty (\underline{x}^T(t)\mathbf{N}^T + u^T(t)\mathbf{D}^T) (\mathbf{N}\underline{x}(t) + \mathbf{D}u(t)) + u^T(t)\mathbf{R}_1u(t) dt \end{aligned} \quad (4.117)$$

Then we get a more general form of the quadratic performance index. Indeed the quadratic performance index can be rewritten as:

$$\begin{aligned} J(u(t)) &= \frac{1}{2} \int_0^\infty \begin{bmatrix} \underline{x} \\ \underline{u} \end{bmatrix}^T \begin{bmatrix} \mathbf{Q} & \mathbf{N} \\ \mathbf{N}^T & \mathbf{R} \end{bmatrix} \begin{bmatrix} \underline{x} \\ \underline{u} \end{bmatrix} dt \\ &= \frac{1}{2} \int_0^\infty (\underline{x}^T(t)\mathbf{Q}\underline{x}(t) + u^T(t)\mathbf{R}u(t)) + 2\underline{x}^T(t)\mathbf{N}u(t) dt \end{aligned} \quad (4.118)$$

Where:

$$\begin{cases} \mathbf{Q} = \mathbf{N}^T\mathbf{N} \\ \mathbf{R} = \mathbf{D}^T\mathbf{D} + \mathbf{R}_1 \\ \mathbf{N} = \mathbf{N}^T\mathbf{D} \end{cases} \quad (4.119)$$

It can be seen that:

$$\underline{x}^T(t)\mathbf{Q}\underline{x}(t) + u^T(t)\mathbf{R}u(t) + 2\underline{x}^T(t)\mathbf{N}u(t) = \underline{x}^T(t)\mathbf{Q}_m\underline{x}(t) + v^T(t)\mathbf{R}v(t) \quad (4.120)$$

Where:

$$\begin{cases} \mathbf{Q}_m = \mathbf{Q} - \mathbf{N}\mathbf{R}^{-1}\mathbf{N}^T \\ v(t) = u(t) + \mathbf{R}^{-1}\mathbf{N}^T\underline{x}(t) \end{cases} \quad (4.121)$$

Hence cost (4.118) can be rewritten as:

$$J(u(t)) = \frac{1}{2} \int_0^\infty \underline{x}^T(t)\mathbf{Q}_m\underline{x}(t) + v^T(t)\mathbf{R}v(t) dt \quad (4.122)$$

And the plant dynamics $\dot{\underline{x}} = \mathbf{A}\underline{x}(t) + \mathbf{B}u(t)$ is modified as follows:

$$\begin{aligned} \dot{\underline{x}} &= \mathbf{A}\underline{x}(t) + \mathbf{B}u(t) \\ &= \mathbf{A}\underline{x}(t) + \mathbf{B}(v(t) - \mathbf{R}^{-1}\mathbf{N}^T\underline{x}(t)) \\ &= \mathbf{A}_m\underline{x}(t) + \mathbf{B}v(t) \end{aligned} \quad (4.123)$$

where $\mathbf{A}_m = \mathbf{A} - \mathbf{B}\mathbf{R}^{-1}\mathbf{N}^T$

Assuming that \mathbf{Q}_m (which is symmetric) is positive semi-definite, we then get a standard LQR problem for which the optimal state feedback control law is given from (3.8):

$$\begin{cases} v(t) = -\mathbf{R}^{-1}\mathbf{B}^T\mathbf{P}\underline{x}(t) \\ v(t) = u(t) + \mathbf{R}^{-1}\mathbf{N}^T\underline{x}(t) \end{cases} \Rightarrow \begin{cases} u(t) = -\mathbf{K}\underline{x}(t) \\ \mathbf{K} = \mathbf{R}^{-1}(\mathbf{P}\mathbf{B} + \mathbf{N})^T \end{cases} \quad (4.124)$$

Where matrix \mathbf{P} is the positive semi-definite matrix which solves the following *algebraic Riccati equation* (see (3.7)):

$$\mathbf{P}\mathbf{A}_m + \mathbf{A}_m^T\mathbf{P} - \mathbf{P}\mathbf{B}\mathbf{R}^{-1}\mathbf{B}^T\mathbf{P} + \mathbf{Q}_m = \mathbf{0} \quad (4.125)$$

It is worth noticing that robustness properties of the LQ state feedback are lost if the cost to be minimized contains a state-control cross term as it is the case here.

4.8.2 Implicit reference model

Let \mathbf{A}_r be the desired closed loop system matrix of the system. In that section we consider the problem to find control $u(t)$ which minimizes the norm of the following error vector $e(t)$:

$$e(t) = \dot{\underline{x}}(t) - \mathbf{A}_r\underline{x}(t) \quad (4.126)$$

The cost to be minimized is the following:

$$\begin{aligned} J(u(t)) &= \frac{1}{2} \int_0^\infty e^T(t)e(t) dt \\ &= \frac{1}{2} \int_0^\infty (\dot{\underline{x}}(t) - \mathbf{A}_r\underline{x}(t))^T (\dot{\underline{x}}(t) - \mathbf{A}_r\underline{x}(t)) dt \end{aligned} \quad (4.127)$$

Expanding $\dot{\underline{x}}(t)$ we get:

$$\begin{aligned} J(u(t)) &= \frac{1}{2} \int_0^\infty (\mathbf{A}\underline{x}(t) + \mathbf{B}u(t) - \mathbf{A}_r\underline{x}(t))^T (\mathbf{A}\underline{x}(t) + \mathbf{B}u(t) - \mathbf{A}_r\underline{x}(t)) dt \\ &= \frac{1}{2} \int_0^\infty ((\mathbf{A} - \mathbf{A}_r)\underline{x}(t) + \mathbf{B}u(t))^T ((\mathbf{A} - \mathbf{A}_r)\underline{x}(t) + \mathbf{B}u(t)) dt \end{aligned} \quad (4.128)$$

We get a cost to be minimized which contains a state-control cross term:

$$J(u(t)) = \frac{1}{2} \int_0^\infty (\underline{x}^T(t) \mathbf{Q} \underline{x}(t) + u^T(t) \mathbf{R} u(t)) + 2 \underline{x}^T(t) \mathbf{N} u(t) dt \quad (4.129)$$

Where:

$$\begin{cases} \mathbf{Q} = (\mathbf{A} - \mathbf{A}_r)^T (\mathbf{A} - \mathbf{A}_r) \\ \mathbf{R} = \mathbf{B}^T \mathbf{B} \\ \mathbf{N} = (\mathbf{A} - \mathbf{A}_r)^T \mathbf{B} \end{cases} \quad (4.130)$$

Then we can re-use the results of section 4.8.1. Let \mathbf{P} be the positive semi-definite matrix which solves the following *algebraic Riccati* equation:

$$\mathbf{P} \mathbf{A}_m + \mathbf{A}_m^T \mathbf{P} - \mathbf{P} \mathbf{B} \mathbf{R}^{-1} \mathbf{B}^T \mathbf{P} + \mathbf{Q}_m = \mathbf{0} \quad (4.131)$$

Where:

$$\begin{cases} \mathbf{Q}_m = \mathbf{Q} - \mathbf{N} \mathbf{R}^{-1} \mathbf{N}^T \\ \mathbf{A}_m = \mathbf{A} - \mathbf{B} \mathbf{R}^{-1} \mathbf{N}^T \\ v(t) = u(t) + \mathbf{R}^{-1} \mathbf{N}^T \underline{x}(t) \end{cases} \quad (4.132)$$

The stabilizing control $u(t)$ is then defined in a similar fashion than (4.124):

$$\begin{cases} v(t) = -\mathbf{R}^{-1} \mathbf{B}^T \mathbf{P} \underline{x}(t) \\ v(t) = u(t) + \mathbf{R}^{-1} \mathbf{N}^T \underline{x}(t) \end{cases} \Rightarrow \begin{cases} u(t) = -\mathbf{K} \underline{x}(t) \\ \mathbf{K} = \mathbf{R}^{-1} (\mathbf{P} \mathbf{B} + \mathbf{N})^T \end{cases} \quad (4.133)$$

It is worth noticing that robustness properties of the LQ state feedback are lost if the cost to be minimized contains a state-control cross term as it is the case here.

Furthermore let \mathbf{V} be the change of basis matrix to the Jordan form \mathbf{A}_r of the desired closed loop state matrix \mathbf{A}_r :

$$\mathbf{A}_r = \mathbf{V}^{-1} \mathbf{A}_r \mathbf{V} \quad (4.134)$$

Let \mathbf{A}_{cl} be the state matrix of the closed loop which is written using matrix \mathbf{V} as follows :

$$\dot{\underline{x}}(t) = \mathbf{A}_{cl} \underline{x}(t) = \mathbf{V} \mathbf{A}_{cl} \mathbf{V}^{-1} \underline{x}(t) \quad (4.135)$$

Assuming that the desired Jordan form \mathbf{A}_r is a diagonal matrix and using the fact $\mathbf{V}^{-1} = \mathbf{V}^T$ the product $e^T(t) e(t)$ in (4.127) reads as follows:

$$\begin{aligned} e^T(t) e(t) &= \underline{x}^T(t) (\mathbf{A}_{cl} - \mathbf{A}_r)^T (\mathbf{A}_{cl} - \mathbf{A}_r) \underline{x}(t) \\ &= \underline{x}^T(t) \mathbf{V} (\mathbf{A}_{cl} - \mathbf{A}_r)^T (\mathbf{A}_{cl} - \mathbf{A}_r) \mathbf{V}^T \underline{x}(t) \end{aligned} \quad (4.136)$$

From the preceding equation it is clear that minimizing the cost $J(u(t)) = \frac{1}{2} \int_0^\infty e^T(t) e(t) dt$ consists in finding the control $u(t)$ which minimizes the gap between the desired eigenvalues (which are set in \mathbf{A}_r) and the actual eigenvalues of the closed loop.

4.9 Frequency shaped LQ control

Often system performances are specified in the frequency domain. The purpose of this section is to shift the time domain nature of the LQR problem in the frequency domain as proposed by Gupta in 1980⁹. This is done thanks to Parseval's theorem which enables to write the performance index J to be minimized as follows, where w represents frequency (in *rad/sec*):

$$\begin{aligned} J &= \int_0^\infty (\underline{x}^T(t)\mathbf{Q}\underline{x}(t) + u^T(t)\mathbf{R}u(t)) dt \\ &= \frac{1}{2\pi} \int_0^\infty \underline{x}^T(-j\omega)\mathbf{Q}\underline{x}(j\omega) + u^T(-j\omega)\mathbf{R}u(j\omega)dw \end{aligned} \quad (4.137)$$

Then constant weighting matrices \mathbf{Q} and \mathbf{R} are modified to be function of the frequency w in order to place distinct penalties on the state and control cost at various frequencies:

$$\begin{cases} \mathbf{Q} = \mathbf{Q}(w) = \mathbf{W}_q^T(-j\omega)\mathbf{W}_q(j\omega) \\ \mathbf{R} = \mathbf{R}(w) = \mathbf{W}_r^T(-j\omega)\mathbf{W}_r(j\omega) \end{cases} \quad (4.138)$$

For the existence of the solution of the LQ regulator, matrix $\mathbf{R}(w)$ shall be of full rank. Since we seek to minimize the quadratic cost J , then large terms in the integrand incur greater penalties than small terms and more effort is exerted to make them small. Thus if there is for example an high frequency region where the model of the plant presents unmodeled dynamics and if the control weight $\mathbf{W}_r(j\omega)$ is chosen to have large magnitude over this region then the resulting controller would not exert substantial energy in this region. This in turn would limit the controller bandwidth.

Let us define the following vectors to carry out the dynamics of the weights in the frequency domain, where s denotes the Laplace variable:

$$\begin{cases} \underline{z}(s) = \mathbf{W}_q(s)\underline{x}(s) \\ v(s) = \mathbf{W}_r(s)u(s) \end{cases} \quad (4.139)$$

In order to simplify the process of selecting useful weights, it is common to choose weighting matrices to be scalar functions multiplying the identity matrix:

$$\begin{cases} \mathbf{W}_q(s) = w_q(s)\mathbb{I} \\ \mathbf{W}_r(s) = w_r(s)\mathbb{I} \end{cases} \quad (4.140)$$

The performance index J to be minimized in (4.137) turns to be:

$$J = \frac{1}{2\pi} \int_0^\infty \underline{z}^T(-j\omega)\underline{z}(j\omega) + v^T(-j\omega)v(j\omega)dw \quad (4.141)$$

Using Parseval's theorem we get in the time domain:

$$J = \int_0^\infty \underline{z}^T(t)\underline{z}(t) + v^T(t)v(t) dt \quad (4.142)$$

⁹Frequency-Shaped Cost Functionals: Extension of Linear Quadratic Gaussian Design Methods, Narendra K. Gupta, Journal of Guidance Control and Dynamics. 11/1980; 3(6):529-535. DOI: 10.2514/3.19722

Let the state space model of the first equation of (4.139) be the following, where $\underline{z}(t)$ is the output and $\underline{x}(t)$ the input of the following MIMO system:

$$\begin{cases} \dot{\chi}_q(t) = \mathbf{A}_q \chi_q(t) + \mathbf{B}_q \underline{x}(t) \\ \underline{z}(t) = \mathbf{N}_q \chi_q(t) + \mathbf{D}_q \underline{x}(t) \end{cases} \quad (4.143)$$

$$\Rightarrow \underline{z}(s) = \left(\mathbf{N}_q (sI - \mathbf{A}_q)^{-1} \mathbf{B}_q + \mathbf{D}_q \right) \underline{x}(s) = \mathbf{W}_q(s) \underline{x}(s)$$

Similarly, let the state space model of the second equation of (4.139) be the following, where $v(t)$ is the output and $u(t)$ the input of the following MIMO system:

$$\begin{cases} \dot{\chi}_r(t) = \mathbf{A}_r \chi_r(t) + \mathbf{B}_r u(t) \\ v(t) = \mathbf{N}_r \chi_r(t) + \mathbf{D}_r u(t) \end{cases} \quad (4.144)$$

$$\Rightarrow v(s) = \left(\mathbf{N}_r (sI - \mathbf{A}_r)^{-1} \mathbf{B}_r + \mathbf{D}_r \right) u(s) = \mathbf{W}_r(s) u(s)$$

Then it can be shown from (4.143) and (4.144) that:

$$\begin{aligned} \underline{z}^T(t) \underline{z}(t) + v^T(t) v(t) &= (\mathbf{N}_q \chi_q(t) + \mathbf{D}_q \underline{x}(t))^T (\mathbf{N}_q \chi_q(t) + \mathbf{D}_q \underline{x}(t)) \\ &\quad + (\mathbf{N}_r \chi_r(t) + \mathbf{D}_r u(t))^T (\mathbf{N}_r \chi_r(t) + \mathbf{D}_r u(t)) \end{aligned} \quad (4.145)$$

That is:

$$\begin{aligned} \underline{z}^T(t) \underline{z}(t) + v^T(t) v(t) &= [\underline{x}^T(t) \quad \chi_q^T(t) \quad \chi_r(t)^T] \mathbf{Q}_f \begin{bmatrix} \underline{x}(t) \\ \chi_q(t) \\ \chi_r(t) \end{bmatrix} \\ &\quad + 2 [\underline{x}^T(t) \quad \chi_q^T(t) \quad \chi_r(t)^T] \mathbf{N}_f u(t) + u^T(t) \mathbf{R}_f u(t) \end{aligned} \quad (4.146)$$

Where:

$$\left\{ \begin{array}{l} \mathbf{Q}_f = \begin{bmatrix} \mathbf{D}_q^T \mathbf{D}_q & \mathbf{D}_q^T \mathbf{N}_q & 0 \\ \mathbf{N}_q^T \mathbf{D}_q & \mathbf{N}_q^T \mathbf{N}_q & 0 \\ 0 & 0 & \mathbf{N}_r^T \mathbf{N}_r \end{bmatrix} \\ \mathbf{N}_f = \begin{bmatrix} 0 \\ 0 \\ \mathbf{N}_r^T \mathbf{D}_r \end{bmatrix} \\ \mathbf{R}_f = \mathbf{D}_r^T \mathbf{D}_r \end{array} \right. \quad (4.147)$$

Then define the augmented state vector $\underline{x}_a(t)$:

$$\underline{x}_a(t) = \begin{bmatrix} \underline{x}(t) \\ \chi_q(t) \\ \chi_r(t) \end{bmatrix} \quad (4.148)$$

And the augmented state space model:

$$\dot{\underline{x}}_a(t) = \frac{d}{dt} \begin{bmatrix} \underline{x}(t) \\ \chi_q(t) \\ \chi_r(t) \end{bmatrix} = \mathbf{A}_a \underline{x}_a(t) + \mathbf{B}_a u(t) \quad (4.149)$$

Where:

$$\left\{ \begin{array}{l} \mathbf{A}_a = \begin{bmatrix} \mathbf{A} & 0 & 0 \\ \mathbf{B}_q & \mathbf{A}_q & 0 \\ 0 & 0 & \mathbf{A}_r \end{bmatrix} \\ \mathbf{B}_a = \begin{bmatrix} \mathbf{B} \\ 0 \\ \mathbf{B}_r \end{bmatrix} \end{array} \right. \quad (4.150)$$

Using (4.146) the performance index J defined in (4.142) is written as follows:

$$J = \int_0^{\infty} \underline{x}_a^T(t) \mathbf{Q}_f \underline{x}_a(t) + 2 \underline{x}_a(t) \mathbf{N}_f u(t) + u(t)^T \mathbf{R}_f u(t) dt \quad (4.151)$$

As far as cross term in the performance index J appears results obtained in section 4.8.1 will be used: The algebraic Riccati equation (4.125) reads as follows:

$$\mathbf{P} \mathbf{A}_m + \mathbf{A}_m^T \mathbf{P} - \mathbf{P} \mathbf{B}_a \mathbf{R}^{-1} \mathbf{B}_a^T \mathbf{P} + \mathbf{Q}_m = \mathbf{0} \quad (4.152)$$

Where:

$$\left\{ \begin{array}{l} \mathbf{Q}_m = \mathbf{Q}_f - \mathbf{N}_f \mathbf{R}_f^{-1} \mathbf{N}_f^T \\ \mathbf{A}_m = \mathbf{A}_a - \mathbf{B}_a \mathbf{R}_f^{-1} \mathbf{N}_f^T \end{array} \right. \quad (4.153)$$

Denoting by \mathbf{P} the positive semi-definite matrix which solves the *algebraic Riccati* equation (4.152), the stabilizing control $u(t)$ is then defined in a similar fashion than (4.124):

$$\left\{ \begin{array}{l} u(t) = -\mathbf{K} \underline{x}(t) \\ \mathbf{K} = \mathbf{R}_f^{-1} (\mathbf{P} \mathbf{B}_a + \mathbf{N}_f)^T \end{array} \right. \quad (4.154)$$

4.10 Optimal transient stabilization

We provide in that section the material written by L. Qiu and K. Zhou¹⁰. Let's consider the feedback system for stabilization system in Figure 4.2 where $G(s)$ is the plant and $K(s)$ is the controller: The known transfer function $G(s)$ of the plant is assumed to be strictly proper with a *monic polynomial* on the denominator (a *monic polynomial* is a polynomial in which the leading coefficient (the nonzero coefficient of highest degree) is equal to 1):

$$G(s) = \frac{N(s)}{D(s)} = \frac{b_{n-1}s^{n-1} + \dots + b_1s + b_0}{s^n + a_{n-1}s^{n-1} + \dots + a_1s + a_0} \quad (4.155)$$

Similarly the unknown transfer function $K(s)$ of the controller is assumed to be strictly proper with a monic polynomial on the denominator:

$$K(s) = \frac{q(s)}{p(s)} = \frac{q_{m-1}s^{m-1} + \dots + q_1s + q_0}{s^m + p_{m-1}s^{m-1} + \dots + p_1s + p_0} \quad (4.156)$$

¹⁰Preclassical Tools for Postmodern Control, An optimal And Robust Control Theory For Undergraduate Education, Li Qiu and Kemin Zhou, IEEE Control Systems Magazine, August 2013

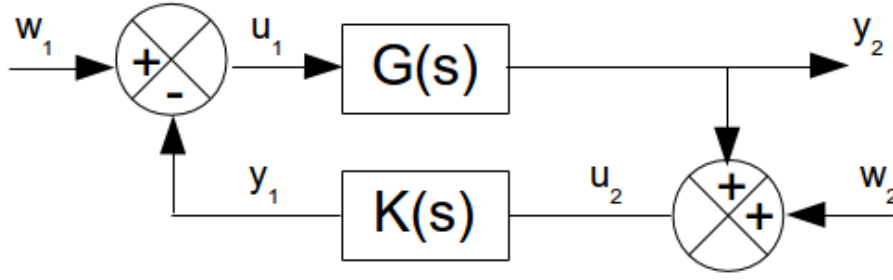

Figure 4.2: Feedback system for stabilization

The closed loop characteristic polynomial $\beta(s)$ is:

$$\begin{aligned}\beta(s) &= N(s)q(s) + D(s)p(s) \\ &= s^{n+m} + \beta_{n+m-1}s^{n+m-1} + \dots + \beta_1s + \beta_0\end{aligned}\quad (4.157)$$

For given coprime polynomials $N(s)$ and $D(s)$ as well as an arbitrarily chosen closed loop characteristic polynomial $\beta(s)$ the expression of $p(s)$ and $q(s)$ amounts to solving the following Diophantine equation:

$$\beta(s) = N(s)q(s) + D(s)p(s) \quad (4.158)$$

This linear equation in the coefficients of $p(s)$ and $q(s)$ has solution for arbitrary $\beta(s)$ if and only if $m \geq n$. The solution is unique if and only if $m = n$. Now consider the following performance measure $J(\rho, \mu)$ where ρ and μ are positive number to give relative weights to outputs $y_1(t)$ and $y_2(t)$ and to inputs $w_1(t)$ and $w_2(t)$ respectively and $\delta(t)$ is the Dirac delta function:

$$\begin{aligned}J(\rho, \mu) &= \frac{1}{2} \int_0^\infty y_1^2(t) + \rho y_2^2(t) dt \Big|_{\substack{w_1(t) = \mu\delta(t) \\ w_2(t) = 0}} \\ &\quad + \frac{1}{2} \int_0^\infty y_1^2(t) + \rho y_2^2(t) dt \Big|_{\substack{w_1(t) = 0 \\ w_2(t) = \delta(t)}}\end{aligned}\quad (4.159)$$

The design procedure to obtain the controller which minimizes performance measure $J(\rho, \mu)$ is the following:

- Find polynomial $d_\mu(s)$ (also called *spectral factor*) which is formed with the n roots with negative real parts of $D(s)D(-s) + \mu^2N(s)N(-s)$:

$$D(s)D(-s) + \mu^2N(s)N(-s) = d_\mu(s)d_\mu(-s) \quad (4.160)$$

- Find polynomial $d_\rho(s)$ (also called *spectral factor*) which is formed with the n roots with negative real parts of $D(s)D(-s) + \rho N(s)N(-s)$:

$$D(s)D(-s) + \rho N(s)N(-s) = d_\rho(s)d_\rho(-s) \quad (4.161)$$

-
- Then the optimal controller $K(s) = q(s)/p(s)$ is the unique n^{th} order strictly proper transfer function such that:

$$D(s)p(s) + N(s)q(s) = d_\mu(s)d_\rho(s) \quad (4.162)$$

Chapter 5

Linear Quadratic Tracker (LQT)

5.1 Introduction

The regulator problem that has been tackled in the previous chapters is in fact a special case of a wider class of problems where the outputs of the system are required to follow a desired trajectory in some optimal sense. As underlined in the book of *Anderson and Moore* trajectory following problems can be conveniently separated into three different problems which depend on the nature of the desired output trajectory:

- If the plant outputs are to follow a class of desired trajectories, for example all polynomials up to certain order, the problem is referred to as a servo (servomechanism) problem;
- When the plant outputs are to follow the response of another plant (or model) the problem is referred to as model following problems;
- If the desired output trajectory is a particular prescribed function of time, the problem is called a tracking problem.

This chapter is devoted to the presentation of some results common to all three of these problems, with a particular attention being given on the tracking problem.

5.2 Optimal LQ tracker

5.2.1 Finite horizon Linear Quadratic Tracker

We will consider in this section the following linear system, where $\underline{x}(t)$ is the state vector, $u(t)$ the control, $\underline{r}(t)$ a reference output (which is omitted in the regulator problem, meaning that $\mathbf{G} = 0$ in that case) and $\underline{y}(t)$ the controlled output (that is the output of interest):

$$\begin{cases} \dot{\underline{x}}(t) = \mathbf{A}\underline{x}(t) + \mathbf{B}u(t) + \mathbf{G}\underline{r}(t) \\ \underline{y}(t) = \mathbf{C}\underline{x}(t) \end{cases} \quad (5.1)$$

It is now desired to find an optimal control law in such a way that the controlled output $\underline{y}(t)$ tracks or follows a reference output $\underline{r}(t)$. Hence the

performance index is defined as:

$$J(u(t)) = \frac{1}{2} \underline{e}^T(t_f) \mathbf{S} \underline{e}(t_f) + \frac{1}{2} \int_0^{t_f} \underline{e}^T(t) \mathbf{Q} \underline{e}(t) + u^T(t) \mathbf{R} u(t) dt \quad (5.2)$$

Where $\underline{e}(t)$ is the trajectory error defined as:

$$\underline{e}(t) = \underline{r}(t) - \underline{y}(t) = \mathbf{M} \underline{r}(t) - \mathbf{C} \underline{x}(t) \quad (5.3)$$

The Hamiltonian H is then defined as:

$$H(\underline{x}, u, \lambda) = \frac{1}{2} \underline{e}^T(t) \mathbf{Q} \underline{e}(t) + \frac{1}{2} u^T(t) \mathbf{R} u(t) + \lambda^T(t) (\mathbf{A} \underline{x}(t) + \mathbf{B} u(t) + \mathbf{G} \underline{r}(t)) \quad (5.4)$$

The optimality condition (1.71) yields:

$$\frac{\partial H}{\partial u} = 0 = \mathbf{R} u(t) + \mathbf{B}^T \lambda(t) \Rightarrow u(t) = -\mathbf{R}^{-1} \mathbf{B}^T \lambda(t) \quad (5.5)$$

Equation (1.62) yields:

$$\begin{aligned} \dot{\lambda}(t) &= -\frac{\partial H}{\partial \underline{x}} \\ &= -\left(\underline{e}^T(t) \mathbf{Q} \frac{\partial \underline{e}}{\partial \underline{x}} + \lambda^T(t) \mathbf{A} \right)^T \\ &= -\left(-(\mathbf{M} \underline{r}(t) - \mathbf{C} \underline{x}(t))^T \mathbf{Q} \mathbf{C} + \lambda^T(t) \mathbf{A} \right)^T \\ \Leftrightarrow \dot{\lambda}(t) &= -\mathbf{A}^T \lambda(t) - \mathbf{C}^T \mathbf{Q} \mathbf{C} \underline{x}(t) + \mathbf{C}^T \mathbf{Q} \mathbf{M} \underline{r}(t) \end{aligned} \quad (5.6)$$

With the terminal condition (1.63):

$$\begin{aligned} \lambda(t_f) &= \frac{\partial \mathbf{G}(\underline{x}(t_f))}{\partial \underline{x}(t_f)} \\ &= \frac{\partial (\mathbf{M} \underline{r}(t_f) - \mathbf{C} \underline{x}(t_f))^T \mathbf{S} \underline{e}(t_f)}{\partial \underline{x}(t_f)} \\ \Leftrightarrow \lambda(t_f) &= \mathbf{C}^T \mathbf{S} (\mathbf{C} \underline{x}(t_f) - \mathbf{M} \underline{r}(t_f)) \end{aligned} \quad (5.7)$$

In order to determine the closed loop control law, the expression (2.74) is modified as follows:

$$\lambda(t) = \mathbf{P}(t) \underline{x}(t) - g(t) \quad (5.8)$$

Where $g(t)$ is to be determined. Using (5.8), the terminal conditions (5.7) can be written as:

$$\mathbf{P}(t_f) \underline{x}(t_f) - g(t_f) = \mathbf{C}^T \mathbf{S} (\mathbf{C} \underline{x}(t_f) - \mathbf{M} \underline{r}(t_f)) \quad (5.9)$$

Which implies:

$$\begin{cases} \mathbf{P}(t_f) = \mathbf{C}^T \mathbf{S} \mathbf{C} \\ g(t_f) = \mathbf{C}^T \mathbf{S} \mathbf{M} \underline{r}(t_f) \end{cases} \quad (5.10)$$

Then from (5.5) and (5.8) the control law is:

$$\begin{aligned} u(t) &= -\mathbf{R}^{-1} \mathbf{B}^T \lambda(t) \\ &= -\mathbf{R}^{-1} \mathbf{B}^T (\mathbf{P}(t) \underline{x}(t) - g(t)) \\ &= -\mathbf{R}^{-1} \mathbf{B}^T \mathbf{P}(t) \underline{x}(t) + \mathbf{R}^{-1} \mathbf{B}^T g(t) \end{aligned} \quad (5.11)$$

From the preceding equation it is clear that the optimal control is the sum of two components:

- A state feedback component: $-\mathbf{R}^{-1}\mathbf{B}^T\mathbf{P}(t)\underline{x}(t) = -\mathbf{K}_x(t)\underline{x}(t)$
- A feedforward component: $\mathbf{R}^{-1}\mathbf{B}^T g(t)$

In addition, differentiating (5.8) yields:

$$\dot{\lambda}(t) = \dot{\mathbf{P}}(t)\underline{x}(t) + \mathbf{P}(t)\dot{\underline{x}}(t) - \dot{g}(t) \quad (5.12)$$

Using (5.6) yields:

$$\begin{aligned} -\mathbf{A}^T\lambda(t) - \mathbf{C}^T\mathbf{Q}\mathbf{C}\underline{x}(t) + \mathbf{C}^T\mathbf{Q}\mathbf{M}\underline{r}(t) = \\ \dot{\mathbf{P}}(t)\underline{x}(t) + \mathbf{P}(t)(\mathbf{A}\underline{x}(t) + \mathbf{B}u(t) + \mathbf{G}\underline{r}(t)) - \dot{g}(t) \end{aligned} \quad (5.13)$$

Using (5.1), (5.8) and (5.11) to express $u(t)$ as a function of $\underline{x}(t)$ and $g(t)$ we finally get:

$$\begin{aligned} \left(\dot{\mathbf{P}}(t) + \mathbf{A}^T\mathbf{P}(t) + \mathbf{P}(t)\mathbf{A} - \mathbf{P}(t)\mathbf{B}\mathbf{R}^{-1}\mathbf{B}^T\mathbf{P}(t) + \mathbf{C}^T\mathbf{Q}\mathbf{C} \right) \underline{x}(t) \\ - \left(\dot{g}(t) + (\mathbf{C}^T\mathbf{Q}\mathbf{M} - \mathbf{P}(t)\mathbf{G})\underline{r}(t) + (\mathbf{A}^T - \mathbf{P}(t)\mathbf{B}\mathbf{R}^{-1}\mathbf{B}^T)g(t) \right) = \underline{0} \end{aligned} \quad (5.14)$$

The solution of (5.14) can be obtained by solving the preceding equation as two separate problems:

$$\begin{cases} -\dot{\mathbf{P}}(t) = \mathbf{A}^T\mathbf{P}(t) + \mathbf{P}(t)\mathbf{A} - \mathbf{P}(t)\mathbf{B}\mathbf{R}^{-1}\mathbf{B}^T\mathbf{P}(t) + \mathbf{C}^T\mathbf{Q}\mathbf{C} \\ -\dot{g}(t) = (\mathbf{A}^T - \mathbf{P}(t)\mathbf{B}\mathbf{R}^{-1}\mathbf{B}^T)g(t) + (\mathbf{C}^T\mathbf{Q}\mathbf{M} - \mathbf{P}(t)\mathbf{G})\underline{r}(t) \end{cases} \quad (5.15)$$

Obviously, we recognize in the first equation the Riccati equation (2.80) with $\mathbf{C} = \mathbf{I}$. The second equation defines the feedforward gain $g(t)$. Equations (5.15) are solved backward: the time is reversed by setting $\tau = t_f - t$ (thus the minus signs to the left of equalities (5.15) are omitted) and equations (5.10) are used as initial condition. The solution is then reversed in time to obtain $\mathbf{P}(t)$ and $g(t)$. Alternatively, we can use the fact that the first equation of (5.15) is the differential Riccati equation which has been studied in section 2.6.2. Using (2.109), (2.116) and (2.120) we get:

$$\mathbf{P}(t) = \mathbf{X}_2(t)\mathbf{X}_1^{-1}(t) \quad (5.16)$$

Where:

$$\begin{cases} \begin{bmatrix} \mathbf{X}_1(t) \\ \mathbf{X}_2(t) \end{bmatrix} = e^{\mathbf{H}(t-t_f)} \begin{bmatrix} \mathbf{I} \\ \mathbf{C}^T\mathbf{S}\mathbf{C} \end{bmatrix} \\ \mathbf{H} = \begin{bmatrix} \mathbf{A} & -\mathbf{B}\mathbf{R}^{-1}\mathbf{B}^T \\ -\mathbf{C}^T\mathbf{Q}\mathbf{C} & -\mathbf{A}^T \end{bmatrix} \end{cases} \quad (5.17)$$

It is worth noticing that the optimal linear quadratic LQ tracker is not a causal system since it is needed to solve a system of differential equations backward in time.

5.2.2 Infinite horizon Linear Quadratic Tracker

The control design problem is to find a linear optimal tracking controller which minimizes the following performance index where error $\underline{e}(t)$ is defined in (5.3):

$$J(u(t)) = \frac{1}{2} \int_0^{\infty} \underline{e}^T(t) \mathbf{Q} \underline{e}(t) + u^T(t) \mathbf{R} u(t) dt \quad (5.18)$$

When (\mathbf{A}, \mathbf{B}) is detectable and $(\mathbf{A}, \sqrt{\mathbf{Q}})$ is detectable there exists a unique steady state solution of equations (5.15) obtained by means of the associated algebraic Riccati equation. Assuming that we want to achieve a perfect tracking of $\underline{r}(t)$ at its constant steady state value r_{ss} the control law (5.11) can be written as:

$$u(t) = -\mathbf{K}_x \underline{x}(t) + \mathbf{K}_f \underline{r}(t) \quad (5.19)$$

Where \mathbf{K}_x and \mathbf{K}_f are the state feedback and the feedforward gain respectively:

$$\begin{cases} \mathbf{K}_x = \mathbf{R}^{-1} \mathbf{B}^T \mathbf{P} \\ \mathbf{K}_f = \mathbf{R}^{-1} \mathbf{B}^T (\mathbf{PBR}^{-1} \mathbf{B}^T - \mathbf{A}^T)^{-1} (\mathbf{C}^T \mathbf{QM} - \mathbf{PG}) \end{cases} \quad (5.20)$$

Matrix \mathbf{P} is the positive definite solution of the following algebraic Riccati equation which is derived from the first equation of (5.15):

$$0 = \mathbf{A}^T \mathbf{P} + \mathbf{PA} - \mathbf{PBR}^{-1} \mathbf{B}^T \mathbf{P} + \mathbf{C}^T \mathbf{QC} \quad (5.21)$$

Similarly the feedforward gain \mathbf{K}_f is derived from the constant steady state value g_{ss} of $g(t)$. Indeed we get from the second equation of (5.15):

$$\begin{aligned} \underline{0} &= (\mathbf{A}^T - \mathbf{PBR}^{-1} \mathbf{B}^T) g_{ss} + (\mathbf{C}^T \mathbf{QM} - \mathbf{PG}) r_{ss} \\ \Rightarrow g_{ss} &= (\mathbf{PBR}^{-1} \mathbf{B}^T - \mathbf{A}^T)^{-1} (\mathbf{C}^T \mathbf{QM} - \mathbf{PG}) r_{ss} \end{aligned} \quad (5.22)$$

The closed loop system is then defined as follows:

$$\begin{cases} \dot{\underline{x}}(t) = \mathbf{A} \underline{x}(t) + \mathbf{B} u(t) + \mathbf{G} \underline{r}(t) \\ u(t) = -\mathbf{K}_x \underline{x}(t) + \mathbf{K}_f \underline{r}(t) \end{cases} \Rightarrow \dot{\underline{x}}(t) = (\mathbf{A} - \mathbf{BK}_x) \underline{x}(t) + (\mathbf{G} + \mathbf{BK}_f) \underline{r}(t) \quad (5.23)$$

Matrices \mathbf{Q} and \mathbf{R} shall be chosen so that a good response is obtained without exceeding the bandwidth and position limitations of the actuators. It is worth noticing that the gain computed in (5.20) are optimal only in steady state. In particular the feedforward gain provides perfect tracking only when $\underline{r}(t) = r_{ss}$.

5.3 Control with feedforward gain

We will consider in this section the following linear system, where $\underline{x}(t)$ is the state vector, $u(t)$ the control and $\underline{y}(t)$ the controlled output (that is the output of interest):

$$\begin{cases} \dot{\underline{x}}(t) = \mathbf{A} \underline{x}(t) + \mathbf{B} u(t) \\ \underline{y}(t) = \mathbf{C} \underline{x}(t) \end{cases} \quad (5.24)$$

Control with feedforward gain allows set point regulation. We will assume that control $u(t)$ has the following expression where \mathbf{H} is the feedforward matrix gain and where $\underline{r}(t)$ is the commanded value for the output $\underline{y}(t)$:

$$u(t) = -\mathbf{K}\underline{x}(t) + \mathbf{H}\underline{r}(t) \quad (5.25)$$

The optimal control problem is then split into two separate problems which are solved individually to form the suboptimal control:

- First the commanded value $\underline{r}(t)$ is set to zero and the gain \mathbf{K} is computed to solve the Linear Quadratic Regulator (LQR) problem;
- Then the feedforward matrix gain \mathbf{H} is computed such that the steady state value of output $\underline{y}(t)$ is equal to the commanded value $\underline{r}(t) = \underline{y}_c$.

$$\underline{r}(t) = \underline{y}_c \quad (5.26)$$

Using the expression (5.25) of the control $u(t)$ within the state space realization (5.24) of the linear system leads to:

$$\begin{cases} \dot{\underline{x}}(t) = \mathbf{A}\underline{x}(t) + \mathbf{B}u(t) = (\mathbf{A} - \mathbf{B}\mathbf{K})\underline{x}(t) + \mathbf{B}\mathbf{H}\underline{y}_c \\ \underline{y}(t) = \mathbf{C}\underline{x}(t) \end{cases} \quad (5.27)$$

Then matrix \mathbf{H} is computed such that the steady state value of output $\underline{y}(t)$ is \underline{y}_c ; assuming that $\dot{\underline{x}} = 0$ which corresponds to the steady state the preceding equations become:

$$\begin{cases} 0 = (\mathbf{A} - \mathbf{B}\mathbf{K})\underline{x} + \mathbf{B}\mathbf{H}\underline{y}_c \Leftrightarrow \underline{x} = -(\mathbf{A} - \mathbf{B}\mathbf{K})^{-1}\mathbf{B}\mathbf{H}\underline{y}_c \\ \underline{y} = \mathbf{C}\underline{x} \end{cases} \quad (5.28)$$

That is:

$$\underline{y} = -\mathbf{C}(\mathbf{A} - \mathbf{B}\mathbf{K})^{-1}\mathbf{B}\mathbf{H}\underline{y}_c \quad (5.29)$$

Setting \underline{y} to \underline{y}_c and assuming that the size of the output vector $\underline{y}(t)$ is the same than the size of the control vector u (square plant) leads to the following expression of the feedforward gain \mathbf{H} :

$$\underline{y} = \underline{y}_c \Rightarrow \mathbf{H} = -\left(\mathbf{C}(\mathbf{A} - \mathbf{B}\mathbf{K})^{-1}\mathbf{B}\right)^{-1} \quad (5.30)$$

For a square plant the feedforward gain \mathbf{H} is nothing than the inverse of the closed loop static gain. This gain is obtained by setting $s = 0$ in the expression of the closed loop transfer matrix.

5.4 Plant augmented with integrator

5.4.1 Integral augmentation

An alternative to make the steady state error exactly equal to zero in response to a step for the commanded value $\underline{r}(t) = \underline{y}_c$ is to replace the feedforward matrix gain \mathbf{H} by an integrator which will cancel the steady state error whatever the

input step (the system's type is augmented to be of type 1). The advantage of adding an integrator is that it eliminates the need to determine the feedforward matrix gain \mathbf{H} which could be difficult because of the uncertainty in the model. By augmenting the system with the integral error the LQR routine will choose the value of the integral gain automatically. The integrator is denoted \mathbf{T}/s , where $\mathbf{T} \neq \mathbf{0}$ is a constant which may be used to increase the response of the closed loop system. Adding an integrator augments the system's dynamics as follows:

$$\begin{cases} \dot{\underline{x}}(t) = \mathbf{A}\underline{x}(t) + \mathbf{B}\underline{u}(t) \\ \underline{y}(t) = \mathbf{C}\underline{x}(t) \\ \dot{\underline{x}}_i(t) = \underline{e}(t) = \mathbf{T}(r(t) - \underline{y}(t)) = \mathbf{T}\underline{r}(t) - \mathbf{T}\mathbf{C}\underline{x}(t) \end{cases} \quad (5.31)$$

$$\Leftrightarrow \begin{cases} \frac{d}{dt} \begin{bmatrix} \underline{x}(t) \\ \underline{x}_i(t) \end{bmatrix} = \begin{bmatrix} \mathbf{A} & \mathbf{0} \\ -\mathbf{T}\mathbf{C} & \mathbf{0} \end{bmatrix} \begin{bmatrix} \underline{x}(t) \\ \underline{x}_i(t) \end{bmatrix} + \begin{bmatrix} \mathbf{B} \\ \mathbf{0} \end{bmatrix} \underline{u}(t) + \begin{bmatrix} \mathbf{0} \\ \mathbf{T} \end{bmatrix} \underline{r}(t) \\ \underline{y}(t) = [\mathbf{C} \quad 0] \begin{bmatrix} \underline{x}(t) \\ \underline{x}_i(t) \end{bmatrix} \end{cases}$$

The suboptimal control is found by solving the LQR regulation problem where $\underline{r} = \underline{0}$:

- The augmented state space model reads:

$$\frac{d}{dt} \begin{bmatrix} \underline{x}(t) \\ \underline{x}_i(t) \end{bmatrix} = \dot{\underline{x}}_a(t) = \mathbf{A}_a \underline{x}_a(t) + \mathbf{B}_a \underline{u}(t)$$

$$\text{where } \begin{cases} \mathbf{A}_a = \begin{bmatrix} \mathbf{A} & \mathbf{0} \\ -\mathbf{T}\mathbf{C} & \mathbf{0} \end{bmatrix} \\ \mathbf{B}_a = \begin{bmatrix} \mathbf{B} \\ \mathbf{0} \end{bmatrix} \end{cases} \quad (5.32)$$

- The performance index $J(\underline{u}(t))$ to be minimized is the following:

$$J(\underline{u}(t)) = \frac{1}{2} \int_0^\infty \underline{x}_a^T(t) \mathbf{Q}_a \underline{x}_a(t) + \underline{u}^T(t) \mathbf{R} \underline{u}(t) dt \quad (5.33)$$

Where, denoting by \mathbf{N}_a a design matrix, matrix \mathbf{Q}_a is defined as follows:

$$\mathbf{Q}_a = \mathbf{N}_a^T \mathbf{N}_a \quad (5.34)$$

Note that design matrix \mathbf{N}_a shall be chosen such pair $(\mathbf{A}_a, \mathbf{N}_a)$ is detectable.

Assuming that pair $(\mathbf{A}_a, \mathbf{B}_a)$ is stabilizable and pair $(\mathbf{A}_a, \mathbf{N}_a)$ is detectable the algebraic Riccati equation can be solved. This leads to the following expression of the control $\underline{u}(t)$:

$$\begin{aligned} \underline{u}(t) &= -\mathbf{K}_a \underline{x}_a(t) + \underline{r}(t) \\ &= -\mathbf{R}^{-1} \mathbf{B}_a^T \mathbf{P} \underline{x}_a(t) + \underline{r}(t) \\ &= -\mathbf{R}^{-1} [\mathbf{B}^T \quad 0] \begin{bmatrix} \mathbf{P}_{11} & \mathbf{P}_{12} \\ \mathbf{P}_{21} & \mathbf{P}_{22} \end{bmatrix} \begin{bmatrix} \underline{x}(t) \\ \underline{x}_i(t) \end{bmatrix} + \underline{r}(t) \\ &= -\mathbf{R}^{-1} \mathbf{B}^T \mathbf{P}_{11} \underline{x}(t) - \mathbf{R}^{-1} \mathbf{B}^T \mathbf{P}_{12} \underline{x}_i(t) + \underline{r}(t) \\ &= -\mathbf{K}_p \underline{x}(t) - \mathbf{K}_i \underline{x}_i(t) + \underline{r}(t) \end{aligned} \quad (5.35)$$

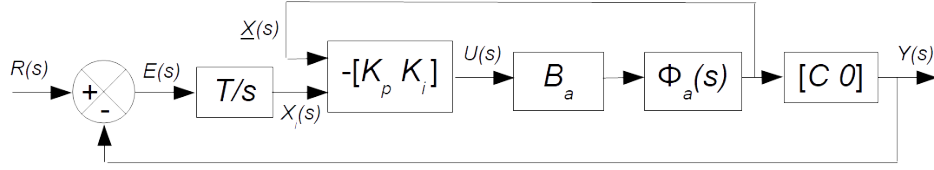

Figure 5.1: Plant augmented with integrator

Obviously, the term $\mathbf{K}_p = \mathbf{R}^{-1}\mathbf{B}^T\mathbf{P}_{11}$ represents the *proportional* gain of the control whereas the term $\mathbf{K}_i = \mathbf{R}^{-1}\mathbf{B}^T\mathbf{P}_{12}$ represents the *integral* gain of the control.

The state space equation of closed loop system is obtained by setting $\underline{u} = -\mathbf{K}_a\underline{x}_a + \underline{r} = -\mathbf{K}_p\underline{x} - \mathbf{K}_i\underline{x}_i + \underline{r}$ in (5.31):

$$\begin{cases} \frac{d}{dt} \begin{bmatrix} \underline{x} \\ \underline{x}_i \end{bmatrix} = (\mathbf{A}_a - \mathbf{B}_a\mathbf{K}) \underline{x}_a + \mathbf{B}_a\underline{r}(t) + \begin{bmatrix} \mathbf{0} \\ \mathbf{T} \end{bmatrix} \underline{r}(t) \\ = \begin{bmatrix} \mathbf{A} - \mathbf{B}\mathbf{K}_p & -\mathbf{B}\mathbf{K}_i \\ -\mathbf{T}\mathbf{C} & 0 \end{bmatrix} \begin{bmatrix} \underline{x} \\ \underline{x}_i \end{bmatrix} + \begin{bmatrix} \mathbf{B} \\ \mathbf{T} \end{bmatrix} \underline{r} \\ \underline{y} = [\mathbf{C} \ 0] \begin{bmatrix} \underline{x} \\ \underline{x}_i \end{bmatrix} \end{cases} \quad (5.36)$$

The corresponding bloc diagram is shown in Figure 5.1 where $\Phi_a(s) = (s\mathbb{I} - \mathbf{A}_a)^{-1}$.

5.4.2 Proof of the cancellation of the steady state error through integral augmentation

In order to proof that integrator cancels the steady state error when $\underline{r}(t)$ is a step input, let us compute the final value of the error $\underline{e}(t)$ using the final value theorem where s denotes the Laplace variable:

$$\lim_{t \rightarrow \infty} \underline{e}(t) = \lim_{s \rightarrow 0} s\underline{E}(s) \quad (5.37)$$

When $\underline{r}(t)$ is a step input with amplitude one, we have:

$$\underline{r}(t) = 1 \ \forall t \geq 0 \Rightarrow R(s) = \frac{1}{s} \quad (5.38)$$

Using the feedback $\underline{u} = -\mathbf{K}_a\underline{x}_a + \underline{r}$ the dynamics of the closed loop system is:

$$\begin{aligned} \dot{\underline{x}}_a &= (\mathbf{A}_a - \mathbf{B}_a\mathbf{K}_a) \underline{x}_a + \begin{bmatrix} \mathbf{B} \\ \mathbf{T} \end{bmatrix} \underline{r}(t) \\ \Rightarrow \underline{e}(t) &= \mathbf{T} (\underline{r}(t) - \underline{y}(t)) \\ &= \mathbf{T} \left(\underline{r}(t) - [\mathbf{C} \ 0] \begin{bmatrix} \underline{x} \\ \underline{x}_i \end{bmatrix} \right) \\ &= \mathbf{T} (\underline{r}(t) - [\mathbf{C} \ 0] \underline{x}_a) \end{aligned} \quad (5.39)$$

Using the Laplace transform, and denoting by \mathbb{I} the identity matrix, we get:

$$\begin{cases} \underline{X}_a(s) = (s\mathbb{I} - \mathbf{A}_a + \mathbf{B}_a\mathbf{K}_a)^{-1} \begin{bmatrix} \mathbf{B} \\ \mathbf{T} \end{bmatrix} \underline{R}(s) \\ \underline{E}(s) = \mathbf{T} (\underline{R}(s) - [\mathbf{C} \ 0] \underline{X}_a(s)) \end{cases} \quad (5.40)$$

Inserting (5.38) in (5.40) we get:

$$\underline{E}(s) = \mathbf{T} \left(1 - [\mathbf{C} \ \mathbf{0}] (s\mathbb{I} - \mathbf{A}_a + \mathbf{B}_a \mathbf{K}_a)^{-1} \begin{bmatrix} \mathbf{B} \\ \mathbf{T} \end{bmatrix} \right) \frac{1}{s} \quad (5.41)$$

Then the final value theorem (5.37) takes the following expression:

$$\begin{aligned} \lim_{t \rightarrow \infty} \underline{e}(t) &= \lim_{s \rightarrow 0} s \underline{E}(s) \\ &= \lim_{s \rightarrow 0} \mathbf{T} \left(\mathbb{I} - [\mathbf{C} \ \mathbf{0}] (s\mathbb{I} - \mathbf{A}_a + \mathbf{B}_a \mathbf{K}_a)^{-1} \begin{bmatrix} \mathbf{B} \\ \mathbf{T} \end{bmatrix} \right) \\ &= \mathbf{T} \left(1 - [\mathbf{C} \ \mathbf{0}] (-\mathbf{A}_a + \mathbf{B}_a \mathbf{K}_a)^{-1} \begin{bmatrix} \mathbf{B} \\ \mathbf{T} \end{bmatrix} \right) \end{aligned} \quad (5.42)$$

Let us focus on the inverse of the matrix $-\mathbf{A}_a + \mathbf{B}_a \mathbf{K}_a$. First we write \mathbf{K}_a as $\mathbf{K}_a = [\mathbf{K}_p \ \mathbf{K}_i]$, where \mathbf{K}_p and \mathbf{K}_i represents respectively the proportional and the integral gains. Then using (5.32) we get:

$$-\mathbf{A}_a + \mathbf{B}_a \mathbf{K}_a = \begin{bmatrix} -\mathbf{A} & \mathbf{0} \\ \mathbf{TC} & \mathbf{0} \end{bmatrix} + \begin{bmatrix} \mathbf{B} \\ \mathbf{0} \end{bmatrix} [\mathbf{K}_p \ \mathbf{K}_i] = \begin{bmatrix} -\mathbf{A} + \mathbf{BK}_p & \mathbf{BK}_i \\ \mathbf{TC} & \mathbf{0} \end{bmatrix} \quad (5.43)$$

Assuming that \mathbf{X} , \mathbf{Y} and \mathbf{Z} are square invertible matrices, it can be shown that the inverse of the matrix $\begin{bmatrix} \mathbf{X} & \mathbf{Y} \\ \mathbf{Z} & \mathbf{0} \end{bmatrix}$ is the following:

$$\begin{bmatrix} \mathbf{X} & \mathbf{Y} \\ \mathbf{Z} & \mathbf{0} \end{bmatrix}^{-1} = \begin{bmatrix} \mathbf{0} & \mathbf{Z}^{-1} \\ \mathbf{Y}^{-1} & -\mathbf{Y}^{-1} \mathbf{X} \mathbf{Z}^{-1} \end{bmatrix} \quad (5.44)$$

Thus:

$$\begin{aligned} (-\mathbf{A}_a + \mathbf{B}_a \mathbf{K}_a)^{-1} &= \begin{bmatrix} -\mathbf{A} + \mathbf{BK}_p & \mathbf{BK}_i \\ \mathbf{TC} & \mathbf{0} \end{bmatrix}^{-1} \\ &= \begin{bmatrix} \mathbf{0} & (\mathbf{TC})^{-1} \\ (\mathbf{BK}_i)^{-1} & -(\mathbf{BK}_i)^{-1} (-\mathbf{A} + \mathbf{BK}_p) (\mathbf{TC})^{-1} \end{bmatrix} \end{aligned} \quad (5.45)$$

And:

$$\begin{aligned} (-\mathbf{A}_a + \mathbf{B}_a \mathbf{K})^{-1} \begin{bmatrix} \mathbf{B} \\ \mathbf{T} \end{bmatrix} &= \begin{bmatrix} \mathbf{0} & (\mathbf{TC})^{-1} \\ (\mathbf{BK}_i)^{-1} & -(\mathbf{BK}_i)^{-1} (-\mathbf{A} + \mathbf{BK}_p) (\mathbf{TC})^{-1} \end{bmatrix} \begin{bmatrix} \mathbf{B} \\ \mathbf{T} \end{bmatrix} \\ &= \begin{bmatrix} (\mathbf{TC})^{-1} \mathbf{T} \\ (\mathbf{BK}_i)^{-1} (\mathbf{B} + (\mathbf{A} - \mathbf{BK}_p) (\mathbf{TC})^{-1} \mathbf{T}) \end{bmatrix} \\ \Rightarrow [\mathbf{C} \ \mathbf{0}] (-\mathbf{A}_a + \mathbf{B}_a \mathbf{K})^{-1} \begin{bmatrix} \mathbf{B} \\ \mathbf{T} \end{bmatrix} &= [\mathbf{C} \ \mathbf{0}] \begin{bmatrix} (\mathbf{TC})^{-1} \mathbf{T} \\ (\mathbf{BK}_i)^{-1} (\mathbf{B} + (\mathbf{A} - \mathbf{BK}_p) (\mathbf{TC})^{-1} \mathbf{T}) \end{bmatrix} \\ &= \mathbf{C} (\mathbf{TC})^{-1} \mathbf{T} \\ &= 1 \end{aligned} \quad (5.46)$$

Consequently, using (5.46) in (5.42), the final value of the error $\underline{e}(t)$ becomes:

$$\lim_{t \rightarrow \infty} \underline{e}(t) = \mathbf{T} \left(1 - [\mathbf{C} \ \mathbf{0}] (-\mathbf{A}_a + \mathbf{B}_a \mathbf{K}_a)^{-1} \begin{bmatrix} \mathbf{B} \\ \mathbf{T} \end{bmatrix} \right) = \mathbf{T} (1 - 1) = 0 \quad (5.47)$$

As a consequence, the integrator allows to cancel the steady state error whatever the input step. It is worth noticing that the result does not hold as far as the output $\underline{y}(t)$ takes the form $\underline{y} = \mathbf{C}\underline{x} + \mathbf{D}\underline{u}$ rather than $\underline{y} = \mathbf{C}\underline{x}$.

5.5 Dynamic compensator

In the same spirit than what has been developed previously, we replace the integrator by a dynamic compensator of prescribed structure into the system. The dynamics of the compensator has the form:

$$\begin{cases} \dot{w} = \mathbf{F}w + \mathbf{G}e \\ v = \mathbf{D}w + \mathbf{E}e \end{cases} \quad (5.48)$$

With state w , output v and input e equal to the tracking error:

$$e = \mathbf{T}(r - \underline{y}) \quad (5.49)$$

Matrices $\mathbf{F}, \mathbf{G}, \mathbf{D}, \mathbf{E}$ and \mathbf{T} are known and chosen to include the desired structure in the compensator. Combining (5.1), (5.48) and (5.49) we get the following expression for the dynamics and output written in augmented form:

$$\begin{cases} \dot{\underline{x}} = \mathbf{A}\underline{x} + \mathbf{B}u \\ \underline{y} = \mathbf{C}\underline{x} \\ \dot{w} = \mathbf{F}w + \mathbf{G}e \\ v = \mathbf{D}w + \mathbf{E}e \\ e = \mathbf{T}(r - \underline{y}) = \mathbf{T}r - \mathbf{T}\mathbf{C}\underline{x} \end{cases} \quad (5.50)$$

$$\Rightarrow \begin{cases} \frac{d}{dt} \begin{bmatrix} \underline{x} \\ w \end{bmatrix} = \begin{bmatrix} \mathbf{A} & 0 \\ -\mathbf{G}\mathbf{T}\mathbf{C} & \mathbf{F} \end{bmatrix} \begin{bmatrix} \underline{x} \\ w \end{bmatrix} + \begin{bmatrix} \mathbf{B} \\ 0 \end{bmatrix} u + \begin{bmatrix} 0 \\ \mathbf{G}\mathbf{T} \end{bmatrix} r \\ \begin{bmatrix} \underline{y} \\ v \end{bmatrix} = \begin{bmatrix} \mathbf{C} & 0 \\ -\mathbf{E}\mathbf{T}\mathbf{C} & \mathbf{D} \end{bmatrix} \begin{bmatrix} \underline{x} \\ w \end{bmatrix} + \begin{bmatrix} 0 \\ \mathbf{E}\mathbf{T} \end{bmatrix} r \end{cases}$$

By redefining the state, the output and the matrix variables to streamline the notation, we see that the augmented equations (5.50) are of the form:

$$\begin{cases} \dot{\underline{x}}_a = \mathbf{A}_a\underline{x}_a + \mathbf{B}_a u + \mathbf{G}_a r \\ \underline{y}_a = \mathbf{C}_a\underline{x}_a + \mathbf{F}_a r \end{cases} \quad (5.51)$$

- If the dynamic compensator is able to give satisfactory response without the knowledge of reference r (through integral augmentation for example) then we may solve the LQ regulator problem for the following augmented system where reference r no more appears:

$$\frac{d}{dt} \begin{bmatrix} \underline{x} \\ w \end{bmatrix} = \begin{bmatrix} \mathbf{A} & 0 \\ -\mathbf{G}\mathbf{T}\mathbf{C} & \mathbf{F} \end{bmatrix} \begin{bmatrix} \underline{x} \\ w \end{bmatrix} + \begin{bmatrix} \mathbf{B} \\ 0 \end{bmatrix} u = \mathbf{A}_a\underline{x}_a + \mathbf{B}_a u \quad (5.52)$$

- On the other hand we may use set point regulation. This option is developed hereafter.

We will denote \underline{x}_{ae} and u_e the steady state and control of augmented state $\underline{x}_a(t)$ and control $u(t)$, and by tilde the deviation from the steady state. By definition of steady state and control we have:

$$\begin{cases} \mathbf{A}_a \underline{x}_{ae} + \mathbf{B}_a u_e + \mathbf{G}_a r = 0 \\ \mathbf{C}_a \underline{x}_{ae} + \mathbf{F}_a r = 0 \end{cases} \Leftrightarrow \begin{bmatrix} \mathbf{A}_a & \mathbf{B}_a \\ \mathbf{C}_a & 0 \end{bmatrix} \begin{bmatrix} \underline{x}_{ae} \\ u_e \end{bmatrix} = \begin{bmatrix} -\mathbf{G}_a \\ -\mathbf{F}_a \end{bmatrix} r \quad (5.53)$$

We finally get:

$$\begin{cases} \dot{\tilde{\underline{x}}}_a &= \dot{\underline{x}}_a - 0 \\ &= \mathbf{A}_a \underline{x}_a + \mathbf{B}_a u + \mathbf{G}_a r - (\mathbf{A}_a \underline{x}_{ae} + \mathbf{B}_a u_e + \mathbf{G}_a r) \\ &= \mathbf{A}_a \tilde{\underline{x}}_a + \mathbf{B}_a \tilde{u} \\ \underline{y}_a &= \mathbf{C}_a \underline{x}_a + \mathbf{F}_a r - (\mathbf{C}_a \underline{x}_{ae} + \mathbf{F}_a r) \\ &= \mathbf{C}_a \tilde{\underline{x}}_a \end{cases} \quad (5.54)$$

Then the expression of the control $\tilde{u}(t)$ is:

$$\tilde{u}(t) = -\mathbf{K} \tilde{\underline{x}}_a(t) = -\mathbf{R}^{-1} \mathbf{B}^T \mathbf{P} \tilde{\underline{x}}_a(t) \quad (5.55)$$

Where \mathbf{P} is the solution of the following algebraic Riccati equation:

$$\mathbf{P} \mathbf{A}_a + \mathbf{A}_a^T \mathbf{P} - \mathbf{P} \mathbf{B}_a \mathbf{R}^{-1} \mathbf{B}_a^T \mathbf{P} + \mathbf{C}_a^T \mathbf{Q} \mathbf{C}_a = 0 \quad (5.56)$$

The control $\tilde{u}(t)$ minimizes the following performance index:

$$J(\tilde{u}(t)) = \frac{1}{2} \int_0^\infty \tilde{\underline{x}}_a^T(t) \mathbf{C}_a^T \mathbf{Q} \mathbf{C}_a \tilde{\underline{x}}_a(t) + \tilde{u}^T(t) \mathbf{R} \tilde{u}(t) dt \quad (5.57)$$

Chapter 6

Linear Quadratic Gaussian (LQG) regulator

6.1 Introduction

The design of the Linear Quadratic Regulator (LQR) assumes that the whole state is available for control and that there is no noise. Those assumptions may appear unrealistic in practical applications. We will assume in that chapter that the process to be controlled is described by the following linear time invariant model where $w(t)$ and $v(t)$ are random vectors which represents the process noise and the measurement noise respectively:

$$\begin{cases} \frac{d}{dt}x(t) = \mathbf{A}x(t) + \mathbf{B}u(t) + w(t) \\ y(t) = \mathbf{C}x(t) + v(t) \end{cases} \quad (6.1)$$

The preceding relationship can be equivalently represented by the block diagram on Figure 6.1.

The Linear Quadratic Gaussian (LQG) regulator deals with the design of a regulator which minimises a quadratic cost using the available output and taking into account the noise into the process and the available output for control. As far as only the output $y(t)$ is now available for control (not the full state $x(t)$), the separation principle will be used to design the LQG regulator:

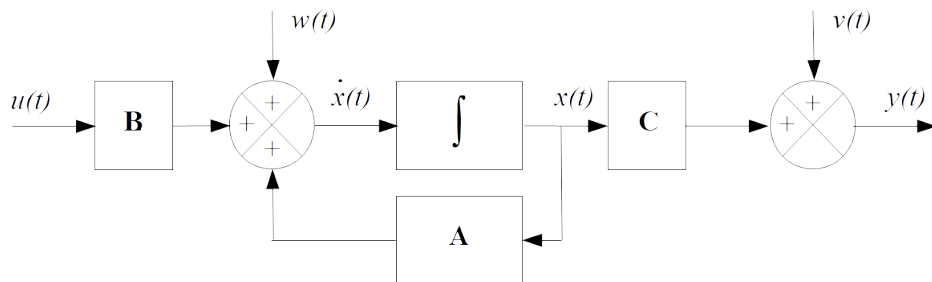

Figure 6.1: Open-loop linear system with process and measurement noises

- First an estimator will be used to estimate the the full state using the available output $y(t)$
- Then an LQ controller will be designed using the the state estimation in place of the true (but unknown) state $x(t)$

6.2 Luenberger observer

Consider a process with the following state space model where $y(t)$ denotes the measured output and $u(t)$ the control input:

$$\begin{cases} \frac{d}{dt}x(t) = \mathbf{A}x(t) + \mathbf{B}u(t) \\ y(t) = \mathbf{C}x(t) \end{cases} \quad (6.2)$$

We assume that $x(t)$ cannot be measured and the goal of the observer is to estimate $x(t)$ based on $y(t)$. Luenberger observer (1964) provides an estimation of the state vector through the following differential equation where matrices \mathbf{F} , \mathbf{J} and \mathbf{L} have to be determined:

$$\frac{d}{dt}\hat{x}(t) = \mathbf{F}\hat{x}(t) + \mathbf{J}u(t) + \mathbf{L}y(t) \quad (6.3)$$

The estimation error $e(t)$ is defined as follows:

$$e(t) = x(t) - \hat{x}(t) \quad (6.4)$$

Thus using (6.2) and (6.3) its time derivative reads:

$$\dot{e}(t) = \dot{x}(t) - \dot{\hat{x}}(t) = \mathbf{A}x(t) + \mathbf{B}u(t) - (\mathbf{F}\hat{x}(t) + \mathbf{J}u(t) + \mathbf{L}y(t)) \quad (6.5)$$

Using (6.4) and the output equation $y(t) = \mathbf{C}x(t)$ the preceding relationship can be rewritten as follows:

$$\begin{aligned} \dot{e}(t) &= \mathbf{A}x(t) + \mathbf{B}u(t) - \mathbf{F}(x(t) - e(t)) - \mathbf{J}u(t) - \mathbf{L}\mathbf{C}x(t) \\ &= \mathbf{F}e(t) + (\mathbf{A} - \mathbf{F} - \mathbf{L}\mathbf{C})x(t) + (\mathbf{B} - \mathbf{J})u(t) \end{aligned} \quad (6.6)$$

As soon as the purpose of the observer is to move the estimation error $e(t)$ towards zero independently of control $u(t)$ and *true* state vector $x(t)$ we choose matrices \mathbf{F} and \mathbf{J} as follows:

$$\begin{cases} \mathbf{J} = \mathbf{B} \\ \mathbf{F} = \mathbf{A} - \mathbf{L}\mathbf{C} \end{cases} \quad (6.7)$$

Thus the dynamics of the estimation error $e(t)$ reduces to be:

$$\dot{e}(t) = \mathbf{F}e(t) = (\mathbf{A} - \mathbf{L}\mathbf{C})e(t) \quad (6.8)$$

Where matrix \mathbf{L} shall be chosen such that all the eigenvalues of $\mathbf{A} - \mathbf{L}\mathbf{C}$ are situated in the left half plane. Furthermore the Luenberger observer (6.3) can now be written as follows using (6.7):

$$\begin{aligned} \frac{d}{dt}\hat{x}(t) &= (\mathbf{A} - \mathbf{L}\mathbf{C})\hat{x}(t) + \mathbf{B}u(t) + \mathbf{L}y(t) \\ &= \mathbf{A}\hat{x}(t) + \mathbf{B}u(t) + \mathbf{L}(y(t) - \mathbf{C}\hat{x}(t)) \end{aligned} \quad (6.9)$$

Figure 6.2 shows the structure of the Luenberger observer.

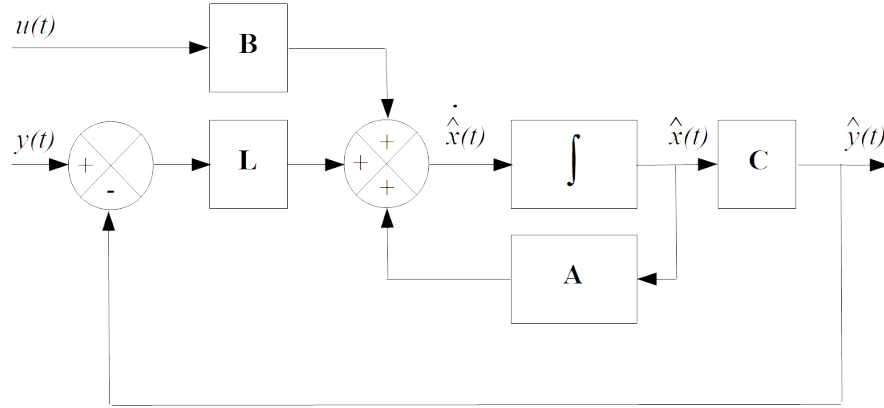

Figure 6.2: Luenberger observer

6.3 White noise through Linear Time Invariant (LTI) system

6.3.1 Assumptions and definitions

Let's consider the following linear time invariant system which is fed by a random vector $w(t)$ of dimension n (which is also the dimension of the state vector $x(t)$):

$$\begin{cases} \frac{d}{dt}x(t) = \mathbf{A}x(t) + \mathbf{B}w(t) \\ y(t) = \mathbf{C}x(t) \end{cases} \quad (6.10)$$

We will assume that $w(t)$ is a white noise (i.e. uncorrelated) with zero mean Gaussian probability density function (pdf). The covariance matrix of the Gaussian probability density function $p(w)$ will be denoted \mathbf{P}_w , whereas its mean will be denoted $E[w(t)]$ and its autocorrelation function $\mathbf{R}_w(\tau)$ will be denoted $E[w(t)w^T(t+\tau)]$ where E designates the expectation operator and δ the Dirac delta function:

$$\begin{cases} p(w) = \frac{1}{(2\pi)^{n/2} \sqrt{\det(\mathbf{P}_w)}} e^{-\frac{1}{2}w^T \mathbf{P}_w^{-1} w} \\ E[w(t)] = m_w(t) = 0 \\ \mathbf{R}_w(\tau) = E[w(t)w^T(t+\tau)] = \mathbf{P}_w \delta(\tau) \text{ where } \mathbf{P}_w = \mathbf{P}_w^T > 0 \end{cases} \quad (6.11)$$

We said that $w(t)$ is a wide-sense stationary (WSS) random process because the two following properties hold:

- The mean $m_w(t) = E[w(t)]$ of $w(t)$ is constant;
- The autocorrelation function $\mathbf{R}_w(t, t+\tau) = E[(w(t) - m_w(t))(w(t+\tau) - m_w(t+\tau))^T]$ just depends on the time difference $\tau = (t+\tau) - t$.

6.3.2 Mean and covariance matrix of the state vector

As far as $w(t)$ is a random vector it is clear from (6.10) that the state vector $x(t)$ and the output vector $y(t)$ are also a random vectors. Let $m_x(0)$ be the

mean of the state vector $x(t)$ at $t = 0$ and $\mathbf{P}_x(0)$ be the covariance matrix of the state vector $x(t)$ at $t = 0$. Then it can be shown that $x(t)$ is a Gaussian random vector:

- with mean $m_x(t)$ given by:

$$m_x(t) = E[x(t)] = e^{\mathbf{A}t} m_x(0) \quad (6.12)$$

- with covariance matrix $\mathbf{P}_x(t)$ which is defined as follows:

$$\mathbf{P}_x(t) = E[(x(t) - m_x(t))(x(t) - m_x(t))^T] \quad (6.13)$$

Matrix $\mathbf{P}_x(t)$ is the solution of the following differential Lyapunov equation:

$$\dot{\mathbf{P}}_x(t) = \mathbf{A}\mathbf{P}_x(t) + \mathbf{P}_x(t)\mathbf{A}^T + \mathbf{B}\mathbf{P}_w\mathbf{B}^T \quad (6.14)$$

Assuming that the system is *stable* (i.e. all the eigenvalues of the state matrix \mathbf{A} have negative real part) the random process $x(t)$ will become stationary after a certain amount of time: its mean $m_x(t)$ will be zero whereas the value of its covariance matrix $\mathbf{P}_x(t)$ will turn to be the solution \mathbf{P}_x of the following algebraic Lyapunov equation:

$$\mathbf{A}\mathbf{P}_x + \mathbf{P}_x\mathbf{A}^T + \mathbf{B}\mathbf{P}_w\mathbf{B}^T = 0 \quad (6.15)$$

Thus after a certain amount of time the state vector $x(t)$ as well as the output vector $y(t)$ are wide-sense stationary (WSS) random processes.

6.3.3 Autocorrelation function of the stationary output vector

The autocorrelation function $R_y(\tau)$ (which may be a matrix for vector signal) of the output vector $y(t)$ is defined as follows:

$$\begin{aligned} R_y(\tau) &= E[(y(t) - \mathbf{C}m_x(t))(y(t + \tau) - \mathbf{C}m_x(t + \tau))^T] \\ &= \mathbf{C}R_x(\tau)\mathbf{C}^T \end{aligned} \quad (6.16)$$

Where $R_x(\tau)$ is the autocorrelation function of the stationary state vector $x(t)$:

$$R_x(\tau) = E[(x(t) - m_x(t))(x(t + \tau) - m_x(t + \tau))^T] \quad (6.17)$$

It is clear from the definition of the autocorrelation function $R_y(\tau)$ that the stationary value of the covariance matrix \mathbf{P}_y of $y(t)$ is equal to the value of the autocorrelation function $R_y(\tau)$ at $\tau = 0$:

$$\begin{aligned} \mathbf{P}_y &= E[(y(t) - \mathbf{C}m_x(t))(y(t) - \mathbf{C}m_x(t))^T] \\ &= \mathbf{C}\mathbf{P}_x\mathbf{C}^T \\ &= R_y(\tau)|_{\tau=0} \end{aligned} \quad (6.18)$$

The power spectral density (psd) $S_y(f)$ of a stationary process $y(t)$ is given by the Fourier transform of its autocorrelation function $R_y(\tau)$:

$$S_y(f) = \int_{-\infty}^{+\infty} R_y(\tau) e^{-j2\pi f\tau} d\tau \quad (6.19)$$

Let $S_y(s)$ be the (one-sided) Laplace transform of the autocorrelation function $R_y(\tau)$:

$$S_y(s) = \mathcal{L}[R_y(\tau)] = \int_0^{+\infty} R_y(\tau)e^{-s\tau}d\tau \quad (6.20)$$

It can be seen that the power spectral density (psd) $S_y(f)$ of $y(t)$ can be obtained thanks to the Laplace transform $S_y(s)$ of $R_y(\tau)$ as:

$$S_y(f) = S_y(-s)|_{s=j2\pi f} + S_y(s)|_{s=j2\pi f} \quad (6.21)$$

Indeed we can write:

$$\begin{aligned} S_y(f) &= \int_{-\infty}^{+\infty} R_y(\tau)e^{-j2\pi f\tau}d\tau \\ &= \int_{-\infty}^0 R_y(\tau)e^{-j2\pi f\tau}d\tau + \int_0^{+\infty} R_y(\tau)e^{-j2\pi f\tau}d\tau \\ &= \int_{-\infty}^0 R_y(\tau)e^{-s\tau}d\tau \Big|_{s=j2\pi f} + \int_0^{+\infty} R_y(\tau)e^{-s\tau}d\tau \Big|_{s=j2\pi f} \\ &= \int_0^{+\infty} R_y(-\tau)e^{s\tau}d\tau \Big|_{s=j2\pi f} + \int_0^{+\infty} R_y(\tau)e^{-s\tau}d\tau \Big|_{s=j2\pi f} \end{aligned} \quad (6.22)$$

As far as $R_y(\tau)$ is an even function we get:

$$\begin{aligned} R_y(-\tau) &= R_y(\tau) \\ \Rightarrow S_y(f) &= \int_0^{+\infty} R_y(\tau)e^{s\tau}d\tau \Big|_{s=j2\pi f} + \int_0^{+\infty} R_y(\tau)e^{-s\tau}d\tau \Big|_{s=j2\pi f} \end{aligned} \quad (6.23)$$

The preceding equations reads:

$$S_y(f) = S_y(-s)|_{s=j2\pi f} + S_y(s)|_{s=j2\pi f} \quad (6.24)$$

Furthermore let $G(s)$ be the transfer function of the linear system, which is assumed to be stable:

$$G(s) = \mathbf{C}(s\mathbb{I} - \mathbf{A})^{-1}\mathbf{B} \quad (6.25)$$

Then it can be shown that:

$$\begin{aligned} S_y(-s) + S_y(s) &= G(-s)\mathbf{P}_w G^T(s) \\ \Rightarrow S_y(f) &= G(-s)\mathbf{P}_w G^T(s) \Big|_{s=j2\pi f} \end{aligned} \quad (6.26)$$

The preceding relationship indicates that the (one-sided) Laplace transform $S_y(s)$ can be obtained by identifying $G(-s)\mathbf{P}_w G^T(s)$ to the sum $S_y(-s) + S_y(s)$ where $S_y(s)$ is a *stable* transfer function. Furthermore using the initial value theorem on the (one-sided) Laplace transform $S_y(s)$ we get the following result:

$$\mathbf{P}_y = R_y(\tau)|_{\tau=0} = \lim_{s \rightarrow \infty} sS_y(s) \quad (6.27)$$

Example 6.1. Let $G(s)$ be a first order system with time constant a and let $\underline{w}(t)$ be a white noise with covariance \mathbf{P}_w :

$$\begin{cases} G(s) = \frac{1}{1+as} \\ R_w(\tau) = E[\underline{w}(t)\underline{w}^T(t+\tau)] = \mathbf{P}_w\delta(\tau) \text{ where } \mathbf{P}_w = \mathbf{P}_w^T > 0 \end{cases} \quad (6.28)$$

One realization of transfer function $G(s)$ is the following:

$$\begin{cases} \dot{x}(t) = -\frac{1}{a}x(t) + \underline{w}(t) \\ y(t) = \frac{1}{a}x(t) \end{cases} \quad (6.29)$$

That is:

$$\begin{cases} \dot{x}(t) = \mathbf{A}x(t) + \mathbf{B}w(t) \\ y(t) = \mathbf{C}x(t) \end{cases} \quad (6.30)$$

Where:

$$\begin{cases} \mathbf{A} = -\frac{1}{a} \\ \mathbf{B} = 1 \\ \mathbf{C} = \frac{1}{a} \end{cases} \Rightarrow G(s) = \mathbf{C}(s\mathbb{I} - \mathbf{A})^{-1}\mathbf{B} \quad (6.31)$$

As far as $a > 0$ the system is stable. The covariance matrix $\mathbf{P}_x(t)$ is defined as follows:

$$\mathbf{P}_x(t) = E \left[(x(t) - m_x(t)) (x(t) - m_x(t))^T \right] \quad (6.32)$$

Where matrix $\mathbf{P}_x(t)$ is the solution of the following differential Lyapunov equation:

$$\dot{\mathbf{P}}_x(t) = \mathbf{A}\mathbf{P}_x(t) + \mathbf{P}_x(t)\mathbf{A}^T + \mathbf{B}\mathbf{P}_w\mathbf{B}^T = -\frac{2}{a}\mathbf{P}_x(t) + \mathbf{P}_w \quad (6.33)$$

We get:

$$\mathbf{P}_x(t) = \frac{a}{2}\mathbf{P}_w + \left(\mathbf{P}_x(0) - \frac{a}{2}\mathbf{P}_w \right) e^{-\frac{2t}{a}} \quad (6.34)$$

The stationary value \mathbf{P}_x of the covariance matrix $\mathbf{P}_x(t)$ of the state vector $x(t)$ is obtained as $t \rightarrow \infty$:

$$\mathbf{P}_x = \lim_{t \rightarrow \infty} \mathbf{P}_x(t) = \frac{a}{2}\mathbf{P}_w \quad (6.35)$$

Consequently the stationary value \mathbf{P}_y of the covariance matrix of the output vector $y(t)$ reads:

$$\mathbf{P}_y = \mathbf{C}\mathbf{P}_x\mathbf{C}^T = \frac{1}{a^2} \times \frac{a}{2}\mathbf{P}_w = \frac{\mathbf{P}_w}{2a} \quad (6.36)$$

This result can be retrieved thanks to the power spectral density (psd) of the output vector $y(t)$. Indeed let's compute the power spectral density (psd) $S_y(f)$ of the output stationary process $y(t)$ of the system:

$$S_y(f) = \int_{-\infty}^{+\infty} R_y(\tau) e^{-j2\pi f\tau} d\tau = G(-s)\mathbf{P}_w G^T(s) \Big|_{s=j2\pi f} \quad (6.37)$$

We get:

$$\begin{aligned} G(-s)\mathbf{P}_w G^T(s) &= \frac{\mathbf{P}_w}{(1+as)(1-as)} = \frac{\mathbf{P}_w}{1-(as)^2} \\ \Rightarrow S_y(f) &= G(-s)\mathbf{P}_w G^T(s) \Big|_{s=j2\pi f} = \frac{\mathbf{P}_w}{1+(2\pi fa)^2} \end{aligned} \quad (6.38)$$

Furthermore let's decompose $\frac{\mathbf{P}_w}{1-(as)^2}$ as the sum $S_y(-s) + S_y(s)$:

$$\frac{\mathbf{P}_w}{1-(as)^2} = \frac{\mathbf{P}_w}{2} \frac{1}{1-as} + \frac{\mathbf{P}_w}{2} \frac{1}{1+as} = S_y(-s) + S_y(s) \quad (6.39)$$

Thus by identification we get for the stable transfer function $S_y(s)$:

$$S_y(s) = \frac{\mathbf{P}_w}{2} \frac{1}{1+as} \quad (6.40)$$

The autocorrelation function $R_y(\tau)$ is given by the inverse Laplace transform of $S_y(s)$:

$$R_y(\tau) = \mathcal{L}^{-1}[S_y(s)] = \mathcal{L}^{-1}\left[\frac{\mathbf{P}_w}{2a} \frac{1}{1/a + s}\right] = \frac{\mathbf{P}_w}{2a} e^{-\frac{\tau}{a}} \quad \forall \tau \geq 0 \quad (6.41)$$

As far as $R_y(\tau)$ is an even function we get:

$$R_y(\tau) = \frac{\mathbf{P}_w}{2a} e^{\frac{\tau}{a}} \quad \forall \tau \leq 0 \quad (6.42)$$

Thus the autocorrelation function $R_y(\tau)$ for $\tau \in \mathbb{R}$ reads:

$$R_y(\tau) = \frac{\mathbf{P}_w}{2a} e^{-\frac{|\tau|}{a}} \quad \forall \tau \in \mathbb{R} \quad (6.43)$$

Finally we use the initial value theorem on the (one-sided) Laplace transform $S_y(s)$ to get the following result:

$$\mathbf{P}_y = R_y(\tau)|_{\tau=0} = \lim_{s \rightarrow \infty} s S_y(s) = \frac{\mathbf{P}_w}{2a} \quad (6.44)$$

■

6.4 Kalman-Bucy filter

6.4.1 Linear Quadratic Estimator

Let's consider the following linear time invariant model where $w(t)$ and $v(t)$ are random vectors which represents the process noise and the measurement noise respectively:

$$\begin{cases} \frac{d}{dt}x(t) = \mathbf{A}x(t) + \mathbf{B}u(t) + w(t) \\ y(t) = \mathbf{C}x(t) + v(t) \end{cases} \quad (6.45)$$

The Kalman-Bucy filter is a state estimator that is optimal in the sense that it minimizes the covariance of the estimated error $e(t) = x(t) - \hat{x}(t)$ when the following conditions are met:

- Random vectors $w(t)$ and $v(t)$ are zero mean Gaussian noise. Let $p(w)$ and $p(v)$ be the probability density function of random vectors $w(t)$ and $v(t)$. Then:

$$\begin{cases} p(w) = \frac{1}{(2\pi)^{n/2} \sqrt{\det(\mathbf{P}_w)}} e^{-\frac{1}{2}w^T \mathbf{P}_w^{-1} w} \\ p(v) = \frac{1}{(2\pi)^{p/2} \sqrt{\det(\mathbf{Q}_v)}} e^{-\frac{1}{2}v^T \mathbf{Q}_v^{-1} v} \end{cases} \quad (6.46)$$

- Random vectors $w(t)$ and $v(t)$ are white noise (i.e. uncorrelated). The covariance matrices of $w(t)$ and $v(t)$ will be denoted \mathbf{P}_w and \mathbf{Q}_v respectively:

$$\begin{cases} E[w(t)w^T(t+\tau)] = \mathbf{P}_w \delta(\tau) \text{ where } \mathbf{P}_w > 0 \\ E[v(t)v^T(t+\tau)] = \mathbf{Q}_v \delta(\tau) \text{ where } \mathbf{Q}_v > 0 \end{cases} \quad (6.47)$$

- The cross correlation between $w(t)$ and $v(t)$ is zero:

$$E [w(t)v^T(t + \tau)] = 0 \quad (6.48)$$

The Kalman-Bucy filter is a special form of the Luenberger observer (6.9):

$$\frac{d}{dt}\hat{x}(t) = \mathbf{A}\hat{x}(t) + \mathbf{B}u(t) + \mathbf{L}(t)(y(t) - \mathbf{C}\hat{x}(t)) \quad (6.49)$$

Where the time dependent observer gain $\mathbf{L}(t)$, also called Kalman gain, is given by:

$$\mathbf{L}(t) = \Pi(t)\mathbf{C}^T\mathbf{Q}_v^{-1} \quad (6.50)$$

The symmetric positive definite matrix $\Pi(t) = \Pi^T(t) > 0$ is the solution of the following Riccati equation:

$$\dot{\Pi}(t) = \mathbf{A}\Pi(t) + \Pi(t)\mathbf{A}^T - \Pi(t)\mathbf{C}^T\mathbf{Q}_v^{-1}\mathbf{C}\Pi(t) + \mathbf{P}_w \quad (6.51)$$

The suboptimal observer gain $\mathbf{L} = \Pi\mathbf{C}^T\mathbf{Q}_v^{-1}$ is obtained thanks to the positive semi-definite steady state solution of the following algebraic Riccati equation:

$$\begin{cases} \mathbf{L} = \Pi\mathbf{C}^T\mathbf{Q}_v^{-1} \\ 0 = \mathbf{A}\Pi + \Pi\mathbf{A}^T - \Pi\mathbf{C}^T\mathbf{Q}_v^{-1}\mathbf{C}\Pi + \mathbf{P}_w \end{cases} \quad (6.52)$$

Kalman gain shall be tuned when the covariance matrices \mathbf{P}_w and \mathbf{Q}_v are not known:

- When measurements $y(t)$ are very noisy the coefficients of covariance matrix \mathbf{Q}_v are high and Kalman gain will be quite small;
- On the other hand when we do not trust very much the linear time invariant model of the process the coefficients of covariance matrix \mathbf{P}_w are high and Kalman gain will be quite high.

From a practical point of view matrices \mathbf{P}_w and \mathbf{Q}_v are design parameters which are tuned to achieve the desired properties of the closed-loop.

6.4.2 Sketch of the proof

To get this result let's consider the following estimation error $e(t)$:

$$e(t) = x(t) - \hat{x}(t) \quad (6.53)$$

Thus using (6.45) and (6.49) its time derivative reads:

$$\begin{aligned} \dot{e}(t) &= \dot{x}(t) - \dot{\hat{x}}(t) \\ &= \mathbf{A}x(t) + \mathbf{B}u(t) + w(t) - (\mathbf{A}\hat{x}(t) + \mathbf{B}u(t) + \mathbf{L}(t)(y(t) - \mathbf{C}\hat{x}(t))) \\ &= \mathbf{A}e(t) + w(t) - \mathbf{L}(t)(\mathbf{C}x(t) + v(t) - \mathbf{C}\hat{x}(t)) \\ &= (\mathbf{A} - \mathbf{L}(t)\mathbf{C})e(t) + w(t) - \mathbf{L}(t)v(t) \end{aligned} \quad (6.54)$$

Since $v(t)$ and $w(t)$ are zero mean white noise their weighted sum $n(t) = w(t) - \mathbf{L}(t)v(t)$ is also a zero mean white noise. We get:

$$n(t) = w(t) - \mathbf{L}(t)v(t) \Rightarrow \dot{e}(t) = (\mathbf{A} - \mathbf{L}(t)\mathbf{C})e(t) + n(t) \quad (6.55)$$

The covariance matrix \mathbf{Q}_N of $n(t)$ reads:

$$\begin{aligned} \mathbf{Q}_N &= E [n(t)n^T(t)] \\ &= E [(w(t) - \mathbf{L}(t)v(t))(w(t) - \mathbf{L}(t)v(t))^T] \\ &= \mathbf{P}_w + \mathbf{L}(t)\mathbf{Q}_v\mathbf{L}^T(t) \end{aligned} \quad (6.56)$$

Then the covariance matrix $\Pi(t)$ of $e(t)$ is obtained thanks to (6.14):

$$\begin{aligned} \dot{\Pi}(t) &= (\mathbf{A} - \mathbf{L}(t)\mathbf{C})\Pi(t) + \Pi(t)(\mathbf{A} - \mathbf{L}(t)\mathbf{C})^T + \mathbf{Q}_N \\ &= \mathbf{A}\Pi(t) + \Pi(t)\mathbf{A}^T - \mathbf{L}(t)\mathbf{C}\Pi(t) - \Pi(t)\mathbf{C}^T\mathbf{L}(t)^T + \mathbf{Q}_N \end{aligned} \quad (6.57)$$

By using the expression (6.56) of the covariance matrix \mathbf{Q}_N of $n(t)$ we get:

$$\begin{aligned} \dot{\Pi}(t) &= \mathbf{A}\Pi(t) + \Pi(t)\mathbf{A}^T + \mathbf{P}_w \\ &\quad - \mathbf{L}(t)\mathbf{C}\Pi(t) - \Pi(t)\mathbf{C}^T\mathbf{L}(t)^T + \mathbf{L}(t)\mathbf{Q}_v\mathbf{L}^T(t) \end{aligned} \quad (6.58)$$

Let's complete the square of $-\mathbf{L}(t)\mathbf{C}\Pi(t) - \Pi(t)\mathbf{C}^T\mathbf{L}(t)^T + \mathbf{L}(t)\mathbf{Q}_v\mathbf{L}^T(t)$. First we will focus on the scalar case where we try to minimize the following quadratic function $f(\mathbf{L})$ where $\mathbf{Q}_v > 0$:

$$f(\mathbf{L}) = -2\mathbf{L}\mathbf{C}\Pi + \mathbf{Q}_v\mathbf{L}^2 \quad (6.59)$$

Completing the square of $f(\mathbf{L})$ means writing $f(\mathbf{L})$ as follows:

$$f(\mathbf{L}) = \mathbf{Q}_v^{-1}(\mathbf{L}\mathbf{Q}_v - \Pi\mathbf{C})^2 - \Pi^2\mathbf{C}^2\mathbf{Q}_v^{-1} \quad (6.60)$$

Then it is clear that $f(\mathbf{L})$ is minimal when $\mathbf{L}\mathbf{Q}_v - \Pi\mathbf{C}$ and that the minimal value of $f(\mathbf{L})$ is $-\Pi^2\mathbf{C}^2\mathbf{Q}_v^{-1}$. This approach can be extended to the matrix case. When we complete the square of $-\mathbf{L}(t)\mathbf{C}\Pi(t) - \Pi(t)\mathbf{C}^T\mathbf{L}(t)^T + \mathbf{L}(t)\mathbf{Q}_v\mathbf{L}^T(t)$ we get:

$$\begin{aligned} -\mathbf{L}(t)\mathbf{C}\Pi(t) - \Pi(t)\mathbf{C}^T\mathbf{L}(t)^T + \mathbf{L}(t)\mathbf{Q}_v\mathbf{L}^T(t) &= \\ (\mathbf{L}(t)\mathbf{Q}_v - \Pi(t)\mathbf{C}^T)\mathbf{Q}_v^{-1}(\mathbf{L}(t)\mathbf{Q}_v - \Pi(t)\mathbf{C}^T)^T & \\ - \Pi(t)\mathbf{C}^T\mathbf{Q}_v^{-1}\mathbf{C}\Pi(t) & \end{aligned} \quad (6.61)$$

Using the preceding relationship within (6.58) reads:

$$\begin{aligned} \dot{\Pi}(t) &= \mathbf{A}\Pi(t) + \Pi(t)\mathbf{A}^T + \mathbf{P}_w \\ &\quad + (\mathbf{L}(t)\mathbf{Q}_v - \Pi(t)\mathbf{C}^T)\mathbf{Q}_v^{-1}(\mathbf{L}(t)\mathbf{Q}_v - \Pi(t)\mathbf{C}^T)^T \\ &\quad - \Pi(t)\mathbf{C}^T\mathbf{Q}_v^{-1}\mathbf{C}\Pi(t) \end{aligned} \quad (6.62)$$

In order to find the optimum observer gain $\mathbf{L}(t)$ which minimizes the covariance matrix $\Pi(t)$ we choose $\mathbf{L}(t)$ such that $\Pi(t)$ decreases by the maximum amount possible at each instant in time. This is accomplished by setting $\mathbf{L}(t)$ as follows:

$$\mathbf{L}(t)\mathbf{Q}_v - \Pi(t)\mathbf{C}^T = 0 \Leftrightarrow \mathbf{L}(t) = \Pi(t)\mathbf{C}^T\mathbf{Q}_v^{-1} \quad (6.63)$$

Once $\mathbf{L}(t)$ is set such that $\mathbf{L}(t)\mathbf{Q}_v - \Pi(t)\mathbf{C}^T = 0$ the matrix differential equation (6.62) reads as follows:

$$\dot{\Pi}(t) = \mathbf{A}\Pi(t) + \Pi(t)\mathbf{A}^T - \Pi(t)\mathbf{C}^T\mathbf{Q}_v^{-1}\mathbf{C}\Pi(t) + \mathbf{P}_w \quad (6.64)$$

This is Equation (6.51).

6.5 Duality principle

In the chapter dedicated to the closed-loop solution of the infinite horizon Linear Quadratic Regulator (LQR) problem we have seen that the minimization of the cost functional $J(u(t))$:

$$J(u(t)) = \frac{1}{2} \int_0^\infty x^T(t)\mathbf{Q}x(t) + u^T(t)\mathbf{R}u(t)dt \quad (6.65)$$

Under the constraint

$$\begin{cases} \frac{d}{dt}x(t) = \mathbf{A}x(t) + \mathbf{B}u(t) \\ x(0) = x_0 \end{cases} \quad (6.66)$$

This leads to solving the following algebraic Riccati equation where $\mathbf{Q} = \mathbf{Q}^T \geq 0$ (thus \mathbf{Q} is symmetric and positive semi-definite matrix), and $\mathbf{R} = \mathbf{R}^T > 0$ is a symmetric and positive definite matrix:

$$0 = \mathbf{P}\mathbf{A} + \mathbf{A}^T\mathbf{P} - \mathbf{P}\mathbf{B}\mathbf{R}^{-1}\mathbf{B}^T\mathbf{P} + \mathbf{Q} \quad (6.67)$$

The constant suboptimal Kalman gain \mathbf{K} and the suboptimal stabilizing control $u(t)$ are then defined as follows :

$$\begin{cases} u(t) = -\mathbf{K}x(t) \\ \mathbf{K} = \mathbf{R}^{-1}\mathbf{B}^T\mathbf{P} \end{cases} \quad (6.68)$$

Then let's compare the preceding relationships with the following relationships which are actually those which have been seen in (6.52):

$$\begin{cases} \mathbf{L} = \Pi\mathbf{C}^T\mathbf{Q}_v^{-1} \\ 0 = \Pi\mathbf{A}^T + \mathbf{A}\Pi - \Pi\mathbf{C}^T\mathbf{Q}_v^{-1}\mathbf{C}\Pi + \mathbf{P}_w \end{cases} \quad (6.69)$$

Then it is clear than the duality principle on Table 6.1 between observer and controller gains apply.

Controller	Observer
\mathbf{A}	\mathbf{A}^T
\mathbf{B}	\mathbf{C}^T
\mathbf{C}	\mathbf{B}^T
\mathbf{K}	\mathbf{L}^T
$\mathbf{P} = \mathbf{P}^T \geq 0$	$\Pi = \Pi^T \geq 0$
$\mathbf{Q} = \mathbf{Q}^T \geq 0$	$\mathbf{P}_w = \mathbf{P}_w^T \geq 0$
$\mathbf{R} = \mathbf{R}^T > 0$	$\mathbf{Q}_v = \mathbf{Q}_v^T > 0$
$\mathbf{A} - \mathbf{BK}$	$\mathbf{A}^T - \mathbf{C}^T\mathbf{L}^T$

Table 6.1: Duality principle

6.6 Controller transfer function

First let's assume that a full state feedback $u(t) = -\mathbf{K}x(t)$ is applied on the following system:

$$\begin{cases} \frac{d}{dt}x(t) = \mathbf{A}x(t) + \mathbf{B}u(t) + w(t) \\ y(t) = \mathbf{C}x(t) + v(t) \end{cases} \quad (6.70)$$

Then the dynamics of the closed-loop system is given by:

$$u(t) = -\mathbf{K}x(t) \Rightarrow \frac{d}{dt}x(t) = (\mathbf{A} - \mathbf{BK})x(t) + w(t) \quad (6.71)$$

If the full state vector $x(t)$ is assumed not to be available the control $u(t) = -\mathbf{K}x(t)$ cannot be computed. Then an observer has to be added. We recall the dynamics of the observer (see (6.9)):

$$\dot{\hat{x}}(t) = \mathbf{A}\hat{x}(t) + \mathbf{B}u(t) + \mathbf{L}(y(t) - \mathbf{C}\hat{x}(t)) \quad (6.72)$$

And the control $u(t) = -\mathbf{K}x(t)$ has to be changed into:

$$u(t) = -\mathbf{K}\hat{x}(t) \quad (6.73)$$

Gathering (6.72) and (6.73) leads to the state space representation of the controller:

$$\begin{bmatrix} \dot{\hat{x}}(t) \\ -u(t) \end{bmatrix} = \begin{bmatrix} \mathbf{A}_K & | & \mathbf{B}_K \\ \mathbf{C}_K & | & \mathbf{D}_K \end{bmatrix} \begin{bmatrix} \hat{x}(t) \\ y(t) \end{bmatrix} \quad (6.74)$$

Where:

$$\begin{bmatrix} \mathbf{A}_K & | & \mathbf{B}_K \\ \mathbf{C}_K & | & \mathbf{D}_K \end{bmatrix} = \begin{bmatrix} \mathbf{A} - \mathbf{BK} - \mathbf{LC} & | & \mathbf{L} \\ \mathbf{K} & | & 0 \end{bmatrix} \quad (6.75)$$

The controller transfer matrix $\mathbf{K}(s)$ is the relationship between the Laplace transform of its output, $U(s)$, and the Laplace transform of its input, $Y(s)$. By taking the Laplace transform of equation (6.72) and (6.73) (and assuming no initial condition) we get:

$$\begin{cases} s\hat{X}(s) = \mathbf{A}\hat{X}(s) + \mathbf{B}U(s) + \mathbf{L}(Y(s) - \mathbf{C}\hat{X}(s)) \\ U(s) = -\mathbf{K}\hat{X}(s) \end{cases} \quad (6.76)$$

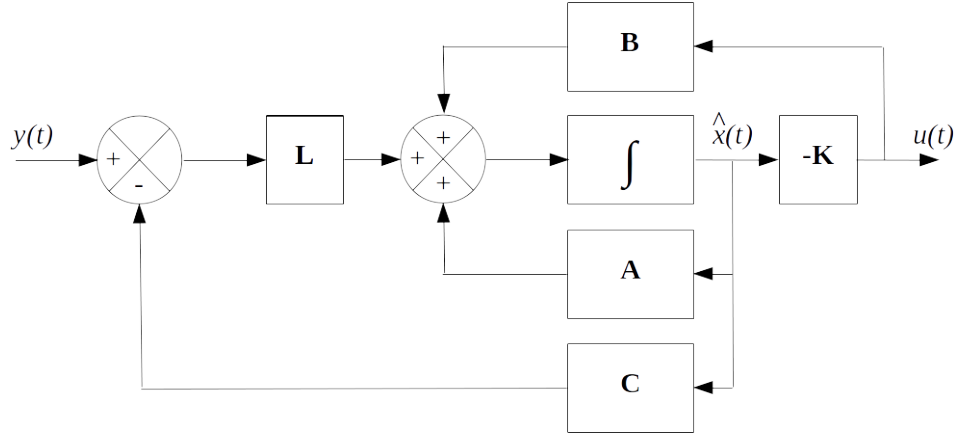

Figure 6.3: Block diagram of the controller

We finally get:

$$U(s) = -\mathbf{K}(s)Y(s) \quad (6.77)$$

where the controller transfer matrix $\mathbf{K}(s)$ reads:

$$\mathbf{K}(s) = \mathbf{K} (s\mathbb{I} - \mathbf{A} + \mathbf{BK} + \mathbf{LC})^{-1} \mathbf{L} \quad (6.78)$$

The preceding relationship can be equivalently represented by the block diagram on Figure 6.1.

6.7 Separation principle

Let $e(t)$ be the state estimation error:

$$e(t) = x(t) - \hat{x}(t) \quad (6.79)$$

Using (6.73) we get the following expressions for the dynamics of the state vector $x(t)$:

$$\begin{aligned} \dot{x}(t) &= \mathbf{A}x(t) + \mathbf{B}u(t) + w(t) \\ &= \mathbf{A}x(t) - \mathbf{BK}\hat{x}(t) + w(t) \\ &= \mathbf{A}x(t) - \mathbf{BK}(x(t) - e(t)) + w(t) \\ &= (\mathbf{A} - \mathbf{BK})x(t) + \mathbf{BK}e(t) + w(t) \end{aligned} \quad (6.80)$$

In addition using (6.72) and $y(t) = \mathbf{C}x(t) + v(t)$ we get the following expressions for the dynamics of the estimation error $e(t)$:

$$\begin{aligned} \dot{e}(t) &= \dot{x}(t) - \dot{\hat{x}}(t) \\ &= \mathbf{A}x(t) + \mathbf{B}u(t) + w(t) - (\mathbf{A}\hat{x}(t) + \mathbf{B}u(t) + \mathbf{L}(y(t) - \mathbf{C}\hat{x}(t))) \\ &= (\mathbf{A} - \mathbf{LC})e(t) + w(t) - \mathbf{L}v(t) \end{aligned} \quad (6.81)$$

Thus the closed-loop dynamics is defined as follows:

$$\begin{bmatrix} \dot{x}(t) \\ \dot{e}(t) \end{bmatrix} = \begin{bmatrix} \mathbf{A} - \mathbf{BK} & \mathbf{BK} \\ 0 & \mathbf{A} - \mathbf{LC} \end{bmatrix} \begin{bmatrix} x(t) \\ e(t) \end{bmatrix} + \begin{bmatrix} w(t) \\ w(t) - \mathbf{L}v(t) \end{bmatrix} \quad (6.82)$$

From equations (6.82) it is clear that the $2n$ eigenvalues of the closed-loop are just the union between the n eigenvalues of the state feedback coming from the spectrum of $\mathbf{A} - \mathbf{BK}$ and the n eigenvalues of the state estimator coming from the spectrum of $\mathbf{A} - \mathbf{LC}$. This result is called the separation principle. More precisely the separation principle states that the optimal control law is achieved by adopting the following two steps procedure:

- First assume an exact measurement of the full state to solve the deterministic Linear Quadratic (LQ) control problem which minimizes the following cost functional $J(u(t))$:

$$J(u(t)) = \frac{1}{2} \int_0^{\infty} x^T(t) \mathbf{Q} x(t) + u^T(t) \mathbf{R} u(t) dt \quad (6.83)$$

This leads to the following stabilizing control $u(t)$:

$$u(t) = -\mathbf{K}x(t) \quad (6.84)$$

Where the Kalman gain $\mathbf{K} = \mathbf{R}^{-1} \mathbf{B}^T \mathbf{P}$ is obtained thanks to the positive semi-definite solution \mathbf{P} of the following algebraic Riccati equation:

$$0 = \mathbf{P} \mathbf{A} + \mathbf{A}^T \mathbf{P} - \mathbf{P} \mathbf{B} \mathbf{R}^{-1} \mathbf{B}^T \mathbf{P} + \mathbf{Q} \quad (6.85)$$

- Then obtain an optimal estimate of the state which minimizes the following estimated error covariance:

$$E [e^T(t) e(t)] = E \left[(x(t) - \hat{x}(t))^T (x(t) - \hat{x}(t)) \right] \quad (6.86)$$

This leads to the Kalman-Bucy filter:

$$\frac{d}{dt} \hat{x}(t) = \mathbf{A} \hat{x}(t) + \mathbf{B} u(t) + \mathbf{L}(t) (y(t) - \mathbf{C} \hat{x}(t)) \quad (6.87)$$

And the stabilizing control $u(t)$ now reads:

$$u(t) = -\mathbf{K} \hat{x}(t) \quad (6.88)$$

The observer gain $\mathbf{L} = \mathbf{\Pi} \mathbf{C}^T \mathbf{Q}_v^{-1}$ is obtained thanks to the positive semi-definite solution $\mathbf{\Pi}$ of the following algebraic Riccati equation:

$$0 = \mathbf{A} \mathbf{\Pi} + \mathbf{\Pi} \mathbf{A}^T - \mathbf{\Pi} \mathbf{C}^T \mathbf{Q}_v^{-1} \mathbf{C} \mathbf{\Pi} + \mathbf{P}_w \quad (6.89)$$

It is worth noticing that observer dynamics must be faster than the desired state feedback dynamics.

Furthermore the dynamics of the state vector $x(t)$ is slightly modified when compared with an actual state feedback control $u(t) = -\mathbf{K}x(t)$. Indeed we have seen in (6.80) that the dynamics of the state vector $x(t)$ is now modified and depends on $e(t)$ and $w(t)$:

$$\dot{x}(t) = (\mathbf{A} - \mathbf{BK}) x(t) + \mathbf{BK} e(t) + w(t) \quad (6.90)$$

6.8 Loop Transfer Recovery

6.8.1 Lack of guaranteed robustness of LQG design

According to the choice of matrix \mathbf{L} which drives the dynamics of the error $e(t)$ the closed-loop may not be stable. So far LQR is shown to have either infinite gain margin (stable open-loop plant) or at least -6 dB gain margin and at least sixty degrees phase margin. In 1978 John Doyle¹ showed that all the nice robustness properties of LQR design can be lost once the observer is added and that LQG design can exhibit arbitrarily poor stability margins. Around 1981 Doyle along with Gunter Stein followed this line by showing that the loop shape itself will, in general, change when a filter is added for estimation. Fortunately there is a way of designing the Kalman-Bucy filter so that the full state feedback properties are recovered at the input of the plant. This is the purpose of the Loop Transfer Recovery design. The LQG/LTR design method was introduced by Doyle and Stein in 1981 before the development of H_2 and H_∞ methods which is a more general approach to directly handle many types of modelling uncertainties.

6.8.2 Doyle's seminal example

Consider the following state space realization:

$$\begin{cases} \begin{bmatrix} \dot{x}_1(t) \\ \dot{x}_2(t) \end{bmatrix} = \begin{bmatrix} 1 & 1 \\ 0 & 1 \end{bmatrix} \begin{bmatrix} x_1(t) \\ x_2(t) \end{bmatrix} + \begin{bmatrix} 0 \\ 1 \end{bmatrix} u(t) + \begin{bmatrix} 1 \\ 1 \end{bmatrix} w(t) \\ y(t) = \begin{bmatrix} 1 & 0 \end{bmatrix} \begin{bmatrix} x_1(t) \\ x_2(t) \end{bmatrix} + v(t) \end{cases} \quad (6.91)$$

where $w(t)$ and $v(t)$ are Gaussian white noise with covariance matrices \mathbf{P}_w and \mathbf{Q}_v , respectively:

$$\begin{cases} \mathbf{P}_w = \sigma \begin{bmatrix} 1 & 1 \\ 1 & 1 \end{bmatrix} \\ \sigma > 0 \\ \mathbf{Q}_v = 1 \end{cases} \quad (6.92)$$

Let $J(u(t))$ be the following cost functional to be minimized :

$$J(u(t)) = \frac{1}{2} \int_0^\infty x^T(t) \mathbf{Q} x(t) + u^T(t) \mathbf{R} u(t) dt \quad (6.93)$$

where:

$$\begin{cases} \mathbf{Q} = q \begin{bmatrix} 1 & 1 \\ 1 & 1 \end{bmatrix} \\ q > 0 \\ \mathbf{R} = 1 \end{cases} \quad (6.94)$$

Applying the separation principle the optimal control law is achieved by adopting the following two steps procedure:

¹Doyle J.C., Guaranteed margins for LQG regulators, IEEE Transactions on Automatic Control, Volume: 23, Issue: 4, Aug 1978

- First assume an exact measurement of the full state to solve the deterministic Linear Quadratic (LQ) control problem which minimizes the following cost functional $J(u(t))$:

$$J(u(t)) = \frac{1}{2} \int_0^{\infty} x^T(t) \mathbf{Q} x(t) + u^T(t) \mathbf{R} u(t) dt \quad (6.95)$$

This leads to the following stabilizing control $u(t)$:

$$u(t) = -\mathbf{K}x(t) \quad (6.96)$$

Where the Kalman gain $\mathbf{K} = \mathbf{R}^{-1} \mathbf{B}^T \mathbf{P}$ is obtained thanks to the positive semi-definite solution \mathbf{P} of the following algebraic Riccati equation:

$$0 = \mathbf{P} \mathbf{A} + \mathbf{A}^T \mathbf{P} - \mathbf{P} \mathbf{B} \mathbf{R}^{-1} \mathbf{B}^T \mathbf{P} + \mathbf{Q} \quad (6.97)$$

We get:

$$\mathbf{P} = \begin{bmatrix} \star & \star \\ \alpha & \alpha \end{bmatrix} \quad (6.98)$$

And:

$$\mathbf{K} = \mathbf{R}^{-1} \mathbf{B}^T \mathbf{P} = \alpha \begin{bmatrix} 1 & 1 \end{bmatrix} \text{ where } \alpha = 2 + \sqrt{4+q} > 0 \quad (6.99)$$

- Then obtain an optimal estimate of the state which minimizes the following estimated error covariance :

$$E [e^T(t) e(t)] = E \left[(x(t) - \hat{x}(t))^T (x(t) - \hat{x}(t)) \right] \quad (6.100)$$

This leads to the Kalman-Bucy filter:

$$\frac{d}{dt} \hat{x}(t) = \mathbf{A} \hat{x}(t) + \mathbf{B} u(t) + \mathbf{L}(t) (y(t) - \mathbf{C} \hat{x}(t)) \quad (6.101)$$

And the stabilizing control $u(t)$ now reads:

$$u(t) = -\mathbf{K} \hat{x}(t) \quad (6.102)$$

The observer gain $\mathbf{L} = \mathbf{\Pi} \mathbf{C}^T \mathbf{Q}_v^{-1}$ is obtained thanks to the positive semi-definite solution $\mathbf{\Pi}$ of the following algebraic Riccati equation:

$$0 = \mathbf{A} \mathbf{\Pi} + \mathbf{\Pi} \mathbf{A}^T - \mathbf{\Pi} \mathbf{C}^T \mathbf{Q}_v^{-1} \mathbf{C} \mathbf{\Pi} + \mathbf{P}_w \quad (6.103)$$

We get:

$$\mathbf{\Pi} = \begin{bmatrix} \beta & \star \\ \beta & \star \end{bmatrix} \quad (6.104)$$

And:

$$\mathbf{L} = \mathbf{\Pi} \mathbf{C}^T \mathbf{Q}_v^{-1} = \beta \begin{bmatrix} 1 \\ 1 \end{bmatrix} \text{ where } \beta = 2 + \sqrt{4+\sigma} > 0 \quad (6.105)$$

Now assume that the input matrix of the plant is multiplied by a scalar gain Δ (nominally unit) :

$$\dot{x}(t) = \mathbf{A}x(t) + \Delta\mathbf{B}u(t) + \begin{bmatrix} 1 \\ 1 \end{bmatrix} w(t) \quad (6.106)$$

In order to assess the stability of the closed-loop system we will assume no exogenous disturbance $v(t)$ and $w(t)$. Then the dynamics of the closed-loop system reads:

$$\begin{bmatrix} \dot{x}(t) \\ \dot{\hat{x}}(t) \end{bmatrix} = \mathbf{A}_{cl} \begin{bmatrix} x(t) \\ \hat{x}(t) \end{bmatrix} \quad (6.107)$$

Where:

$$\mathbf{A}_{cl} = \begin{bmatrix} \mathbf{A} & -\Delta\mathbf{BK} \\ \mathbf{LC} & \mathbf{A} - \mathbf{BK} - \mathbf{LC} \end{bmatrix} = \begin{bmatrix} 1 & 1 & 0 & 0 \\ 0 & 1 & -\Delta\alpha & -\Delta\alpha \\ \beta & 0 & 1 - \beta & 1 \\ \beta & 0 & -\alpha - \beta & 1 - \alpha \end{bmatrix} \quad (6.108)$$

The characteristic equation of the closed-loop system is:

$$\det(s\mathbb{I} - \mathbf{A}_{cl}) = s^4 + p_3s^3 + p_2s^2 + p_1s + p_0 = 0 \quad (6.109)$$

The evaluation of coefficients p_3 , p_2 , p_1 and p_0 is quite tedious. Nevertheless coefficient p_0 reads;

$$p_0 = 1 + (1 - \Delta)\alpha\beta \quad (6.110)$$

The closed-loop system is unstable if:

$$p_0 < 0 \Leftrightarrow \Delta > 1 + \frac{1}{\alpha\beta} \quad (6.111)$$

With large values of α and β even a slight increase in the value of Δ from its nominal value will render the closed-loop system to be unstable. Thus the phase margin of the LQG control-loop can be almost 0. This example clearly shows that the robustness of the LQG control-loop to modelling uncertainty is not guaranteed.

6.8.3 Loop Transfer Recovery (LTR) design

Linear Quadratic (LQ) controller and the Kalman-Bucy filter (KF) alone have very good robustness property. Nevertheless we have seen with Doyle's seminal example that Linear Quadratic Gaussian (LQG) control which simultaneously involves a Linear Quadratic (LQ) controller and a Kalman-Bucy filter (KF) does not have any guaranteed robustness. Therefore the LQG / LTR design tries to recover a target open-loop transfer function. The target loop transfer function is either:

- the Linear Quadratic (LQ) control open-loop transfer function, which is $\mathbf{K}\Phi(s)\mathbf{B}$
- or the Kalman-Bucy filter (KF) open-loop transfer function, which is $\mathbf{C}\Phi(s)\mathbf{L}$.

Let ρ be a parameter design of either design matrix \mathbf{Q} or matrix \mathbf{P}_w and $G(s)$ the transfer function of the plant:

$$G(s) = \mathbf{C}\Phi(s)\mathbf{B} \quad (6.112)$$

Then two types of Loop Transfer Recovery are possible:

- Input recovery: the objective is to tune ρ such that:

$$\lim_{\rho \rightarrow \infty} \mathbf{K}(s)G(s) = \mathbf{K}\Phi(s)\mathbf{B} \quad (6.113)$$

- Output recovery: the objective is to tune ρ such that:

$$\lim_{\rho \rightarrow \infty} G(s)\mathbf{K}(s) = \mathbf{C}\Phi(s)\mathbf{L} \quad (6.114)$$

We recall that initial design matrices \mathbf{Q}_0 and \mathbf{R}_0 are set to meet control requirements whereas initial design matrices \mathbf{P}_{w0} and \mathbf{Q}_{v0} are set to meet observer requirements. Let ρ be a parameter design of either design matrix \mathbf{P}_w or matrix \mathbf{Q} . Weighting parameter ρ is tuned to make a trade-off between initial performances and stability margins and is set according to the type of Loop Transfer Recovery:

- Input recovery: a new observer design with the following design matrices:

$$\begin{cases} \mathbf{P}_w = \mathbf{P}_{w0} + \rho^2 \mathbf{B}\mathbf{B}^T \\ \mathbf{Q}_v = \mathbf{P}_{v0} \end{cases} \quad (6.115)$$

- Output recovery: a new controller is designed with the following design matrices:

$$\begin{cases} \mathbf{Q} = \mathbf{Q}_0 + \rho^2 \mathbf{C}^T \mathbf{C} \\ \mathbf{R} = \mathbf{R}_0 \end{cases} \quad (6.116)$$

The preceding relationship is simply obtained by applying the duality principle.

To apply Loop Transfer Recovery the transfer matrix $\mathbf{C}\Phi(s)\mathbf{B}$ shall be minimum phase (i.e. no zero with positive real part) and square (meaning that the system has the same number of inputs and outputs).

Example 6.2. *Let's the double integrator plant:*

$$\begin{cases} \mathbf{A} = \begin{bmatrix} 0 & 1 \\ 0 & 0 \end{bmatrix} \\ \mathbf{B} = \begin{bmatrix} 0 \\ 1 \end{bmatrix} \\ \mathbf{C} = \begin{bmatrix} 1 & 0 \end{bmatrix} \end{cases} \quad (6.117)$$

Let:

$$\begin{cases} \mathbf{K} = \begin{bmatrix} k_1 & k_2 \end{bmatrix} \\ \mathbf{L} = \begin{bmatrix} l_1 \\ l_2 \end{bmatrix} \end{cases} \quad (6.118)$$

Then the controller transfer matrix is given by (6.78):

$$\begin{aligned}\mathbf{K}(s) &= \mathbf{K}(s\mathbb{I} - \mathbf{A} + \mathbf{BK} + \mathbf{LC})^{-1} \mathbf{L} \\ &= \begin{bmatrix} k_1 & k_2 \end{bmatrix} \begin{bmatrix} s + l_1 & -1 \\ k_1 + l_2 & s + k_2 \end{bmatrix}^{-1} \begin{bmatrix} l_1 \\ l_2 \end{bmatrix} \\ &= \frac{(k_1 l_1 + k_2 l_2)s + k_1 l_2}{s^2 + (k_2 + l_1)s + k_2 l_1 + k_1 + l_2}\end{aligned}\quad (6.119)$$

From (6.116) we set \mathbf{Q} and \mathbf{R} as follows:

$$\begin{cases} \mathbf{Q}_0 = 0 \\ \mathbf{Q} = \mathbf{Q}_0 + \rho^2 \mathbf{C}^T \mathbf{C} \Rightarrow \mathbf{Q} = \rho^2 \mathbf{C}^T \mathbf{C} \\ \mathbf{R} = \mathbf{R}_0 = 1 \end{cases}\quad (6.120)$$

The Kalman gain $\mathbf{K} = \mathbf{R}^{-1} \mathbf{B}^T \mathbf{P}$ is then obtained thanks to the positive semi-definite solution \mathbf{P} of the following algebraic Riccati equation:

$$\begin{aligned}0 &= \mathbf{P}\mathbf{A} + \mathbf{A}^T \mathbf{P} - \mathbf{P}\mathbf{B}\mathbf{R}^{-1} \mathbf{B}^T \mathbf{P} + \mathbf{Q} \Rightarrow \mathbf{P} = \begin{bmatrix} \star & \star \\ \rho & \sqrt{2\rho} \end{bmatrix} \\ \Rightarrow \mathbf{K} &= \mathbf{R}^{-1} \mathbf{B}^T \mathbf{P} = \begin{bmatrix} \rho & \sqrt{2\rho} \end{bmatrix} \equiv \begin{bmatrix} k_1 & k_2 \end{bmatrix}\end{aligned}\quad (6.121)$$

Consequently:

$$\begin{aligned}\lim_{\rho \rightarrow \infty} \mathbf{K}(s) &= \lim_{\rho \rightarrow \infty} \frac{(k_1 l_1 + k_2 l_2)s + k_1 l_2}{s^2 + (k_2 + l_1)s + k_2 l_1 + k_1 + l_2} \\ &= \frac{k_1 l_1 s + k_1 l_2}{k_1} \\ &= l_1 s + l_2\end{aligned}\quad (6.122)$$

The transfer function of the plant reads:

$$G(s) = \mathbf{C}\Phi(s)\mathbf{B} = \mathbf{C}(s\mathbb{I} - \mathbf{A})^{-1} \mathbf{B} = \frac{1}{s^2}\quad (6.123)$$

Therefore:

$$\lim_{\rho \rightarrow \infty} \mathbf{K}(s)G(s) = \text{frac}l_1 s + l_2 s^2\quad (6.124)$$

Note that:

$$\mathbf{C}\Phi(s)\mathbf{L} = \text{frac}l_1 s + l_2 s^2\quad (6.125)$$

Therefore the loop transfer function has been recovered. ■

6.9 Proof of the Loop Transfer Recovery condition

6.9.1 Loop transfer function with observer

The Loop Transfer Recovery design procedure tries to recover a target loop transfer function, here the open-loop full state LQ control, despite the use of the observer.

The lecture of Faryar Jabbari, from the Henry Samueli School of Engineering, University of California, is the primary source of this section ². We will first

²<http://gram.eng.uci.edu/~fjabbari/me270b/chap9.pdf>

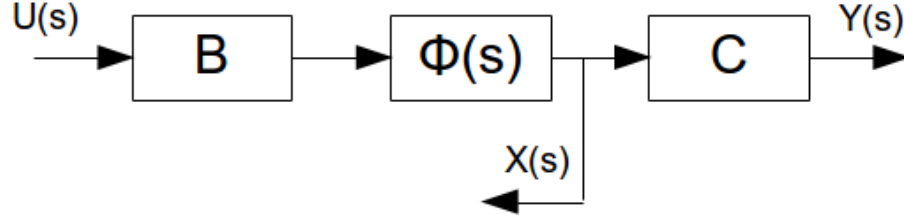

Figure 6.4: Block diagram for state space realization

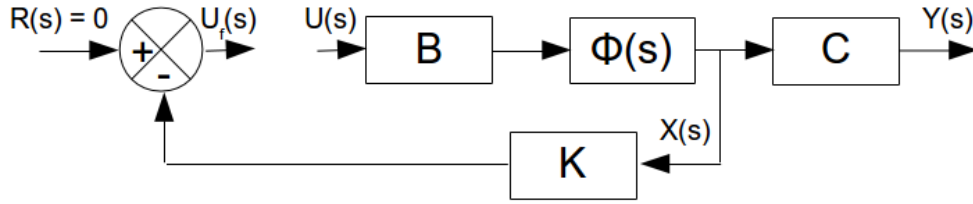

Figure 6.5: Loop transfer function with full state feedback evaluated when the loop is broken

show what happen when adding an observer-based closed-loop on the following system where $y(t)$ is the *actual* output of the system (not the *controlled* output):

$$\begin{cases} \dot{x}(t) = \mathbf{A}x(t) + \mathbf{B}u(t) \\ y(t) = \mathbf{C}x(t) \end{cases} \quad (6.126)$$

Taking the Laplace transform (assuming initial conditions to be zero), we get:

$$\begin{cases} sX(s) = \mathbf{A}X(s) + \mathbf{B}U(s) \\ Y(s) = \mathbf{C}X(s) \end{cases} \Rightarrow \begin{cases} X(s) = \Phi(s)\mathbf{B}U(s) \\ Y(s) = \mathbf{C}X(s) \end{cases} \quad (6.127)$$

Where:

$$\Phi(s) = (s\mathbf{I} - \mathbf{A})^{-1} \quad (6.128)$$

The preceding relationships can be represented by the block diagram on Figure 6.4. Let \mathbf{K} be a full state feedback gain matrix such that the closed-loop system is asymptotically stable, i.e. the eigenvalues of $\mathbf{A} - \mathbf{B}\mathbf{K}$ lie in the left half s -plane, and the open-loop transfer function when the loop is broken at the input point of the given system meets some given frequency dependent specifications. The state feedback control u_f with full state available is:

$$u_f(t) = -\mathbf{K}x(t) \Leftrightarrow U_f(s) = -\mathbf{K}X(s) \quad (6.129)$$

We will focus on the regulator problem and thus $r = 0$. As shown in Figure 6.5 the loop transfer function is evaluated when the loop is broken at the input point of the system. The so called target loop transfer function $\mathbf{L}_t(s)$ is:

$$U_f(s) = \mathbf{L}_t(s)U(s) \quad \text{where } \mathbf{L}_t = -\mathbf{K}\Phi(s)\mathbf{B} \quad (6.130)$$

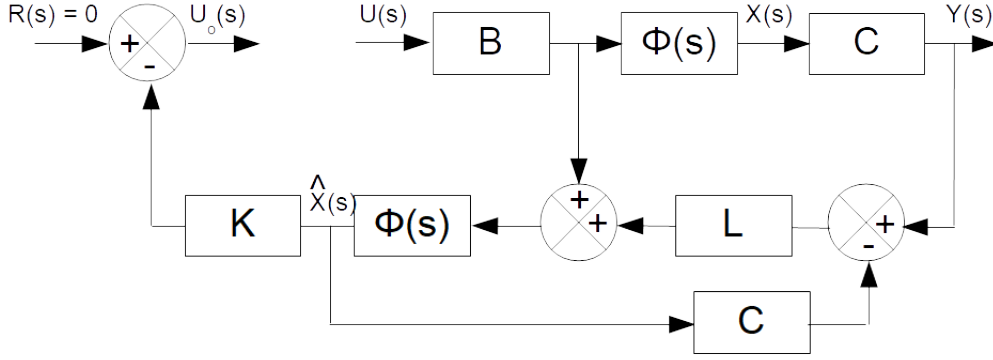

Figure 6.6: Loop transfer function with observer evaluated when the loop is broken

If the full state vector $x(t)$ is assumed not to be available, the control $u(t) = -\mathbf{K}x(t)$ cannot be computed. We then add an observer with the following expression:

$$\dot{\hat{x}}(t) = \mathbf{A}\hat{x}(t) + \mathbf{B}u(t) + \mathbf{L}(y(t) - \mathbf{C}\hat{x}(t)) \quad (6.131)$$

The observed state feedback control u_o is:

$$u_o(t) = -\mathbf{K}\hat{x}(t) \quad (6.132)$$

Taking the Laplace transform would result in:

$$\begin{cases} s\hat{X}(s) = \mathbf{A}\hat{X}(s) + \mathbf{B}U(s) + \mathbf{L}(Y(s) - \mathbf{C}\hat{X}(s)) \\ U_o(s) = -\mathbf{K}\hat{X}(s) \end{cases} \quad (6.133)$$

The preceding relationships can be represented by the block diagram on Figure 6.6. Then loop transfer function evaluated when the loop is broken at the input point of the given system becomes:

$$\begin{aligned} & \begin{cases} \hat{X}(s) = (\Phi(s)^{-1} + \mathbf{LC})^{-1}(\mathbf{B}U(s) + \mathbf{L}Y(s)) \\ Y(s) = \mathbf{C}\Phi(s)\mathbf{B}U(s) \end{cases} \\ & \Rightarrow \hat{X}(s) = (\Phi(s)^{-1} + \mathbf{LC})^{-1}(\mathbf{B}U(s) + \mathbf{LC}\Phi(s)\mathbf{B}U(s)) \\ & \Leftrightarrow \hat{X}(s) = (\Phi(s)^{-1} + \mathbf{LC})^{-1}(\mathbf{B} + \mathbf{LC}\Phi(s)\mathbf{B})U(s) \\ & \Leftrightarrow \hat{X}(s) = (\Phi(s)^{-1} + \mathbf{LC})^{-1}\mathbf{B}U(s) + (\Phi(s)^{-1} + \mathbf{LC})^{-1}\mathbf{LC}\Phi(s)\mathbf{B}U(s) \end{aligned} \quad (6.134)$$

Note that according to the choice of the observer matrix \mathbf{L} the controller may not be stable. In addition, equation (6.133), in general, is not the same as (6.129).

The Loop Transfer Recovery condition indicates that if the following relationship holds then we get for $U_o(s)$ the same expression as the full state feedback $U_f(s)$:

$$\mathbf{L}(\mathbb{I} + \mathbf{C}\Phi(s)\mathbf{L})^{-1} = \mathbf{B}(\mathbf{C}\Phi(s)\mathbf{B})^{-1} \quad (6.135)$$

6.9.2 Application of matrix inversion lemma to LTR

The matrix inversion lemma ³ is the equation:

$$(\mathbf{A} - \mathbf{B}\mathbf{D}^{-1}\mathbf{C})^{-1} = \mathbf{A}^{-1} + \mathbf{A}^{-1}\mathbf{B}(\mathbf{D} - \mathbf{C}\mathbf{A}^{-1}\mathbf{B})^{-1}\mathbf{C}\mathbf{A}^{-1} \quad (6.136)$$

Simple manipulations show that:

$$(\Phi(s)^{-1} + \mathbf{L}\mathbf{C})^{-1} = \Phi(s) \left(\mathbb{I} - \mathbf{L}(\mathbb{I} + \mathbf{C}\Phi(s)\mathbf{L})^{-1}\mathbf{C}\Phi(s) \right) \quad (6.137)$$

So we have for the first term to the right of equation (6.134):

$$(\Phi(s)^{-1} + \mathbf{L}\mathbf{C})^{-1}\mathbf{B} = \Phi(s) \left(\mathbb{I} - \mathbf{L}(\mathbb{I} + \mathbf{C}\Phi(s)\mathbf{L})^{-1}\mathbf{C}\Phi(s)\mathbf{B} \right) \quad (6.138)$$

And for the second term to the right of equation (6.134):

$$\begin{aligned} (\Phi(s)^{-1} + \mathbf{L}\mathbf{C})^{-1}\mathbf{L}\mathbf{C}\Phi(s)\mathbf{B} &= \Phi(s) \left(\mathbb{I} - \mathbf{L}(\mathbb{I} + \mathbf{C}\Phi(s)\mathbf{L})^{-1}\mathbf{C}\Phi(s) \right) \mathbf{L}\mathbf{C}\Phi(s)\mathbf{B} \\ &= \Phi(s) \left(\mathbf{L} - \mathbf{L}(\mathbb{I} + \mathbf{C}\Phi(s)\mathbf{L})^{-1}\mathbf{C}\Phi(s)\mathbf{L} \right) \mathbf{C}\Phi(s)\mathbf{B} \\ &= \Phi(s)\mathbf{L} \left(\mathbb{I} - (\mathbb{I} + \mathbf{C}\Phi(s)\mathbf{L})^{-1}\mathbf{C}\Phi(s)\mathbf{L} \right) \mathbf{C}\Phi(s)\mathbf{B} \end{aligned} \quad (6.139)$$

In addition, applying again the matrix inversion lemma to the following equality, we have:

$$\begin{aligned} (\mathbb{I} + \mathbf{A})^{-1} &= \mathbb{I} - (\mathbb{I} + \mathbf{A})^{-1}\mathbf{A} \\ \Rightarrow (\mathbb{I} + \mathbf{A})^{-1}\mathbf{A} &= \mathbb{I} - (\mathbb{I} + \mathbf{A})^{-1} \end{aligned} \quad (6.140)$$

Thus

$$(\mathbb{I} + \mathbf{C}\Phi(s)\mathbf{L})^{-1}\mathbf{C}\Phi(s)\mathbf{L} = \mathbb{I} - (\mathbb{I} + \mathbf{C}\Phi(s)\mathbf{L})^{-1} \quad (6.141)$$

Applying this result to equation (6.139) leads to:

$$(\Phi(s)^{-1} + \mathbf{L}\mathbf{C})^{-1}\mathbf{L}\mathbf{C}\Phi(s)\mathbf{B} = \Phi(s)\mathbf{L}(\mathbb{I} + \mathbf{C}\Phi(s)\mathbf{L})^{-1}\mathbf{C}\Phi(s)\mathbf{B} \quad (6.142)$$

And here comes the light! Indeed, if we had:

$$\mathbf{L}(\mathbb{I} + \mathbf{C}\Phi(s)\mathbf{L})^{-1} = \mathbf{B}(\mathbf{C}\Phi(s)\mathbf{B})^{-1} \quad (6.143)$$

Then equations (6.142) and (6.138) become:

$$\begin{cases} (\Phi(s)^{-1} + \mathbf{L}\mathbf{C})^{-1}\mathbf{L}\mathbf{C}\Phi(s)\mathbf{B} = \Phi(s)\mathbf{L}(\mathbb{I} + \mathbf{C}\Phi(s)\mathbf{L})^{-1}\mathbf{C}\Phi(s)\mathbf{B} = \Phi(s)\mathbf{B} \\ (\Phi(s)^{-1} + \mathbf{L}\mathbf{C})^{-1}\mathbf{B} = \Phi(s) \left(\mathbb{I} - \mathbf{L}(\mathbb{I} + \mathbf{C}\Phi(s)\mathbf{L})^{-1}\mathbf{C}\Phi(s)\mathbf{B} \right) = \Phi(s)(\mathbb{I} - \mathbf{B}) \end{cases} \quad (6.144)$$

And thus:

$$\hat{X}(s) = \Phi(s)\mathbf{B}U(s) \Rightarrow U_o(s) = -\mathbf{K}\hat{X}(s) = -\mathbf{K}\Phi(s)\mathbf{B}U(s) \quad (6.145)$$

That is, we get for $U_o(s)$ the same expression as the full state feedback given in (6.129).

³D. J. Tylavsky, G. R. L. Sohie, Generalization of the matrix inversion lemma, Proceedings of the IEEE, Year: 1986, Volume: 74, Issue: 7, Pages: 1050 - 1052

6.9.3 Setting the Loop Transfer Recovery design parameter

Condition (6.135) is not an easy condition to satisfy. The traditional approaches to this problem is to design matrix \mathbf{L} of the observer such that the condition is satisfied asymptotically and ρ a design parameter.

One way to asymptotically satisfy (6.135) is to set \mathbf{L} such that:

$$\lim_{\rho \rightarrow \infty} \frac{\mathbf{L}}{\rho} = \mathbf{B}W_0 \quad (6.146)$$

where W_0 is a non singular matrix.

Indeed in this case we have:

$$\begin{aligned} \mathbf{L}(\mathbb{I} + \mathbf{C}\Phi(s)\mathbf{L})^{-1} &= \frac{\mathbf{L}}{\rho}\rho(\mathbb{I} + \mathbf{C}\Phi(s)\mathbf{L})^{-1} \\ &= \frac{\mathbf{L}}{\rho} \left(\frac{1}{\rho}\mathbb{I} + \mathbf{C}\Phi(s)\frac{\mathbf{L}}{\rho} \right)^{-1} \end{aligned} \quad (6.147)$$

and as $\rho \rightarrow \infty$:

$$\begin{aligned} \lim_{\rho \rightarrow \infty} \mathbf{L}(\mathbb{I} + \mathbf{C}\Phi(s)\mathbf{L})^{-1} &= \lim_{\rho \rightarrow \infty} \frac{\mathbf{L}}{\rho} \left(\frac{1}{\rho}\mathbb{I} + \mathbf{C}\Phi(s)\frac{\mathbf{L}}{\rho} \right)^{-1} \\ &= \mathbf{B}W_0(\mathbf{C}\Phi(s)\mathbf{B}W_0)^{-1} \\ &= \mathbf{B}(\mathbf{C}\Phi(s)\mathbf{B})^{-1} \end{aligned} \quad (6.148)$$

Now let's concentrate how (6.146) can be achieved. First it can be shown that if the transfer function $\mathbf{C}\Phi(s)\mathbf{B}$ is right invertible with no unstable zeros then for some unitary matrix W ($WW^T = \mathbb{I}$) and some symmetric positive definite matrix N ($N = N^T > 0$) the following relationship holds:

$$\begin{cases} \mathbf{R} = \rho^2 N \\ \mathbf{Q} = \mathbf{C}^T \mathbf{C} \\ \mathbf{K} = \mathbf{R}^{-1} \mathbf{B}^T \mathbf{P} \end{cases} \Rightarrow \lim_{\rho \rightarrow \infty} \mathbf{K} = \mathbf{R}^{-0.5} W \mathbf{C} = \frac{1}{\rho} N^{-0.5} W \mathbf{C} \quad (6.149)$$

Applying the duality principle we have the same result for the observer gain \mathbf{L} :

$$\begin{cases} \mathbf{Q}_v = \rho^2 N \\ \mathbf{P}_w = \mathbf{B} \mathbf{B}^T \\ \mathbf{L} = \mathbf{\Pi} \mathbf{C}^T \mathbf{Q}_v^{-1} \end{cases} \Rightarrow \lim_{\rho \rightarrow \infty} \mathbf{L} = \mathbf{B} W \mathbf{Q}_v^{-0.5} = \frac{1}{\rho} \mathbf{B} W N^{-0.5} \quad (6.150)$$

Then if we replace $\mathbf{P}_w = \mathbf{B} \mathbf{B}^T$ by $\mathbf{P}_w = \mathbf{P}_{w0} + \rho^2 \mathbf{B} \mathbf{B}^T$ and \mathbf{Q}_v by \mathbf{P}_{v0} we get:

$$\begin{cases} \mathbf{P}_w = \mathbf{P}_{w0} + \rho^2 \mathbf{B} \mathbf{B}^T \\ \mathbf{Q}_v = \mathbf{P}_{v0} \end{cases} \Rightarrow \lim_{\rho \rightarrow \infty} \mathbf{L} = \rho \mathbf{B} W \mathbf{P}_{v0}^{-0.5} \Leftrightarrow \lim_{\rho \rightarrow \infty} \frac{\mathbf{L}}{\rho} = \mathbf{B} W \mathbf{P}_{v0}^{-0.5} \quad (6.151)$$

By setting $W_0 = W \mathbf{P}_{v0}^{-0.5}$ we finally get (6.146):

$$\lim_{\rho \rightarrow \infty} \frac{\mathbf{L}}{\rho} = \mathbf{B}W_0 \quad (6.152)$$

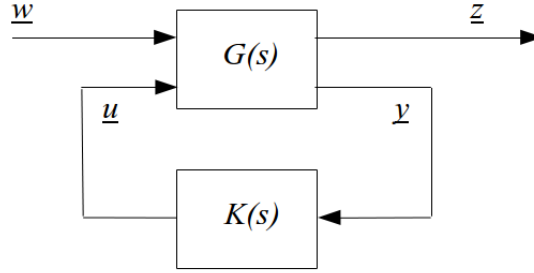

Figure 6.7: Standard feedback control loop

6.10 H_2 robust control design

Robust control problems are solved in a dedicated framework presented on Figure 6.7 where:

- $\mathbf{G}(s)$ is the transfer matrix of the *generalized* plant;
- $\mathbf{K}(s)$ is the transfer matrix of the controller ;
- \underline{u} is the control vector of the *generalized* plant $\mathbf{G}(s)$ which is computed by the controller $\mathbf{K}(s)$;
- \underline{w} is the input vector formed by *exogenous inputs* such as disturbances or noise;
- \underline{y} is the vector of output available for the controller $\mathbf{K}(s)$;
- \underline{z} is the performance output vector, also called the *controlled* output, that is the vector that allows to characterize the performance of the closed-loop system. This is a *virtual* output used only for design that we wish to maintain as small as possible.

It is worth noticing that in the standard feedback control loop on Figure 6.7 *all reference signals are set to zero*.

The H_2 control problem consists in finding the optimal controller $\mathbf{K}(s)$ which minimizes $\|\mathbf{T}_{zw}(s)\|_2$, that is the H_2 norm of the transfer between the exogenous inputs vector \underline{w} and the vector of interest variables \underline{z} .

The general form of the realization of a plant is the following:

$$\begin{bmatrix} \dot{\underline{x}}(t) \\ \underline{z}(t) \\ \underline{y}(t) \end{bmatrix} = \begin{bmatrix} \mathbf{A} & \mathbf{B}_1 & \mathbf{B}_2 \\ \mathbf{C}_1 & \mathbf{0} & \mathbf{D}_{12} \\ \mathbf{C}_2 & \mathbf{D}_{21} & \mathbf{0} \end{bmatrix} \begin{bmatrix} \underline{x}(t) \\ \underline{w}(t) \\ \underline{u}(t) \end{bmatrix} \quad (6.153)$$

Linear-quadratic-Gaussian (LQG) control is a special case of H_2 optimal control applied to stochastic system.

Let's consider the following system realization:

$$\begin{cases} \dot{\underline{x}}(t) = \mathbf{A}\underline{x}(t) + \mathbf{B}_2\underline{u}(t) + \underline{d}(t) \\ \underline{y}(t) = \mathbf{C}_2\underline{x}(t) + \underline{n}(t) \end{cases} \quad (6.154)$$

Where $\underline{d}(t)$ and $\underline{n}(t)$ are white noise with the intensity of their autocorrelation function equals to \mathbf{W}_d and \mathbf{W}_n respectively. Denoting by $E()$ the mathematical expectation we have:

$$E \left(\begin{bmatrix} \underline{d}(t) \\ \underline{n}(t) \end{bmatrix} \begin{bmatrix} \underline{d}^T(\tau) & \underline{n}^T(\tau) \end{bmatrix} \right) = \begin{bmatrix} \mathbf{W}_d & \mathbf{0} \\ \mathbf{0} & \mathbf{W}_n \end{bmatrix} \delta(t - \tau) \quad (6.155)$$

The LQG problem consists in finding a controller $\underline{u}(s) = \mathbf{K}(s)\underline{y}(s)$ such that the following performance index is minimized:

$$J_{LQG} = E \left(\lim_{T \rightarrow \infty} \int_0^T (\underline{x}^T(t)\mathbf{Q}\underline{x}(t) + \underline{u}^T(t)\mathbf{R}\underline{u}(t)) dt \right) \quad (6.156)$$

Where matrices \mathbf{Q} and \mathbf{R} are symmetric and (semi)-positive definite matrices:

$$\begin{cases} \mathbf{Q} = \mathbf{Q}^T \geq \mathbf{0} \\ \mathbf{R} = \mathbf{R}^T > \mathbf{0} \end{cases} \quad (6.157)$$

This problem can be cast as the H_2 optimal control framework in the following manner. Define signal $\underline{z}(t)$ whose norm is to be minimized as follows:

$$\underline{z}(t) = \begin{bmatrix} \mathbf{Q}^{0.5} & \mathbf{0} \\ \mathbf{0} & \mathbf{R}^{0.5} \end{bmatrix} \begin{bmatrix} \underline{x}(t) \\ \underline{u}(t) \end{bmatrix} \quad (6.158)$$

And represent the stochastic inputs $\underline{d}(t)$ and $\underline{n}(t)$ as a function of the vector $\underline{w}(t)$ of exogenous disturbances :

$$\begin{bmatrix} \underline{d}(t) \\ \underline{n}(t) \end{bmatrix} = \begin{bmatrix} \mathbf{W}_d^{0.5} & \mathbf{0} \\ \mathbf{0} & \mathbf{W}_n^{0.5} \end{bmatrix} \underline{w}(t) \quad (6.159)$$

Where $\underline{w}(t)$ is a white noise process of unit intensity. Then the LQG cost function reads as follows:

$$J_{LQG} = E \left(\lim_{T \rightarrow \infty} \int_0^T \underline{z}^T(t)\underline{z}(t)dt \right) = \|\mathbf{T}_{zw}(s)\|_2^2 \quad (6.160)$$

And the generalised plant reads as follows:

$$\begin{bmatrix} \dot{\underline{x}}(t) \\ \underline{z}(t) \\ \underline{y}(t) \end{bmatrix} = \begin{bmatrix} \mathbf{A} & \mathbf{B}_1 & \mathbf{B}_2 \\ \mathbf{C}_1 & \mathbf{0} & \mathbf{D}_{12} \\ \mathbf{C}_2 & \mathbf{D}_{21} & \mathbf{0} \end{bmatrix} \begin{bmatrix} \underline{x}(t) \\ \underline{w}(t) \\ \underline{u}(t) \end{bmatrix} \quad (6.161)$$

Where:

$$\begin{cases} \mathbf{B}_1 = [\mathbf{W}_d^{0.5} & \mathbf{0}] \\ \mathbf{C}_1 = \begin{bmatrix} \mathbf{Q}^{0.5} \\ \mathbf{0} \end{bmatrix} \\ \mathbf{D}_{12} = \begin{bmatrix} \mathbf{0} \\ \mathbf{R}^{0.5} \end{bmatrix} \\ \mathbf{D}_{21} = [\mathbf{0} & \mathbf{W}_n^{0.5}] \end{cases} \quad (6.162)$$

It follows that:

$$\begin{cases} \mathbf{B}_1 \underline{w}(t) = [\mathbf{W}_d^{0.5} & \mathbf{0}] \underline{w}(t) = \underline{d}(t) \\ \mathbf{D}_{21} \underline{w}(t) = [\mathbf{0} & \mathbf{W}_n^{0.5}] \underline{w}(t) = \underline{n}(t) \end{cases} \quad (6.163)$$

And:

$$\begin{aligned} \underline{z}^T(t) \underline{z}(t) &= (\mathbf{C}_1 \underline{x}(t) + \mathbf{D}_{12} \underline{w}(t))^T (\mathbf{C}_1 \underline{x}(t) + \mathbf{D}_{12} \underline{w}(t)) \\ &= \underline{x}^T(t) \mathbf{Q} \underline{x}(t) + \underline{u}^T(t) \mathbf{R} \underline{u}(t) \end{aligned} \quad (6.164)$$

Thus costs (6.156) and (6.160) are equivalent.